

1.0 Amp

- Non Isolated 1.0A Switching Regulator
- Regulated Single Outputs from 3.3 to 15VDC
- Wide Input Range to 36V
- SIP3 Package
- High Efficiency to 96%
- Class B Conducted & Radiated Emissions
- Short Circuit Protection
- Low 0.3mA Standby Input Current
- -40°C to +85°C Operation
- MTBF >2Mhrs
- 3 Year Warranty

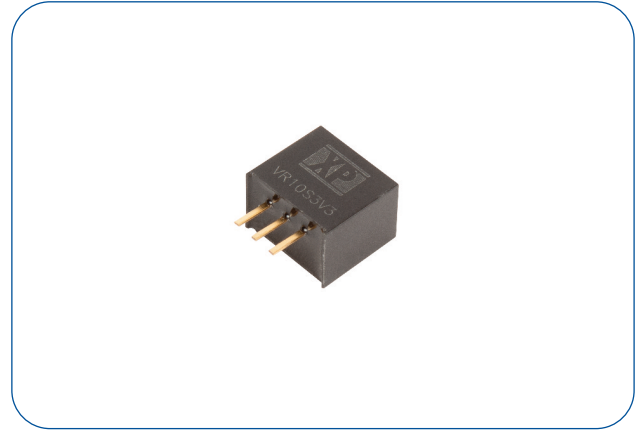

Dimensions:

VR10:
0.457 x 0.409 x 0.315" (11.6 x 10.4 x 8.0mm)

The VR10 provides a cost effective compact efficient switching regulator solution operating from a wide range DC input. Output voltages start from 3.3V and the VR10 consumes as little as 0.3mA when idle.

Models & Ratings

Input Voltage	Output Voltage	Output Current	Input Current ⁽¹⁾		Max. Capacitive Load	Efficiency ⁽²⁾		Model Number
			No Load	Full Load		Vin, Min.	Vin, Max.	
6-36V	3.3V	1.0A	1.0mA	660mA	680µF	90%	80%	VR10S3V3
8-36V	5.0V	1.0A	0.3mA	720mA	680µF	93%	85%	VR10S05
10-36V	6.5V	1.0A	0.3mA	740mA	680µF	93%	85%	VR10S6V5
13-36V	9.0V	1.0A	0.3mA	760mA	680µF	94%	89%	VR10S09
16-36V	12.0V	1.0A	0.3mA	810mA	680µF	95%	92%	VR10S12
20-36V	15.0V	1.0A	0.3mA	802mA	680µF	96%	93%	VR10S15

Notes

1. Full load input current measured at minimum input voltage.
2. Efficiency measured at full load.
3. Standard tube quantity 43 pcs.

Mechanical Details

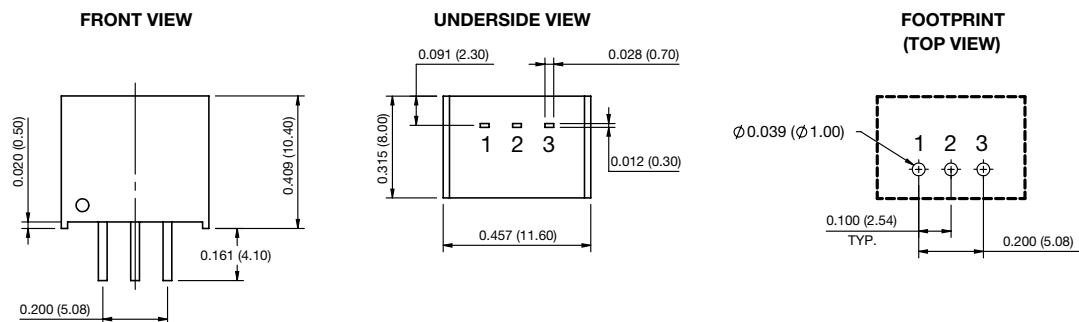

Pin Connections	
Pin	Single
1	+Vin
2	Ground
3	+Vout

Notes

1. All dimensions are in inches (mm)
2. Weight: 0.0041lbs (1.9g) approx.
3. Pin diameter: 0.02±0.004 (0.7±0.1)
4. Case & pin tolerance: ±0.02 (±0.5)

Input

Characteristic	Minimum	Typical	Maximum	Units	Notes & Conditions
Input Voltage Range	6		36	VDC	See Models and Ratings table.
Input Filter	Internal capacitor				
Input Reflected Ripple			20	mA pk-pk	
Input Surge			45	VDC	For max. 100ms.

Output

Characteristic	Minimum	Typical	Maximum	Units	Notes & Conditions
Output Voltage	3.3		15	VDC	See Models and Ratings table.
Initial Set Accuracy		±2.0	±4.0/±3.0	%	3.3V/others (At full load).
Minimum Load	0			mA	No minimum load required.
Line Regulation		±0.2	±0.4	%	Full load over input voltage range.
Load Regulation		±0.4	±0.6	%	Maximum variation applies to 3.3V output models.
Transient Response			±1	%	For 50% load change. Recovery in 100µs.
Ripple & Noise			75	mV pk-pk	20 MHz bandwidth.
Short Circuit Protection	Continuous, with auto recovery.				
Maximum Capacitive Load	See Models and Ratings table.				
Temperature Coefficient			0.03	%/°C	
Overload Protection		2.2		A	
Start-up Time		20		ms	

General

Characteristic	Minimum	Typical	Maximum	Units	Notes & Conditions
Efficiency		93		%	See models and ratings table.
Isolation: Input to Output	0			VDC	Non isolated.
Switching Frequency		520		kHz	At full load.
Mean Time Between Failure	2			MHrs	MIL-HDBK-217F.
Weight		0.0041 (1.9)		lb (g)	
Case Material	Non-conductive black plastic UL94V-0.				
Pin Material	Solder coated phosphor bronze C5191R-1/2H.				
Potting Material	Polyurethane type L780 UL94V-0 rated.				
Water Wash	Use de-ionised water only, dry thoroughly.				
Soldering Temperature			260	°C	Wave solder peak, 1.5mm from case 10s max. Not suitable for vapour phase soldering. For further details contact XP Power applications team.

Environmental

Characteristic	Minimum	Typical	Maximum	Units	Notes & Conditions
Operating Temperature	-40		+85	°C	See derating curves.
Storage Temperature	-55		+125	°C	
Case Temperature			+120	°C	
Humidity			95	%RH	Non-condensing.
Cooling	Natural convection.				

EMC: Emissions

Phenomenon	Standard	Test Level	Notes & Conditions
Conducted	EN55032	Class B	See Application Notes
Radiated	EN55032	Class B	

EMC: Immunity

Phenomenon	Standard	Test Level	Criteria	Notes & Conditions
ESD Immunity	EN61000-4-2	±6kV	B	Contact discharge.
Radiated Immunity	EN61000-4-3	10V/m	A	See Application Notes
EFT/Burst	EN61000-4-4	±1.0kV	B	
Surges	EN61000-4-5	±1.0kV	B	
Conducted Immunity	EN61000-4-6	3Vrms	A	

Application Notes

Input Filter to meet Class B Conducted Emissions

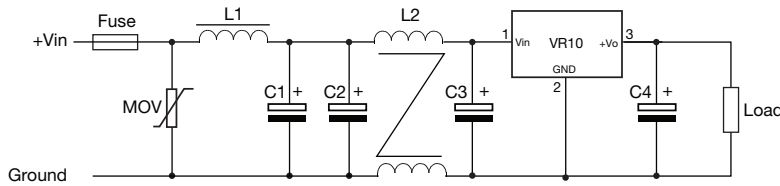

MOV	L1	L2	C1	C2/C3	C4
S20K30	82µH	4.7mH	680µF/50V	4.7µF/50V	see C6

Select fuse rating based on application input current.

Typical Application

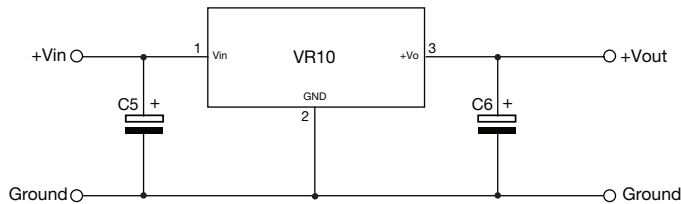

Part Number	C5	C6
VR10S3V3	10µF/50V	22µF/10V
VR10S05		22µF/10V
VR10S6V5		22µF/16V
VR10S09		22µF/16V
VR10S12		22µF/25V
VR10S15		22µF/25V

Derating Curves

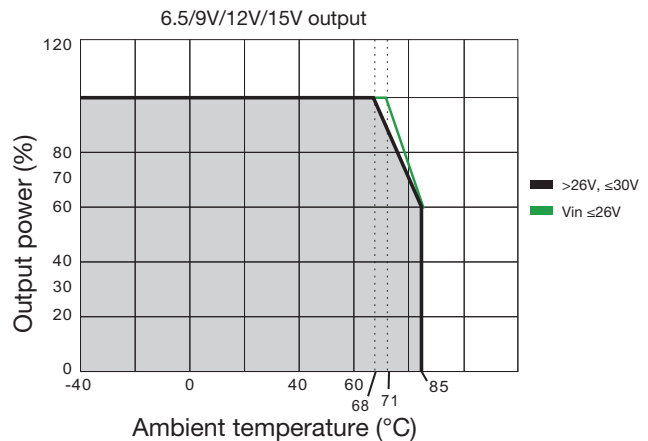
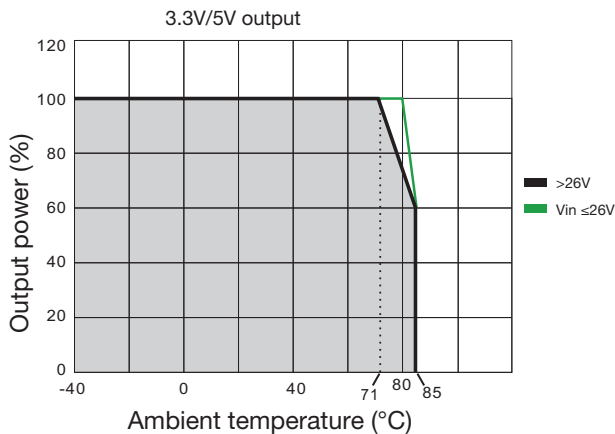

09 July 2020