

IEC61800-5-1 BS EN/EN61800-5-1 TPTC004



■ Features

- 4"x2" miniature size
- 20~55Vdc input
- Controllable with external controller
- Fanless design for no-noise and expanding life cycle
- High surge current 200% up to 5 seconds
- Protections: Short circuit / OCP
- Provided multiple sensors for control:
 Current sensor- motor torque control
 DC bus voltage sensor- OVP/UVP
 Temperature sensor - OTP
- -30~+70°C wide operating temperature
- Suitable for three phase motor drive(BLDC, Induction motor, SynRM)
- 3 years warranty

■ Applications

- Fan
- Pump
- Automatic door
- Portable power tools
- AGV
- Robot
- Auto-packing machine
- Medical device
- Fitness equipment

■ Description

VFD-350P-48 is a variable frequency drive that can be controlled with external PWM controller. The input range is from 20VDC to 55VDC which is suitable for all kinds of installation. It is in size of 4" x 2". VFD-350P-48 able to deliver 200% peak load and with fan-less design, the life time can be extended. VFD is suitable for three-phase motor drive, such as BLDC, Induction motor, SynRM applications.

■ Model Encoding

VFD - 350 P - 48

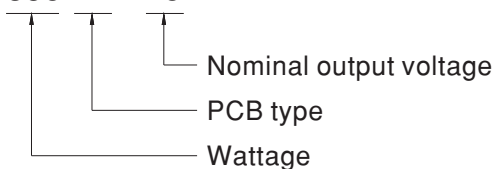

File Name:VFD-350P-48-SPEC 2023-10-18

SPECIFICATION

MODEL NO.		VFD-350P-48		
OUTPUT	VOLTAGE RANGE(UVW) <small>Note.1</small>	Three phase line-to-line 0~34V, suit for 48V class motor		
	CAPACITY	350W		
	CURRENT	10A		
	RATED POWER	350W		
	MAX. CURRENT <small>Note.2</small>	20A		
	EFFICIENCY <small>Note.3</small>	92.5%		
INPUT	RATED INPUT VOLTAGE	20 ~ 55VDC		
	RATED INPUT CURRENT	8.5A/48VDC Typ.		
FUNCTION <small>(Note.5)</small>	INVERTER PWM INPUT	PWM control signal input for driving inverter IGBTs. (PIN8~13 of CN93) TTL input : IGBT ON: High(>2.6V); IGBT OFF: Low(<0.8V) ; Iin =2mA		
	FAULT SIGNAL	Inverter fault signal(Short circuit/OCP, PIN7 of CN93). TTL input: Normal: High(>3V); Abnormal: Low(<0.5V)		
	DC BUS VOLTAGE SENSOR	DC BUS voltage sensor output(HV+ sensor, PIN1 of CN93): 2.5V@DC BUS 48V		
	THREE PHASE CURRENT SENSOR	Built-in 6mΩ low-side shunt resistor (each phase), (PIN4~6 of CN93)		
	THERMAL SENSOR	Built-in 10KΩ NTC for sensing IGBTs operating temperature. (TSM2A103F34D1R (Thinking Electronic), PIN2 of CN93)		
	AUXILIARY POWER VCC	Non-isolated 15V output power for user's application. Max current : 0.2A, Ripple:1V		
PROTECTION	SHORT CIRCUIT	Protection type : Shut down o/p voltage, re-power on to recover		
OUTPUT FREQUENCY	SWITCHING FREQUENCY RANGE	2.5KHz ~ 15KHz		
ENVIRONMENT	COOLING SYSTEM	Air convection		
	WORKING TEMP.	-30 ~ +70°C (Refer to "Dreating Curve")		
	WORKING HUMIDITY	20 ~ 90% RH non-condensing		
	STORAGE TEMP., HUMIDITY	-40 ~ +85°C, 10 ~ 95% RH non-condensing		
	VIBRATION	10 ~ 500Hz, 2G 10min./1cycle, period for 60min. each along X, Y, Z axes		
SAFETY & EMC	SAFETY STANDARDS	CB IEC61800-5-1, TUV BS EN/EN61800-5-1, EAC TP TC004 approved		
	EMC EMISSION	Parameter	Standard	Test Level / Note
		Conducted	BS EN/EN IEC61800-3	Class A, C2
		Radiated	BS EN/EN IEC61800-3	Class A, C2
	EMC IMMUNITY	BS EN/EN IEC61800-3, second environment		
		Parameter	Standard	Test Level / Note
		ESD	BS EN/EN61000-4-2	Level 3, 8KV air ; Level 2, 4KV contact
		Radiated	BS EN/EN IEC61000-4-3	Level 3
		EFT/Burest	BS EN/EN61000-4-4	Level 3
		Surge	BS EN/EN61000-4-5	Level 2, 1KV/Line-Earth ; Level 2, 0.5KV/Line-Line
Conducted		BS EN/EN61000-4-6	Level 3	
Magnetic Field	BS EN/EN61000-4-8	Level 2		
OTHERS	MTBF	3795.1K hrs min.Telcordia SR-332 (Bellcore) ; 292.9K hrs min.MIL-HDBK-217F (25°C)		
	DIMENSION (L*W*H)	101.6*50.8*28.6mm		
	PACKING	0.1kg;96pcs/10.12kg/1.44CUFT		
NOTE	<p>1. 3-phase 48V motor is recommended. Please consider the rated current when used for 12V/24V class motor.</p> <p>2. Refer to peak load usage definition.</p> <p>3. Efficiency is tested by 350W with 20VAC output line-to-line voltage.</p> <p>4. All parameters NOT specially mentioned are measured at 48VDC input, rated load and 25°C of ambient temperature.</p> <p>5. Please refer to page 4 for more details.</p> <p>※ Product Liability Disclaimer : For detailed information, please refer to https://www.meanwell.com/serviceDisclaimer.aspx</p>			

Block Diagram

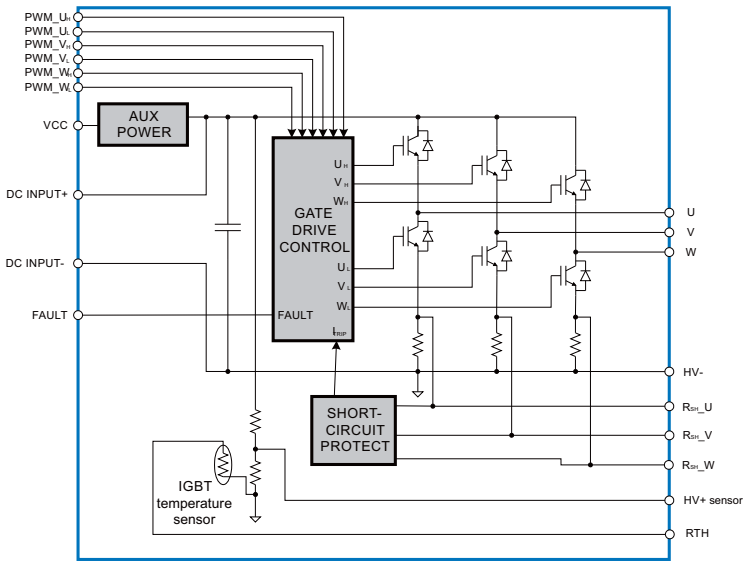

V/I CURVE

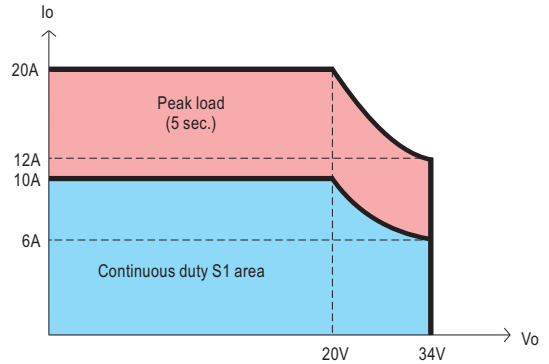

Derating Curve

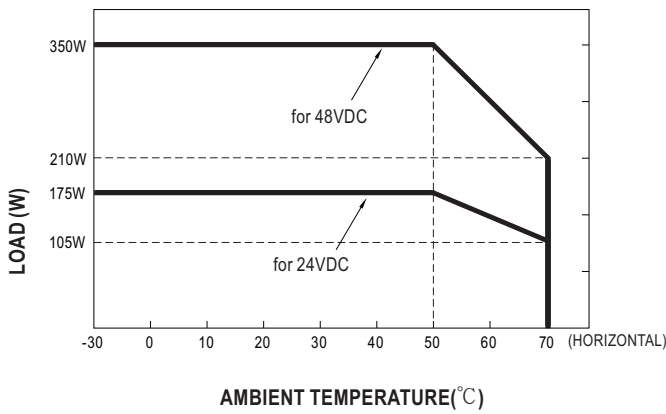

Output Derating VS Input Voltage

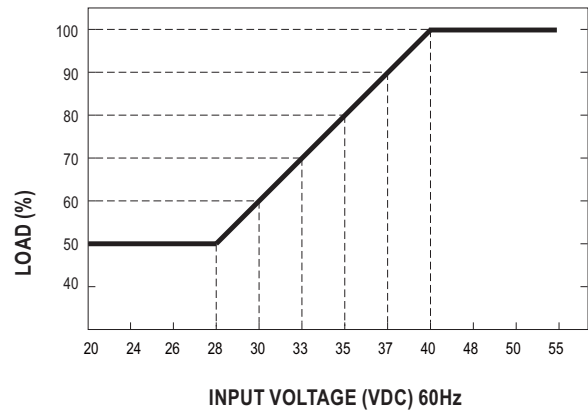

Peak Load

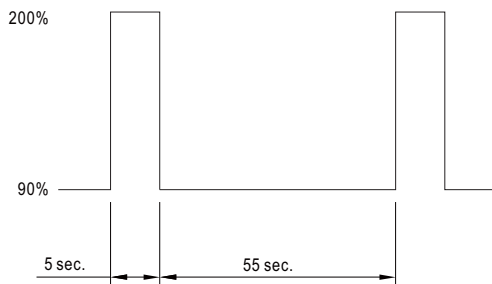

Efficiency vs Load

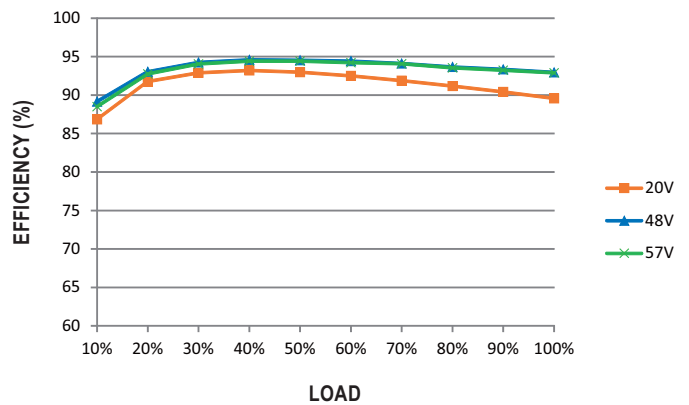

■ **Function Manual**

1. 3-phase PWM Control

VFD-350P-48 provides six-switch circuit by using 3 half-bridge IGBTs. IGBTs of each phase is controlled by PWM_U_H/U_L, PWM_V_H/V_L and PWM_W_H/W_L (PIN 8~13). The input requirement for PWM is compatible with both TTL and CMOS 3.3V signals. Please refer to the diagram below.

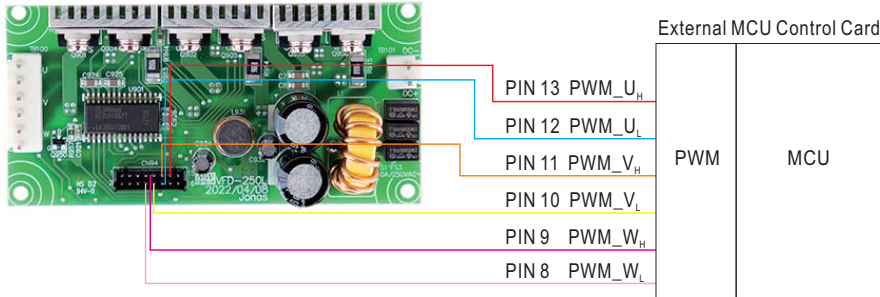

WARNING: It is necessary to keep minimum dead-time 300ns between the upper and lower switch of each phase.

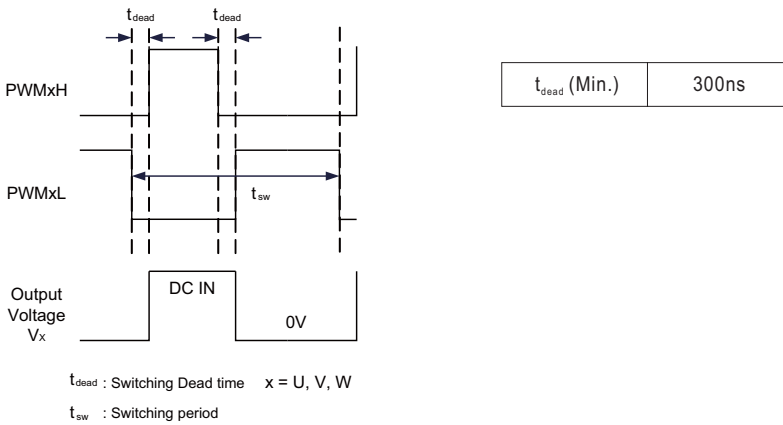

2. 3-phase Current Detection & Overcurrent Protection

Low-side shunt resistors 6mΩ are installed on each phase of VFD-350P-48 for current measurement and short-circuit detection. It's suggested to shorten the length of external detection circuit and detect the signal with a OPAs. Please refer to diagram below.

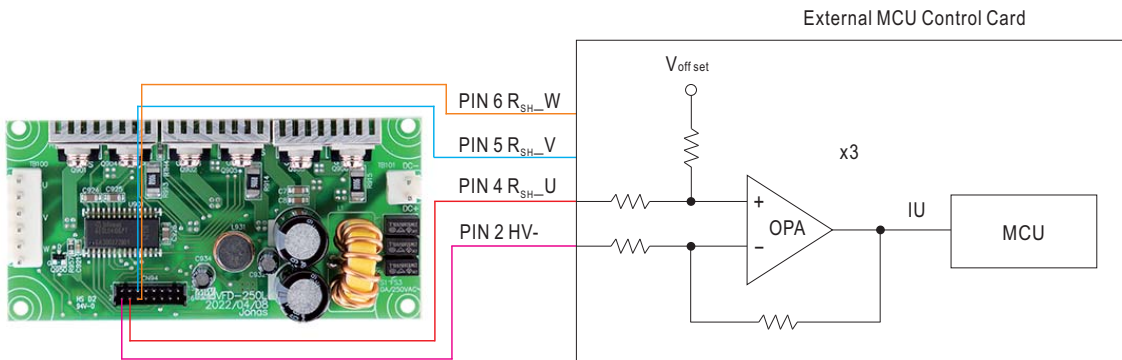

If output current exceed 200% of rated value, the protection circuit will be triggered and shut down the gate driver for protection.

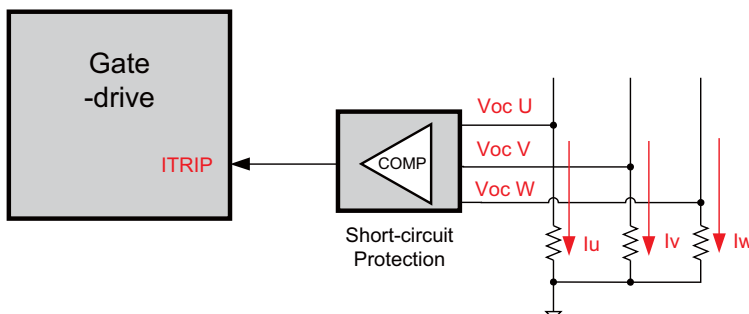

3. DC BUS Voltage Detection

VFD-350P-48 is build-in with DC bus voltage sensor(HV+ sensor, PIN 1). The sensor provides a 2.5V output when DC bus voltage is at 48V. It's suggested to detect the signal by OPAs. When the voltage of the DC bus exceed 60V, the PWM input signal must shut down for protection.

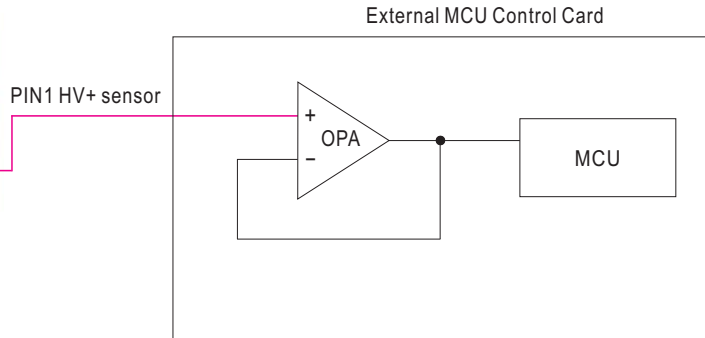
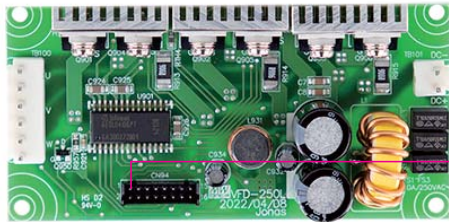

Equation for DC bus voltage calculation:

$$V_{DCBUS} = \frac{48 \times HV+sensor}{2.5}$$

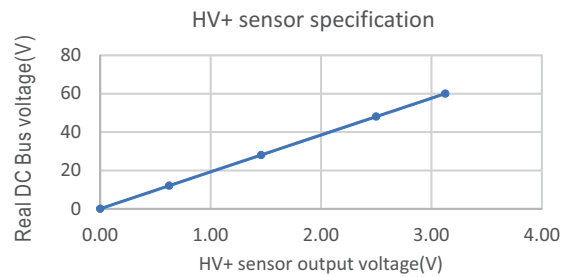

4. MOS Temperature Detection

VFD-350P-48 is build-in a NTC resistor for detecting MOS temperature. Users can detect MOS temperature for protection. (NTC type: TSM2A103F34D1R, Thinking Electronic) The recommended detection circuit is below. It's suggested to shutdown the PWMs input, if the temperture is above 125°C.

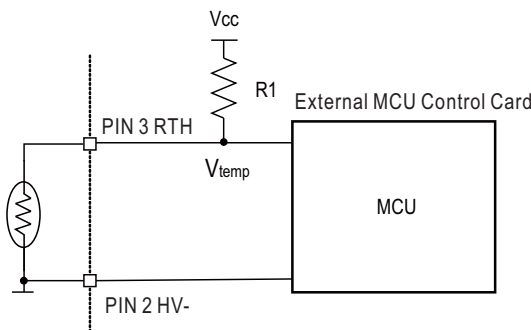

5. Driver Fault signal

The FAULT signal would be active(active-low) to notify external controller or circuit, if VFD-350P-48 encounter the overcurrent state and keep the state for minimum overcurrent tripping time

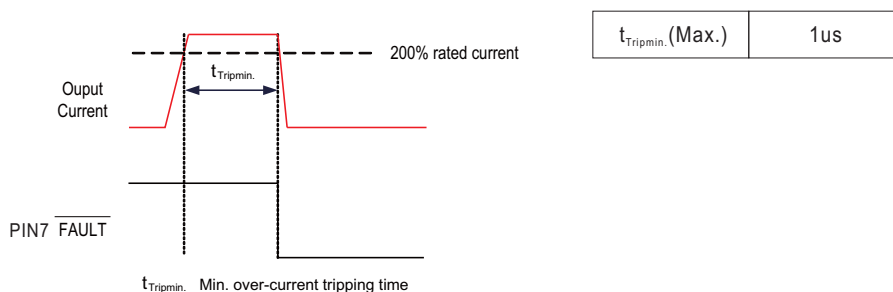

■ Mechanical Specification

Unit:mm

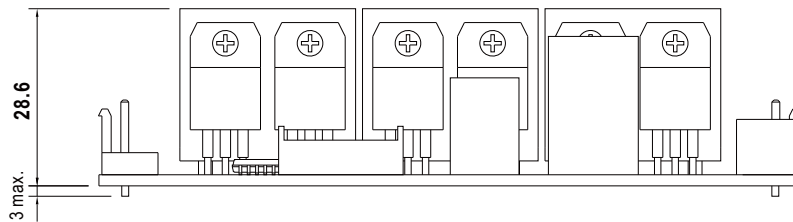
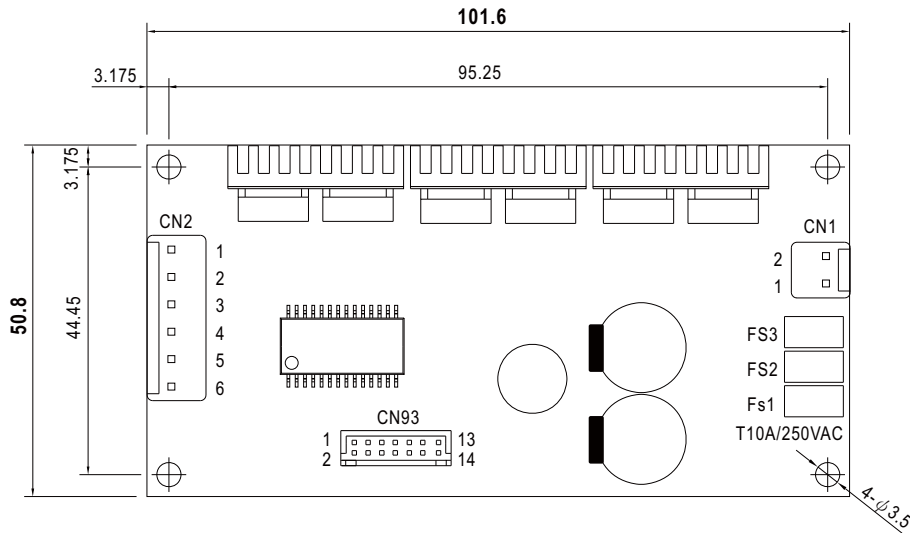

AC Input Connector (CN1) : JST B2P-VH or equivalent

Pin No.	Assignment
1	DC INPUT +
2	DC INPUT -

Mating housing: JST VHR or equivalent
 Terminal: JST SVH-21T-P1.1 or equivalent

PWM Output Connector(CN2): JST B6P-VH or equivalent

Pin No.	Assignment
1,2	U
3,4	V
5,6	W

Mating housing: JST VHR or equivalent
 Terminal: JST SVH-21T-P1.1 or equivalent

Control Pin NO. Assignment (CN93) : HRS DF11-14DP-2DS or equivalent

Pin No.	Assignment	Pin No.	Assignment
1	HV+ sensor	8	PWM_W _H
2	HV-	9	PWM_W _L
3	RTH	10	PWM_V _H
4	R _{SH-U}	11	PWM_V _L
5	R _{SH-V}	12	PWM_U _H
6	R _{SH-W}	13	PWM_U _L
7	FAULT	14	VCC

Mating housing: HRS DF11-14DS or equivalent
 Terminal HRS DF11-**SC or equivalent

※Control Pin No. Assignment(CN93) :

Pin No.	Function	Description
1	HV+ sensor	DC BUS voltage sensor output 2.5V, reference to pin 2(HV-)
2	HV-	DC BUS voltage sensor output ground
3	RTH	Temperature sensor
4	R _{SH} _U	U phase current sensor output
5	R _{SH} _V	V phase current sensor output
6	R _{SH} _W	W phase current sensor output
7	FAULT	Over current detection. Normal > 3V, Abnormal < 0.5V
8	PWM_W _H	W phase high side logic input, on > 2.6V ; off < 0.8V
9	PWM_W _L	W phase low side logic input, on > 2.6V ; off < 0.8V
10	PWM_V _H	V phase high side logic input, on > 2.6V ; off < 0.8V
11	PWM_V _L	V phase low side logic input, on > 2.6V ; off < 0.8V
12	PWM_U _H	U phase high side logic input, on > 2.6V ; off < 0.8V
13	PWM_U _L	U phase low side logic input, on > 2.6V ; off < 0.8V
14	VCC	Auxiliary voltage output 14.5~15.5V reference to pin(HV-). The maximum load current is 0.2A

Application

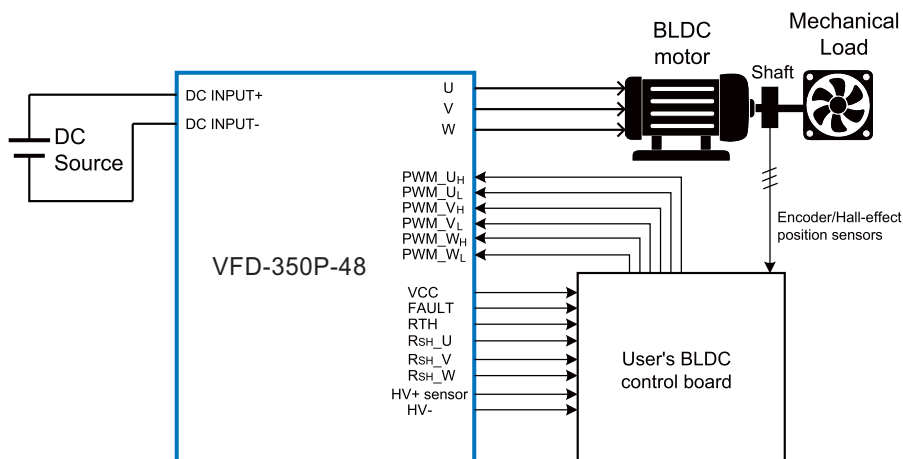

Application example: BLDC drive application



- 1.The figure shows the BLDC drive system which set up with VFD-350P-48.
- 2.Developers can control the PWM signal of 6-switch by using SPWM or SVPWM, etc. for 3-phase voltage modulation, and build the control method base on the current shunt sensors on 3-phase low-side switch(RSHU/V/W) and the DC BUS voltage sensor(HV+ sensor) which provided by VFD-350P-48.
- 3.Developers select the appropriate BLDC position sensors such as encoder or Hall-effect sensors to fit their applications.
- 4.It's suggested to install the brake circuit/device at the DC input for avoiding the DC BUS OVP when BLDC is decelerating.
- 5.It's suggested to shut down the PWM input or connect to brake resistor device for safety when DC Bus voltage is higher than 60V.
- 6.If VFD-350P-48 were applied non-appropriate control, such as accelerating too quickly or bad current control, it might trig the VFD-350P-48's fault-state to shut down the output voltage(low-level on FAULT pin).

■ **Accessory List**

If you have any control requirement of specific application, please consult MEAN WELL for more details.

MW's order No.	Control Board	Assembly Suggestion	Quantity
VFD-CB (optional)			1

■ **Typical Application**

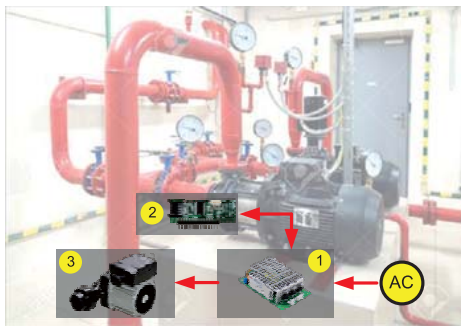

- ① Variable Frequency Module (VFD series)
- ② Control board of Variable Frequency Drive (Designed by User or Solution Provided by MEAN WELL)
- ③ Three-phase Pump Motor

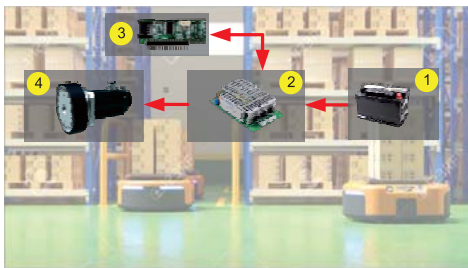

- ① Battery
- ② Variable Frequency Module (VFD series)
- ③ Control board of Variable Frequency Drive (Designed by User or Solution Provided by MEAN WELL)
- ④ Three-phase Wheel Motor for AGV Application

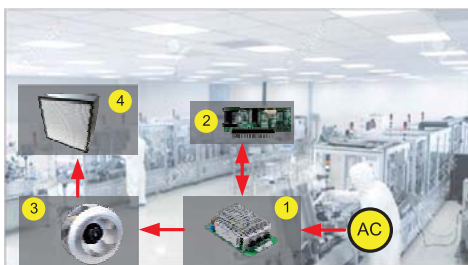

- ① Variable Frequency Module (VFD series)
- ② Control board of Variable Frequency Drive (Designed by User or Solution Provided by MEAN WELL)
- ③ Three-phase Fan Motor
- ④ HEPA for Filtering Air