



- Features :
 - True sine wave output (THD<3%)
 - High surge power up to 3000W
 - High efficiency up to 91%
 - Power ON-OFF switch
 - Standby saving mode can be selectable
 - Front panel indicator for operation status
 - Thermostatically controlled cooling fan
 - Protections: Bat. low alarm / Bat. low shutdown / Over voltage / Over temp. / Output short / Input polarity reverse / Overload
 - Application : Home appliance, power tools, office and portable equipment, vehicle and yacht ...etc.
 - Support RS-232 communication (communication cable order No.: RJ11-RS232, sold sperately) Note.10
 - 3 years warranty



SPECIFICATION

MODEL NO.		TS-1500-112□	TS-1500-124□	TS-1500-148□	TS-1500-212□	TS-1500-224□	TS-1500-248□
		□ = A, F			□ = B, C, D		
OUTPUT	RATED POWER (Typ.)	1500W					
	MAXIMUM OUTPUT POWER (Typ.)	1725W for 180 sec. / 1875W for 10 sec. / surge power 3000W for 30 cycles					
	AC VOLTAGE	100 / 110 / 115 / 120VAC selectable by setting button			200 / 220 / 230 / 240VAC selectable by setting button		
	FREQUENCY Note.9	60±0.1Hz 50/60Hz selectable by setting button S.W			50±0.1Hz 50/60Hz selectable by setting button S.W		
	WAVEFORM Note.2	True sine wave (THD<3%)					
	AC REGULATION (Typ.)	±3.0%					
	SAVING MODE (Typ.)	Default disabled. Load ≤ 5W will be changed to standby mode					
	FRONT PANEL INDICATOR	Battery voltage level, output load level, saving mode, fault and operation status					
INPUT	BAT. VOLTAGE	12V	24V	48V	12V	24V	48V
	VOLTAGE RANGE (Typ.)Note.3,6	10.5 ~ 15VDC	21 ~ 30VDC	42 ~ 60VDC	10.5 ~ 15VDC	21 ~ 30VDC	42 ~ 60VDC
	DC CURRENT (Typ.) Note.5	150A	75A	37.5A	150A	75A	37.5A
	NO LOAD DISSIPATION (Typ.)	≤ 18W @ standby saving mode					
	OFF MODE CURRENT DRAW	≤ 1mA					
	EFFICIENCY (Typ.) Note.2	87%	89%	89%	88%	90%	91%
	BATTERY TYPES	Open & sealed Lead Acid					
BATTERY INPUT PROTECTION	FUSE	40A*5	30A*3	30A*2	40A*5	30A*3	30A*2
	BAT. LOW ALARM	11.3±4%	22.5±4%	45±4%	11.3±4%	22.5±4%	45±4%
	BAT. LOW SHUTDOWN	10.5±4%	21±4%	42±4%	10.5±4%	21±4%	42±4%
	REVERSE POLARITY	By internal fuse open					
OUTPUT PROTECTION	OVER TEMPERATURE	82°C ± 5°C	82°C ± 5°C	96°C ± 5°C	68°C ± 5°C	68°C ± 5°C	68°C ± 5°C
	OUTPUT SHORT	Protection type : Shut down o/p voltage, re-power on to recover					
	OVER LOAD (Typ.)	105 ~ 115% load for 180 sec., 115% ~ 125% load for 10 sec. Protection type : Shut down o/p voltage, re-power on to recover					
	GFCI PROTECTION	UL458 (only for "GFCI" receptacle-Type F)				None	
ENVIRONMENT	WORKING TEMP. Note.1	0 ~ +40°C @ 100% load ; 60°C @ 50% load					
	WORKING HUMIDITY	20% ~ 90% RH non-condensing					
	STORAGE TEMP., HUMIDITY	-30 ~ +70°C / -22 ~ +158°F, 10 ~ 95% RH non-condensing					
	VIBRATION	10 ~ 500Hz, 3G 10min./1cycle, 60min. each along X, Y, Z axes					
SAFETY & EMC	SAFETY STANDARDS	UL458 (only for "GFCI" receptacle-Type F), EAC TP TC 004		EAC TP TC 004	IEC62368-1 CB, EAC TP TC 004 approved; Design refer to BS EN/EN62368-1		
	WITHSTAND VOLTAGE	Bat I/P - AC O/P:3.0KVAC AC O/P - FG:1.5KVAC					
	ISOLATION RESISTANCE	Bat I/P - AC O/P, Bat I/P - FG, AC O/P - FG: 100M ohms / 500VDC / 25°C / 70% RH					
	EMC EMISSION	Compliance to FCC class A, EAC TP TC 020			Compliance to BS EN/EN55032 class B, 72/ 245/ CEE, 95/ 54/ CE, E-Mark, EAC TP TC 020		
	EMC IMMUNITY	Compliance to EAC TP TC 020			Compliance to BS EN/EN61000-4-2,3,8, EAC TP TC 020		
OTHERS	CONTROL WIRING Note.10	RJ11 -RS232 (Option)					
	DIMENSION	420*220*88mm (L*W*H)					
	PACKING	6.81Kg; 2pcs/14.6Kg/1.61CUFT					
NOTE	1.Output derating capacity referenced by curve 1. 2.TH.D and Efficiency is tested by 1000W, linear load at 13V, 26V, 52V input voltage. 3.Input derating capacity referenced by curve 2. 4.All parameters not specified above are measured at rated load, 25°C of ambient temperature and set to factory setting. 5.DC current is tested by 1500W, linear load at 13V, 26V, 52V input voltage. 6.The tolerance of each voltage value by models is:112/212→±0.5V;124/224→±1V;148/248→±2V. 7.Please do not turn on the inverter before start the engine if inverter connect to vehicle's battery directly. 8.The ambient temperature derating of 3.5°C/1000m with fanless models and of 5°C/1000m with fan models for operating altitude higher than 2000m(6500ft). 9.Type F for 60Hz only. 10.The cable is enclosed for the connection between TS-1500 and computer for software monitoring. ※ Product Liability Disclaimer : For detailed information, please refer to https://www.meanwell.com/serviceDisclaimer.aspx						

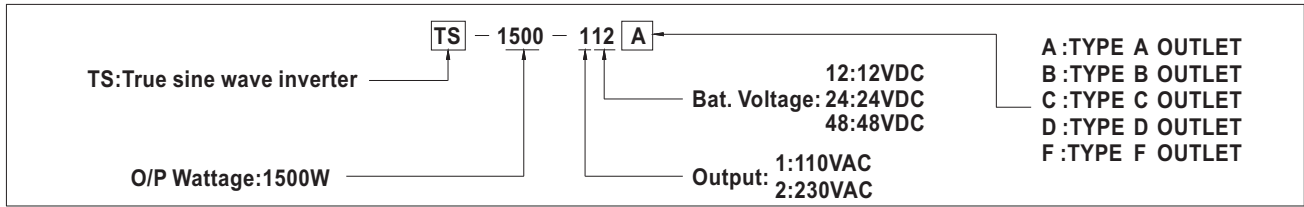

■ AC Output Socket (optional)

MODEL NO.	TS-1500-112 <input type="checkbox"/>	TS-1500-124 <input type="checkbox"/>	TS-1500-148 <input type="checkbox"/>	TS-1500-212 <input type="checkbox"/>	TS-1500-224 <input type="checkbox"/>	TS-1500-248 <input type="checkbox"/>
Socket type						
	TYPE-A	TYPE-F	TYPE-B	TYPE-C	TYPE-D	TYPE-D
	Standard	Optional	Standard	Optional	Optional	Optional
Country	USA	GFCI (60Hz)	EUROPE	AUSTRALIA	U.K	
Certificate						

■ Mechanical Specification

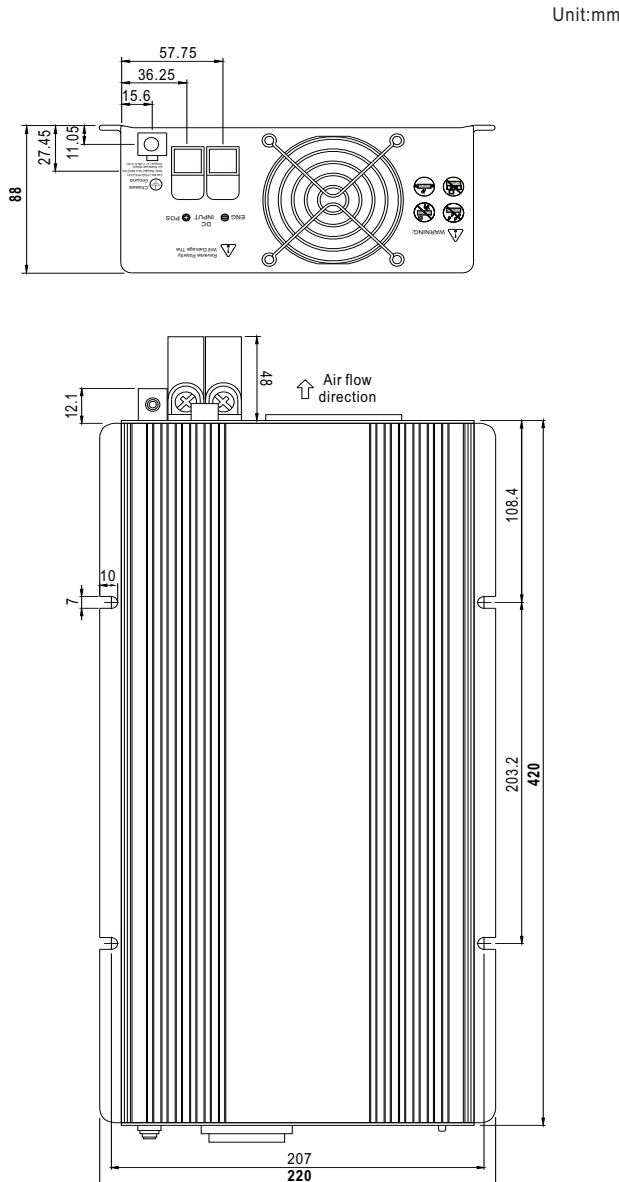

■ Derating Curve

