

- Open frame 100 W power supply with JST connection in 2.0" x 3.0" package
- Certification according to IEC/EN/ES 60601-1 3rd edition for 2 x MOPP
- Low leakage current <75 µA rated for BF applications
- Risk management process according to ISO 14971 incl. risk management file
- Acceptance criteria for electronic assemblies acc. to IPC-A-610 Level 3
- Active power factor correction >0.95
- Protection class I and II prepared
- Operating up to 5000 m altitude
- Ready to meet ErP directive, <0.3 W no load power consumption
- 5-year product warranty

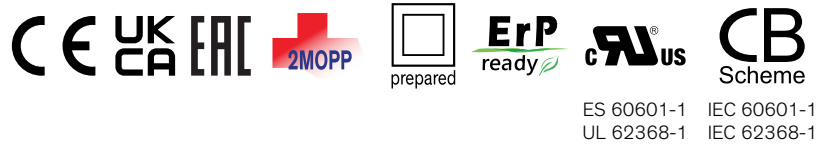

The TPP 100A-J series of 100 Watt AC/DC open frame power supplies feature a reinforced double I/O isolation system according to latest medical safety standards (60601-1 3rd edition, 2 x MOPP). The earth leakage current is below 75 µA which makes the units suitable for BF (body floating) applications. The excellent efficiency of up to 92% allows a high power density for the standard 2.0" x 3.0" packaging format. The full load operating temperature range is -25°C to +55°C while it goes up to 80°C with 50% load derating. The EMC characteristic is dedicated for applications in industrial and medical fields. High reliability is provided by the use of industrial quality grade components and an excellent thermal management. It makes the products an ideal solution for medical devices and for demanding safety and space critical applications.

Models

Order Code	Output Power max.	Output Voltage nom. (adjustable)	Output Current max.	Efficiency typ.
TPP 100-112A-J	100 W	12 VDC (10.8 - 13.2 VDC)	8'340 mA	91 %
TPP 100-115A-J		15 VDC (13.5 - 16.5 VDC)	6'670 mA	92 %
TPP 100-124A-J		24 VDC (21.6 - 26.4 VDC)	4'170 mA	92 %
TPP 100-128A-J		28 VDC (25.2 - 30.8 VDC)	3'580 mA	92 %
TPP 100-136A-J		36 VDC (32.4 - 39.6 VDC)	2'780 mA	91 %
TPP 100-148A-J		48 VDC (43.2 - 52.8 VDC)	2'090 mA	91 %

Options

on demand (backorder with MOQ non stocking item)	- Optional model with 18 VDC / 5'560 mA
---	---

Input Specifications

Input Voltage	- AC Range	Operational Range: 85 - 264 VAC (Full Range) Rated Range: 100 - 240 VAC (Full Range)
	- DC Range	Operational Range: 120 - 370 VDC (Designed for, no certification) Polarity: +DC: L / -DC: N
Input Frequency		Operational Range: 47 - 440 Hz Certified: 50/60 Hz
Input Current	- Full Load & Vin = 230 VAC - Full Load & Vin = 115 VAC	550 mA max. 1'150 mA max.
Power Consumption	- No load & Vin = 230 VAC - No load & Vin = 115 VAC	300 mW max. (Ready to meet ErP directive) 300 mW max.
Input Inrush Current	- At 230 VAC - At 115 VAC	60 A max. 35 A max.
Power Factor	- At 230 VAC - At 115 VAC	0.95 min. (Active Power Factor Correction) 0.95 min. (Active Power Factor Correction)
Input Protection		T 3.15 A / 250 VAC (Internal Fuse in L & N)
Recommended Input Fuse		(The need of an external fuse has to be assessed in the final application.)

Output Specifications

Output Voltage Adjustment		±10% (By trim potentiometer) Output power must not exceed rated power!
Voltage Set Accuracy		±1% max.
Regulation	- Input Variation (Vmin - Vmax) - Load Variation (0 - 100%)	0.2% max. 0.5% max.
Ripple and Noise (20 MHz Bandwidth)		12 VDC model: 120 mVp-p typ. (w/ 10 µF X7R) 15 VDC model: 150 mVp-p typ. (w/ 10 µF X7R) 18 VDC model: 160 mVp-p typ. (w/ 10 µF X7R) 24 VDC model: 160 mVp-p typ. (w/ 1 µF X7R) 28 VDC model: 180 mVp-p typ. (w/ 1 µF X7R) 36 VDC model: 190 mVp-p typ. (w/ 1 µF X7R) 48 VDC model: 340 mVp-p typ. (w/ 0.1 µF X7R)
Capacitive Load		12 VDC model: 6'950 µF max. 15 VDC model: 4'450 µF max. 18 VDC model: 3'100 µF max. 24 VDC model: 1'750 µF max. 28 VDC model: 1'280 µF max. 36 VDC model: 770 µF max. 48 VDC model: 430 µF max.
Minimum Load		Not required
Temperature Coefficient		±0.02 %/K max.
Hold-up Time	- At 230 VAC - At 115 VAC	16 ms min. 16 ms min.
Start-up Time	- At 230 VAC - At 115 VAC	1'000 ms max. 1'000 ms max.
Short Circuit Protection		Continuous, Automatic recovery
Output Current Limitation		115 - 150% of Iout max.
Overvoltage Protection		115 - 135% of Vout nom.
Transient Response	- Response Deviation - Response Time	3% max. (50% to 75% Load Step) 500 µs typ. (50% to 75% Load Step)

All specifications valid at nominal voltage, resistive full load and +25°C after warm-up time, unless otherwise stated.

Safety Specifications

Safety Standards	- IT / Multimedia Equipment	EN 60950-1 EN 62368-1 IEC 60950-1 IEC 62368-1 UL 60950-1 UL 62368-1
	- Medical Equipment	EN 60601-1 IEC 60601-1 ANSI/AAMI ES 60601-1 2 x MOPP (Means Of Patient Protection) www.tracopower.com/overview/tpp100a-j
	- Certification Documents	
	Protection Class	Class I & II (Prepared): Reinforced Insulation
Pollution Degree		PD 2
Over Voltage Category		OVC II

EMC Specifications

EMI Emissions	- Conducted Emissions	EN 60601-1-2 edition 4 (Medical Devices) EN 55011 class B (internal filter) EN 55032 class B (internal filter) FCC Part 15 class B (internal filter) FCC Part 18 class B (internal filter)
	- Radiated Emissions	EN 55011 class A (internal filter) EN 55032 class A (internal filter) FCC Part 15 class A (internal filter) FCC Part 18 class A (internal filter)
	- Harmonic Current Emissions	EN 61000-3-2, class A EN 61000-3-2, class D
	- Voltage Fluctuations & Flicker	EN 61000-3-3
EMS Immunity	- Electrostatic Discharge	EN 55024 (IT Equipment) EN 55035 (Multimedia) EN 60601-1-2 edition 4 (Medical Devices) Air: EN 61000-4-2, ±15 kV, perf. criteria A Contact: EN 61000-4-2, ±8 kV, perf. criteria A EN 61000-4-3, 20 V/m, perf. criteria A EN 61000-4-4, ±2 kV, perf. criteria A L to L: EN 61000-4-5, ±1 kV, perf. criteria A L to PE: EN 61000-4-5, ±2 kV, perf. criteria A EN 61000-4-6, 20 Vrms, perf. criteria A Continuous: EN 61000-4-8, 10 A/m, perf. criteria A 230 VAC / 50 Hz: EN 61000-4-11 30%, 25 periods, perf. criteria A >95%, 0.5 periods, perf. criteria A >95%, 1 period, perf. criteria A >95%, 250 periods, perf. criteria B
	- RF Electromagnetic Field	
	- EFT (Burst) / Surge	
	- Conducted RF Disturbances	
	- PF Magnetic Field	
	- Voltage Dips & Interruptions	115 VAC / 60 Hz: EN 61000-4-11 30%, 25 periods, perf. criteria A >95%, 0.5 periods, perf. criteria A >95%, 1 period, perf. criteria A >95%, 250 periods, perf. criteria B

General Specifications

Relative Humidity		95% max. (non condensing)
Temperature Ranges	- Operating Temperature	-25°C to +85°C
	- Storage Temperature	-40°C to +85°C

All specifications valid at nominal voltage, resistive full load and +25°C after warm-up time, unless otherwise stated.

Power Derating	- High Temperature - Low Input Voltage	2 %/K above 55°C 1.33 %/V below 100 VAC See application note: www.tracopower.com/overview/tpp100a-j
Cooling System		Natural convection (20 LFM)
Altitude During Operation		5'000 m max.
Switching Frequency		45 - 75 kHz (PWM QR)
Insulation System		Reinforced Insulation
Working Voltage (rated)		250 VAC
Isolation Test Voltage	- Input to Output, 60 s - Input to Case or PE, 60 s - Output to Case or PE, 60 s	4'000 VAC 1'500 VAC 1'500 VAC
Isolation Resistance	- Input to Output, 500 VDC	100 MΩ min.
Leakage Current (at 264 VAC)	- Touch Current	75 μA max.
Reliability	- Calculated MTBF	790'000 h (MIL-HDBK-217F, ground benign)
Environment	- Vibration - Mechanical Shock	IEC 60068-2-6 5 g, 3 axis, sine sweep, 5-500 Hz, 1 oct/min IEC 60068-2-27 50 g, 3 axis, half sine, 11 ms
Housing Type		Open Frame
Mounting Type		Chassis Mount
Connection Type		Pin Connector
Weight		156 g
Environmental Compliance	- REACH Declaration - RoHS Declaration	www.tracopower.com/info/reach-declaration.pdf REACH SVHC list compliant REACH Annex XVII compliant www.tracopower.com/info/rohs-declaration.pdf Exemptions: 7a, 7c-I (RoHS exemptions refer to the component concentration only, not to the overall concentration in the product (O5A rule). The SCIP number is provided on request.)

Supporting Documents

Overview Link (for additional Documents)

www.tracopower.com/overview/tpp100a-j

Outline Dimensions

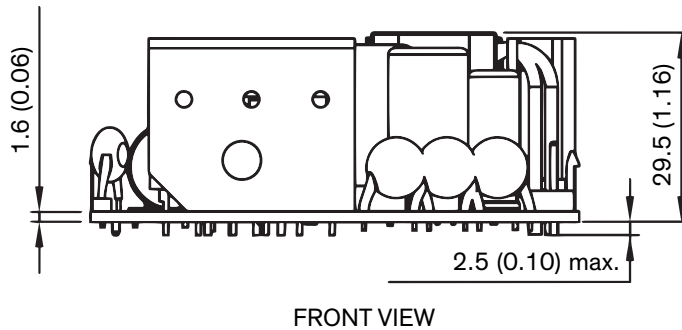
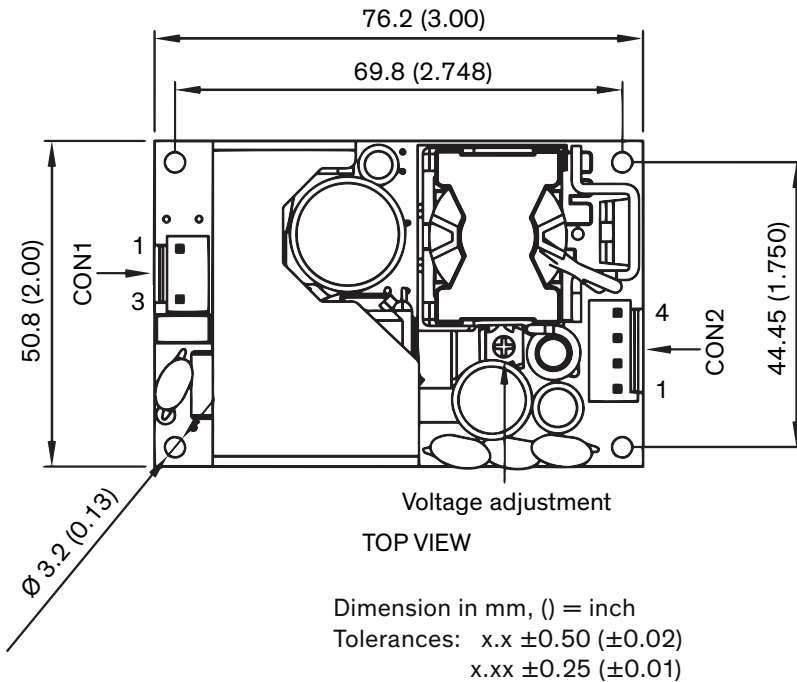

Pin connectors

Input (CON1)		Output (CON2)	
Pin	Function	Pin*	Function
1	Line	1,2	-Vout
3	Neutral	3,4	+Vout

*Terminal rated for 7 A max.
(at higher current connection has to be split)

CON1: JST series
mates with JST crimp terminal: SVH-21T-P1.1
and terminal housing: VHR-3N

CON2: JST series
mates with JST crimp terminal: SVH-21T-P1.1
and terminal housing: VHR-4N