

- 65 Watt open frame power supplies in a 3" x 2" package
- Compact and cost efficient design
- Peak power function up to 140%
- I/O reinforced isolation 3000 VAC
- Operating temperature range -40°C to +85°C
- No load input power <0.3W (acc. ErP directive)
- High efficiency up to 93%
- Internal EN 55032 class B filter
- Protection class II prepared
- 3 year product warranty

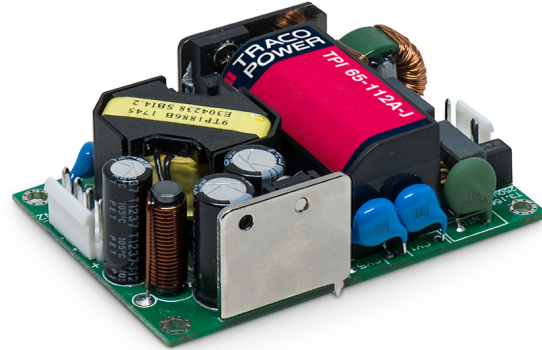

UL 62368-1 IEC 62368-1

The TPI 65A-J is a 65 Watt AC/DC open frame power supplies series with a 3000 VAC reinforced isolation system. Our TPI line specifically focuses on providing cost efficient industrial power supplies in compact designs. This series offers a peak power function which enables the unit to deliver up to 140% of the rated power for up to 10 seconds. Excellent efficiency of up to 93% allows a compact design and an operating temperature range (natural convection) of -40°C to +70°C without derating, while going up to +85°C with either load derating or forced cooling. They are designed to meet the ErP directive (< 0.3 W no load power consumption) and come with an EMC characteristics dedicated for applications in industrial/automation and test & measurement fields. High reliability is provided by use of industrial high-quality grade components and an excellent thermal management. It makes the TPI 65A-J an ideal solution for any demanding industrial devices or space critical applications.

Models					
Order Code	Output Power max.	Output Voltage nom. (adjustable)	Output Current max.	Output Current peak	Efficiency typ.
TPI 65-105A-JP	50 W	5 VDC (4.0 - 5.5 VDC)	10'000 mA	13'000 mA	90 %
TPI 65-112A-JP	65 W	12 VDC (9.6 - 13.2 VDC)	5'420 mA	7'500 mA	93 %
TPI 65-115A-JP		15 VDC (12.0 - 16.5 VDC)	4'340 mA	6'000 mA	94 %
TPI 65-124A-JP		24 VDC (19.2 - 26.4 VDC)	2'710 mA	3'750 mA	94 %
TPI 65-136A-JP		36 VDC (28.8 - 39.6 VDC)	1'810 mA	2'500 mA	93 %
TPI 65-148A-JP		48 VDC (38.4 - 52.8 VDC)	1'360 mA	1'875 mA	93 %
TPI 65-153A-JP		53 VDC (42.4 - 58.3 VDC)	1'240 mA	1'698 mA	93 %

Input Specifications		
Input Voltage	- AC Range	Operational Range: 85 - 264 VAC (Full Range) Rated Range: 100 - 240 VAC (Full Range)
	- DC Range	Operational Range: 120 - 370 VDC (Designed for, no certification) Polarity: +DC: L / -DC: N
Input Frequency		Operational Range: 47 - 440 Hz Certified: 50/60 Hz
Input Current	- Full Load & Vin = 230 VAC	900 mA max.
	- Full Load & Vin = 115 VAC	1'600 mA max.
Power Consumption	- No load & Vin = 230 VAC	180 mW max. (Ready to meet ErP directive)
	- No load & Vin = 115 VAC	180 mW max.
Input Inrush Current	- At 230 VAC	75 A max.
	- At 115 VAC	40 A max.
Input Protection		T 3.15 A / 250 VAC (Internal Fuse in L)
Recommended Input Fuse		(The need of an external fuse has to be assessed in the final application.)

Output Specifications		
Output Voltage Adjustment		-20% to +10% (By trim potentiometer) Output power must not exceed rated power!
Voltage Set Accuracy		±1% max.
Regulation	- Input Variation (Vmin - Vmax)	0.2% max.
	- Load Variation (0 - 100%)	0.7% max. (5 VDC model) 0.5% max. (other output models)
Boost Power		Output Current peak: See model table Peak power time: 5 s max. Peak power duty cycle: 20% max. Average operation power: 70% of full load (detailed description see application note)
Ripple and Noise (20 MHz Bandwidth)	5 VDC model:	75 mVp-p typ. (w/ 10 µF, 25 V, MLCC)
	12 VDC model:	75 mVp-p typ. (w/ 10 µF, 25 V, MLCC)
	15 VDC model:	75 mVp-p typ. (w/ 10 µF, 25 V, MLCC)
	24 VDC model:	75 mVp-p typ. (w/ 1 µF, 50 V, MLCC)
	36 VDC model:	75 mVp-p typ. (w/ 1 µF, 50 V, MLCC)
	48 VDC model:	150 mVp-p typ. (w/ 0.1 µF, 100 V, MLCC)
Capacitive Load	53 VDC model:	150 mVp-p typ. (w/ 0.1 µF, 100 V, MLCC)
	5 VDC model:	20'000 µF max.
	12 VDC model:	4'520 µF max.
	15 VDC model:	2'900 µF max.
	24 VDC model:	1'130 µF max.
36 VDC model:	520 µF max.	
48 VDC model:	285 µF max.	
53 VDC model:	235 µF max.	
Minimum Load		Not required
Temperature Coefficient		±0.02 %/K max.
Hold-up Time	- At 230 VAC	90 ms min.
	- At 115 VAC	15 ms min.
Start-up Time	- At 230 VAC	800 ms max.
	- At 115 VAC	950 ms max.
Short Circuit Protection		Continuous, Automatic recovery
Output Current Limitation		165% typ. of Iout max.
Overvoltage Protection		125 - 140% of Vout nom.
Transient Response	- Response Deviation	3% max. (50% to 75% Load Step at 2.5 A/µs)
	- Response Time	600 µs typ. (50% to 75% Load Step at 2.5 A/µs)

All specifications valid at nominal voltage, resistive full load and +25°C after warm-up time, unless otherwise stated.

Safety Specifications

Safety Standards	- IT / Multimedia Equipment	EN 62368-1 IEC 62368-1 UL 62368-1
	- Certification Documents	www.tracopower.com/overview/tpi65a-j
Protection Class		Class I & II (Prepared): Reinforced Insulation
Pollution Degree		PD 2

EMC Specifications

EMI Emissions	- Conducted Emissions	EN 55011 class B (internal filter) EN 55032 class B (internal filter) FCC Part 15 class B (internal filter)
	- Radiated Emissions	EN 55011 class B (internal filter) EN 55032 class B (internal filter) FCC Part 15 class B (internal filter)
	- Harmonic Current Emissions	EN 61000-3-2, class A
	- Voltage Fluctuations & Flicker	EN 61000-3-3
EMS Immunity	- Electrostatic Discharge	EN 55024 (IT Equipment) EN 55035 (Multimedia) Air: EN 61000-4-2, ±15 kV, perf. criteria A Contact: EN 61000-4-2, ±6 kV, perf. criteria A
	- RF Electromagnetic Field	EN 61000-4-3, 20 V/m, perf. criteria A
	- EFT (Burst) / Surge	EN 61000-4-4, ±4 kV, perf. criteria A L to L: EN 61000-4-5, ±2 kV, perf. criteria A L to PE: EN 61000-4-5, ±4 kV, perf. criteria A
	- Conducted RF Disturbances	EN 61000-4-6, 20 Vrms, perf. criteria A
	- PF Magnetic Field	Continuous: EN 61000-4-8, 100 A/m, perf. criteria A
	- Voltage Dips & Interruptions	230 VAC / 50 Hz: EN 61000-4-11 115 VAC / 60 Hz: EN 61000-4-11

General Specifications

Relative Humidity		95% max. (non condensing)
Temperature Ranges	- Operating Temperature	-40°C to +85°C
	- Storage Temperature	-40°C to +85°C
Power Derating	- High Temperature	Depending on model
	- Low Input Voltage	4 %/V below 90 VAC
		See application note: www.tracopower.com/overview/tpi65a-j
Cooling System		Natural convection (20 LFM)
Altitude During Operation		5'000 m max.
Switching Frequency		60 kHz typ. (PWM QR) (5 VDC models) 120 kHz typ. (PWM QR) (other models)
Insulation System		Reinforced Insulation
Working Voltage (rated)		273 VAC
Isolation Test Voltage	- Input to Output, 60 s	3'000 VAC
Creepage	- Input to Output	8 mm min.
Clearance	- Input to Output	8 mm min.
Isolation Resistance	- Input to Output, 500 VDC	100 MΩ min.
Leakage Current	- Earth Leakage Current	75 μA max.
	(at 264 VAC)	
Distance Through Isolation		0.4 mm
Reliability	- Calculated MTBF	1'490'000 h (MIL-HDBK-217F, ground benign)
Environment	- Vibration	IEC 60068-2-6
	- Mechanical Shock	IEC 60068-2-27
Housing Type		Open Frame
Mounting Type		Chassis Mount
Connection Type		Pin Connector

All specifications valid at nominal voltage, resistive full load and +25°C after warm-up time, unless otherwise stated.

Weight

117 g

Environmental Compliance - REACH Declaration

www.tracopower.com/info/reach-declaration.pdf

- RoHS Declaration

REACH SVHC list compliant

REACH Annex XVII compliant

www.tracopower.com/info/rohs-declaration.pdf

Exemptions: 7a, 7c-I

(RoHS exemptions refer to the component concentration only, not to the overall concentration in the product (O5A rule). The SCIP number is provided on request)

Supporting Documents

Overview Link (for additional Documents)

www.tracopower.com/overview/tpi65a-j

Outline Dimensions

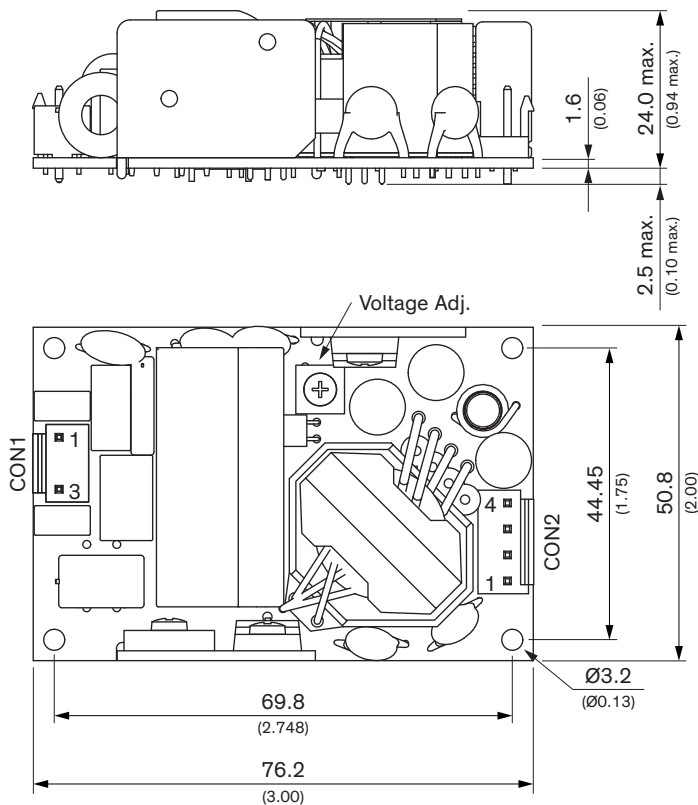

Dimensions in mm (inch)
Tolerances: x.x ±0.5 (x.xx ±0.02)
Tolerances: x.xx±0.25 (x.xxx ±0.01)
Screw lock torque: Max. 0.49 Nm (5 kgfcm)

Pin connectors

Input (CON1)		Output (CON2)	
Pin	Function	Pin	Function
1	Line	1,2*	-Vout
3	Neutral	3,4*	+Vout

*Terminal rated for 10 A max per pin.
(at higher current connection has to be split)

Input: JST series
mates with JST crimp terminal: SVH-21T-P1.1
and terminal housing: VHR-3N

Output: JST series
mates with JST crimp terminal: SVH-21T-P1.1
and terminal housing: VHR-4N