



(Bottom View)



## ■ Features

- Quarter-brick(2.28" x 1.45" x 0.5") with industrial standard pin-out
- Compliance with railway standard EN50155
- 12:1(14~160Vdc) ultra-wide input range
- Wide operating temperature range -40 ~ +90°C
- No minimum load required
- Full encapsulated
- Protections: Short circuit (Continuous) / Overload / Over temperature / Over voltage / Input under voltage
- 3KVDC or 2KVAC I/O isolation
- Remote ON/OFF control and remote sense
- Trimming output(±10%)
- 3 years warranty

## ■ Applications

- Bus, tram, metro or railway system
- Telecom/datacom system
- Wireless network
- Industrial control facility
- Instrument
- Analyzer
- Highly vibrating, heavily dusty, extremely low or high temperature harsh environment

## ■ Description

RQB40W12 series is 40W module type DC-DC reliable railway with quarter brick package. It features international standard pins, a high efficiency up to 90%, wide working temperature range -40~+90°C , 3KVDC or 2KVAC I/P-O/P isolation voltage, meet EN50155 with external circuits, continuous-mode short circuit protection, etc. The models input for 14~160VDC 12:1 ultra-wide input range, and various output voltage, 5V/12V/24V/48V/54V for single output, which are suitable for railway, trams, buses and also can be used in the harsh environment with high vibration, high dust, extremely low or high temperature, etc.

## ■ Model Encoding

RQB 40 W12 – 110 S 05

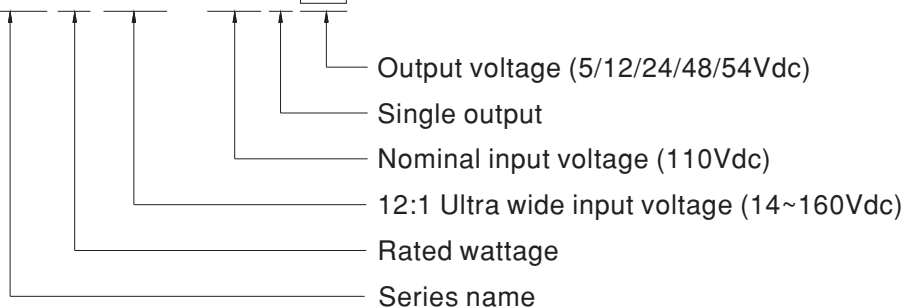

File Name:RQB40W12-SPEC 2022-12-12

MODEL SELECTION TABLE							
ORDER NO.	INPUT			OUTPUT		EFFICIENCY (Typ.)	CAPACITOR LOAD (MAX.)
	INPUT VOLTAGE (RANGE)	INPUT CURRENT		OUTPUT VOLTAGE	OUTPUT CURRENT		
		NO LOAD	FULL LOAD				
RQB40W12-110S05	Nominal 24V,36V,48V,72V,96V,110V (14 ~ 160V)	15mA	420mA	5V	8A	88%	24000μF
RQB40W12-110S12		15mA	420mA	12V	3.333A	89%	3900μF
RQB40W12-110S24		15mA	420mA	24V	1.667A	88%	820μF
RQB40W12-110S48		15mA	410mA	48V	0.833A	89%	220μF
RQB40W12-110S54		15mA	410mA	54V	0.741A	90%	150μF

SPECIFICATION				
INPUT	VOLTAGE RANGE	14 ~ 160Vdc		
	SURGE VOLTAGE (1s max.)	200Vdc		
	FILTER	Pi type		
	PROTECTION	7A fast acting fuse		
	SETUP TIME	40ms(100% Load at Nominal Vin)		
OUTPUT	VOLTAGE ACCURACY	± 1.0%		
	RATED POWER	40W		
	RIPPLE & NOISE <small>Note.2</small>	150mVp-p		
	LINE REGULATION <small>Note.3</small>	± 0.2%		
	LOAD REGULATION <small>Note.4</small>	± 0.2%		
	SWITCHING FREQUENCY (Typ.)	250KHz		
	EXTERNAL TRIM ADJ. RANGE (Typ.)	± 10%		
	HOLD UP TIME	Please refer to page 5 & 6 Hold up time		
PROTECTION	SHORT CIRCUIT	Protection type : Continuous, automatic recovery		
	OVERLOAD	110 ~ 180% rated output power Protection type : Recovers automatically after fault condition is removed		
	OVER VOLTAGE	Protection type : Clamp by zener diode		
	OVER TEMPERATURE	+115°C thermal shutdown, recovers automatically after fault condition is removed		
	UNDER VOLTAGE LOCKOUT (Table 3)	Start-up voltage	13.6V	
		Shutdown voltage	12.7V	
FUNCTION	REMOTE CONTROL	Power ON: R.C ~ -Vin > 3 ~ 12Vdc or open circuit Power OFF: R.C ~ -Vin < 1.2Vdc or short		
ENVIRONMENT	COOLING	Free-air convection		
	WORKING TEMP.	-40 ~ +90°C (Refer to "Derating Curve")		
	CASE TEMPERATURE	+105°C max.		
	WORKING HUMIDITY	5% ~ 90% RH non-condensing		
	STORAGE TEMP., HUMIDITY	-55 ~ +125°C, 10 ~ 95% RH non-condensing		
	TEMP. COEFFICIENT	0.05% / °C (0 ~ 65°C)		
	SOLDERING TEMPERATURE	1.5mm from case of 3 ~ 5sec./260°C max.		
	VIBRATION	EN61373		
	OPERATING ALTITUDE	3000 meters		
SAFETY & EMC (Note.5)	SAFETY STANDARDS	CB IEC62368-1, UL62368-1, EAC TP TC 020/2011 approved		
	WITHSTAND VOLTAGE	I/P-O/P:3KVDC or 2KVAC		
	ISOLATION RESISTANCE	I/P-O/P:1000M Ohms / 500VDC / 25°C / 70% RH non-condensing		
	ISOLATION CAPACITANCE (Typ.)	1500pF		
	EMC EMISSION	Parameter	Standard	Test Level / Note
		Conducted	BS EN/EN55032	Class A/B with external components
		Radiated	BS EN/EN55032	Class A/B with external components
	EMC IMMUNITY	Parameter	Standard	Test Level / Note
		ESD	BS EN/EN61000-4-2	Level 3, ±8KV air, ±6KV contact
		Radiated Susceptibility	BS EN/EN61000-4-3	Level 3, 10V/m
		EFT/Burest	BS EN/EN61000-4-4	Level 3, On power input port, ±2KV external input capacitor required
		Surge	BS EN/EN61000-4-5	Line to Line, ±2KV
		Conducted	BS EN/EN61000-4-6	Level 3, 10V/m
		Magnetic Field	BS EN/EN61000-4-8	Level 3, 10V/m
RAILWAY STANDARD	EN50155 / IEC60571 including EN61373 for shock & vibration, EN50121-3-2 for EMC			
OTHERS	MTBF	205Khrs MIL-HDBK-217F(25°C)		
	DIMENSION (L*W*H)	57.9*36.8*12.7mm (2.28*1.45*0.5 inch)		
	CASE MATERIAL	Aluminum base plate with plastic case		
	PACKING	68g ; 11pcs/per tube, 132pcs/12 tube/per carton		
NOTE	1.All parameters are specified at normal input(110Vdc), rated load, 25°C 70% RH ambient. 2.Ripple & noise are measured at 20MHz by using a 12" twisted pair terminated with a 0.1µf & 47µf capacitor. 3.Line regulation is measured from low line to high line at rated load. 4.Load regulation is measured from 0% to 100% rated load. 5.The final equipment must be re-confirm that it still meet EMC directives. For guidance on how to perform these EMC tests, please refer to "EMI testing of component power supplies."(as available on <a href="http://www.meanwell.com">http://www.meanwell.com</a> ) ※ Product Liability Disclaimer : For detailed information, please refer to <a href="https://www.meanwell.com/serviceDisclaimer.aspx">https://www.meanwell.com/serviceDisclaimer.aspx</a>			

### External Output Trimming

In order to trim the voltage up or down, one needs to connect the trim resistor either between the trim pin and -Vout for trim\_up or between trim pin and +Vout for trim\_down. The output voltage trim range is -10% to +10%. This is shown in Figures 1 and 2:

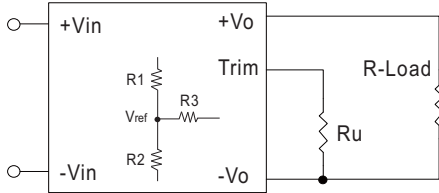

Figure 1. Trim\_up Voltage Setup

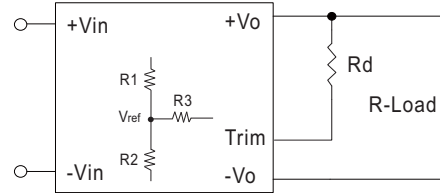

Figure 2. Trim\_down Voltage Setup

#### 1. The value of Rtrim\_up defined as:

$$A = \frac{V_{ref}}{V_o' - V_{ref}} \times R1$$

$$R_{trim\_up} = \frac{AR2}{R2 - A} - R3$$

For example, to trim\_up the output voltage of 5.0V module (RQB40W12-110S05) by 10% to 5.5V, Rtrim\_up is calculated as follows:

$$V_{o,nom} = 5V$$

$$V_o' = 5.5V$$

$$V_{ref} = 1.25V$$

$$R1 = 30.3 K\Omega$$

$$R2 = 10 K\Omega$$

$$R3 = 68K\Omega$$

$$A = \frac{V_{ref}}{V_o' - V_{ref}} \times R1$$

$$= \frac{1.25}{5.5 - 1.25} \times 30.3 = 8.911$$

$$R_{trim\_up} = \frac{AR2}{R2 - A} - R3$$

$$= \frac{8.911 \times 10}{10 - 8.911} - 68$$

$$= 13.827K\Omega$$

#### 2. The value of Rtrim\_down defined as:

$$A = \frac{V_o' - V_{ref}}{V_{ref}} \times R2$$

$$R_{trim\_down} = \frac{AR1}{R1 - A} - R3$$

For example, to trim\_down the output voltage of 5.0V module (RQB40W12-110S05) by 10% to 4.5V, Rtrim\_down is calculated as follows:

$$V_{o,nom} = 5V$$

$$V_o' = 4.5V$$

$$V_{ref} = 1.25V$$

$$R1 = 30.3 K\Omega$$

$$R2 = 10 K\Omega$$

$$R3 = 68 K\Omega$$

$$A = \frac{V_o' - V_{ref}}{V_{ref}} \times R2$$

$$= \frac{4.5 - 1.25}{1.25} \times 10 = 2.6 \times 10 = 26$$

$$R_{trim\_down} = \frac{AR1}{R1 - A} - R3$$

$$= \frac{26 \times 30.3}{30.3 - 26} - 68$$

$$= 115.2K\Omega$$

Table 1 – Trim\_up and Trim\_down Resistor Values

Model Number	Vo,nom (V)	Vref (V)	R1 (KΩ)	R2 (KΩ)	R3 (KΩ)
RQB40W12-110S05	5	1.25	30.3	10	68
RQB40W12-110S12	12	2.5	12.56	3.3	24.9
RQB40W12-110S24	24	2.5	17.2	2	15
RQB40W12-110S48	48	2.5	36.4	2	15.8
RQB40W12-110S54	54	2.5	41.2	2	15.8

Note:

1. Rtrim\_up, Rtrim\_down is mean trim resistor, please check the formula.
2. A & B: user define parameter, no actual meanings.
3. Vo' is target trim voltage.
4. Value for R1, R2, R3 and Vref refer to above table.

### ■ Hold-up Time

As Figure 3 shows, an electrolytic cap (Cbus) about 47μF connected between Vbus and -Vin is necessary. The Vbus can provide or absorb transient power and make the converter operating stable.

In Figure 4 when input voltage is below 56Vdc, the Vbus voltage will keep at 60V. As the input voltage increase and over 60V, the Vbus and Vin will had the same voltage level.

During the transition of different power source, the electric power on the train become unstable in a short time. Such as a sudden voltage drop or a short-term power failure. Under this situation, hold-up time circuit is suitable for this situation.

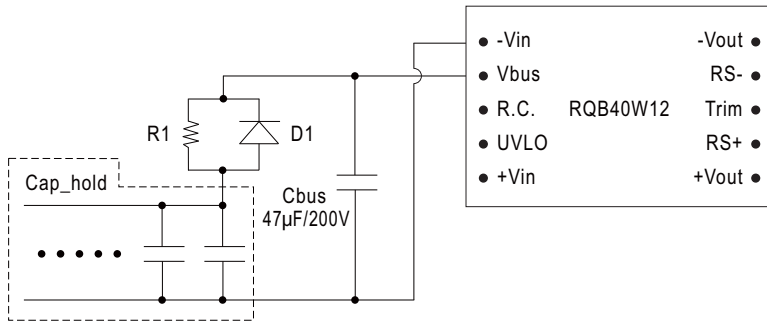

Figure 3 Vbus circuit for hold up Cap

Table 2 – Cap\_hold table (Hold up time)

Nominal Vin	24V	48V	72V	96V	110V
10ms(S2)	800μF	800μF	440μF	180μF	120μF
20ms(S3)	1600μF	1600μF	800μF	440μF	300μF
30ms(C2)	2200μF	2200μF	1200μF	540μF	400μF

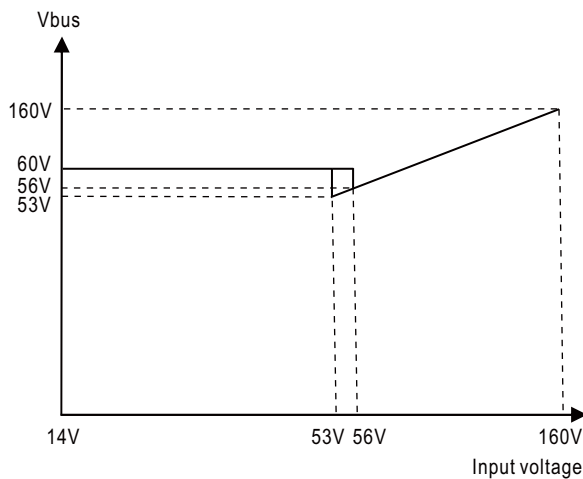

Figure 4 Input and Vbus voltage relationship

As Figure 3 shows, hold-up time circuit comprises R1, D1 and Cap\_hold. The capacity of Cap\_hold decides the hold-up time during interruption of input power. And Table 2 shows the table for Cap\_hold with different input voltage. For Example, if input voltage is 24V, and output load is full load. The Cap\_hold need 800μF for hold-up 10ms.

During start up, R4 endures a high pulse power, and should be selected carefully. The power is related to Vbus and Cap\_hold. We recommend to use 25 ohm/10W resistor.

**UVLO**

The under voltage threshold can set by external resistor placed between the UVLO and -Vin. (Please refer to Table 3)

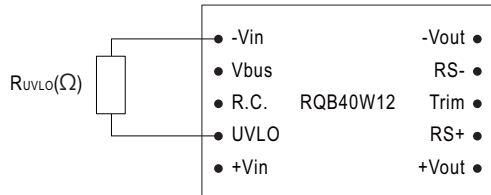
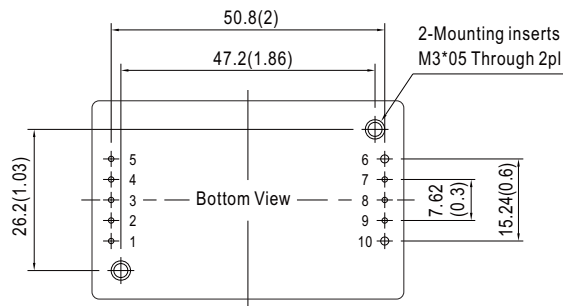
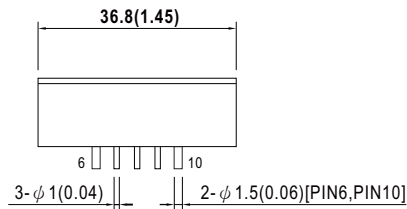
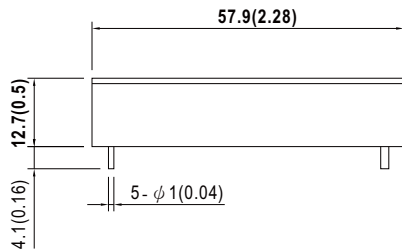

Table 3 – UVLO

UVLO External Resistor $R_{UVLO}(\Omega)$	OPEN	140K	62K
<b>Shutdown</b>	12.7V	19.6V	26.3V
<b>Start up</b>	13.6V	20.4V	27.3V

**Mechanical Specification**

- All dimensions in mm(inch)
- Tolerance:  $x.x \pm 0.5\text{mm}$  ( $x.x \pm 0.02"$ )  
 $x.xx \pm 0.25\text{mm}$  ( $x.xx \pm 0.01"$ )
- Pin size is:  $1.x \pm 0.1\text{mm}$  ( $0.04" \pm 0.005"$ )



**Plug Assignment**

Pin-Out			
Pin No.	Output	Pin No.	Output
1	+Vin	6	-Vout
2	UVLO	7	RS-
3	Remote ON/OFF	8	Trim
4	Vbus	9	RS+
5	-Vin	10	+Vout

**Derating Curve**

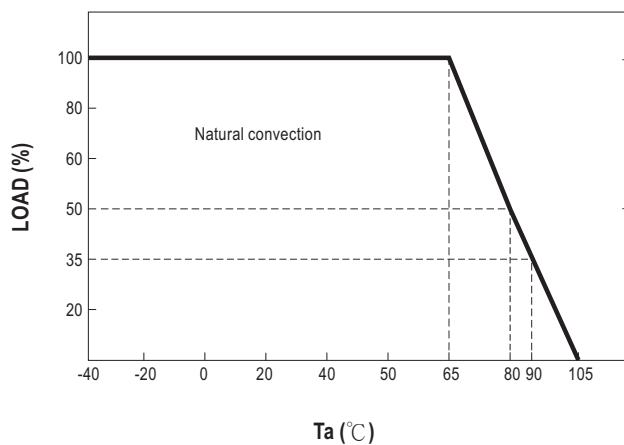

■ EMC Suggestion Circuit

※ EMI Test standard: BS EN/EN55032 Class A Output Conducted & Radiated Emission are as below:  
(Test Condition: Input Voltage: 110Vdc, Output Load: Full Load)

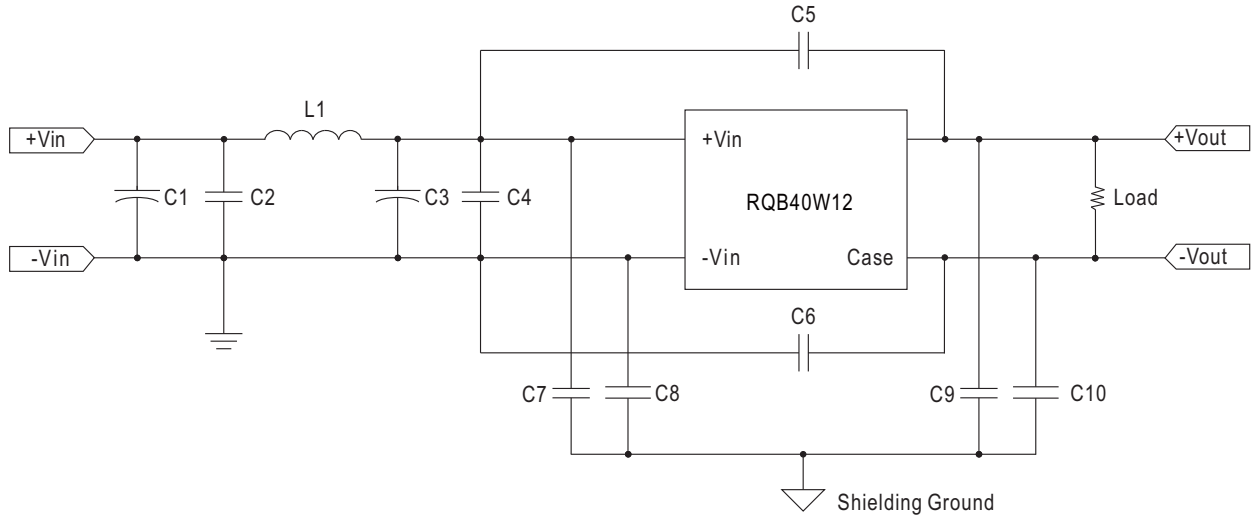

Model No.	BS EN/EN55032 Class A						
	C1	C2,4	C3	C5	C6	C7,8,9,10	L1
RQB40W12-110S05	100 $\mu$ F/200V Aluminum Cap.	0.68 $\mu$ F/250V Ceramic Cap.	47 $\mu$ F/200V Aluminum Cap.	1000pF/3KV	1000pF/3KV Ceramic Cap.	1000pF/2KV Ceramic Cap.	10 $\mu$ H GSTD1265PE- 100M
RQB40W12-110S12				2200pF/3KV			
RQB40W12-110S24							
RQB40W12-110S48							
RQB40W12-110S54							

※ EMI Test standard: BS EN/EN55032 Class B Output Conducted & Radiated Emission are as below:  
(Test Condition: Input Voltage: 110Vdc, Output Load: Full Load)

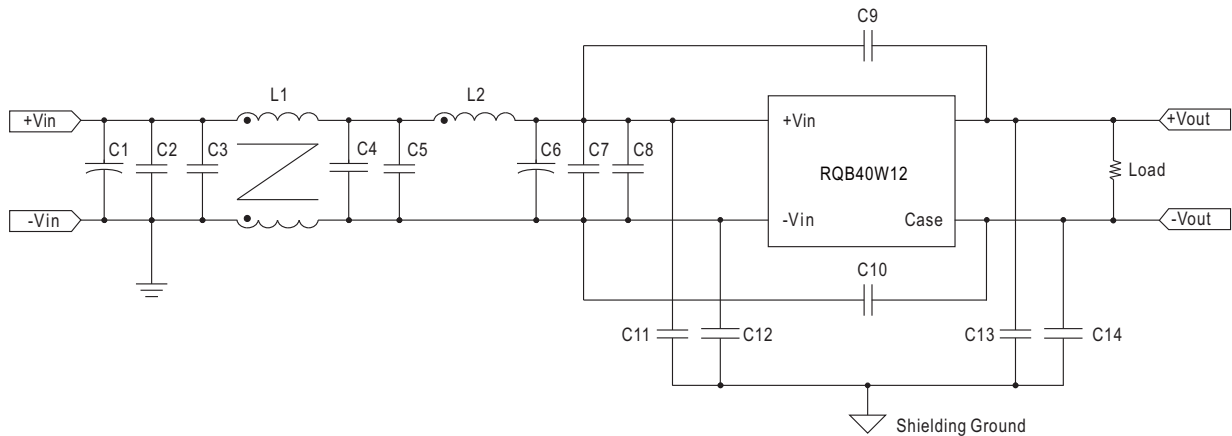

Model No.	BS EN/EN55032 Class B							
	C1	C2,3,4,5,7,8	C6	C9	C10	C11,12,13,14	L1	L2
RQB40W12-110S05	100 $\mu$ F/200V Aluminum Cap.	0.68 $\mu$ F/250V Ceramic Cap.	47 $\mu$ F/200V Aluminum Cap.	2200pF/3KV Ceramic Cap.	2200pF/3KV	3300pF/2KV Ceramic Cap.	Common Choke A10 T16x12x8C 2.2mH $\pm$ 35%	4.7 $\mu$ F GSTD1265PE 4R7M
RQB40W12-110S12					1000pF/3KV			
RQB40W12-110S24								
RQB40W12-110S48								
RQB40W12-110S54					1000pF/3KV			

■ Packing

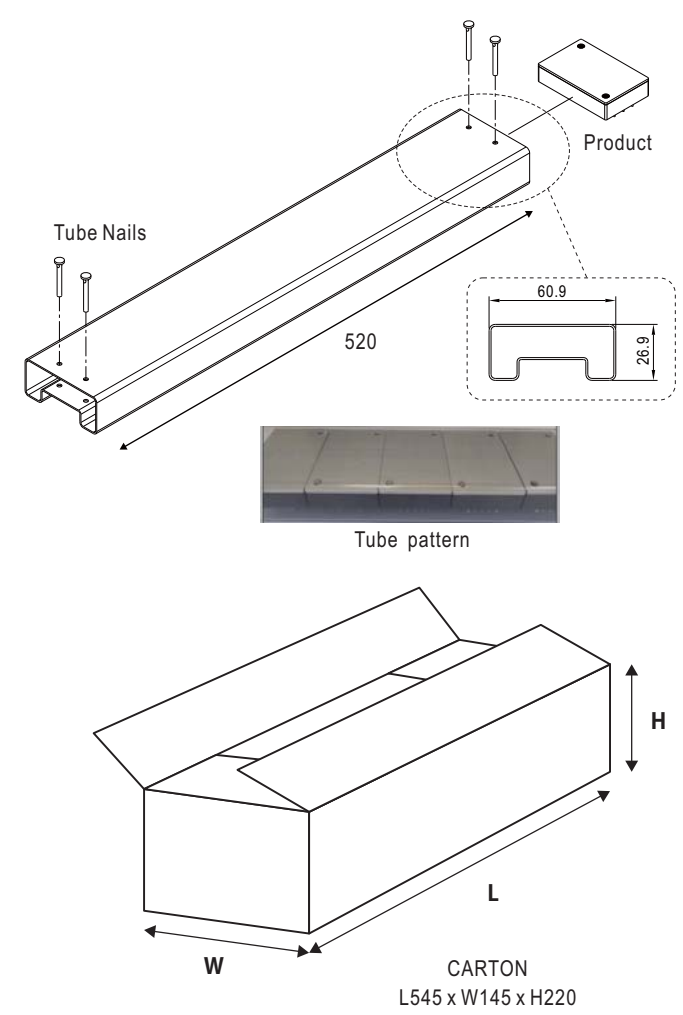
Standard Tube Packing	MPQ Per Tube (PCS)	One Tube G.W.	Max. Q'TY/ Carton(PCS)	One Carton G.W.
<p>Unit : mm</p> 	11	880g	132	10.88Kg