

## 1/2 Watt

- Output voltages from 100VDC to 10,000VDC
- Output proportional to input
- 0.7VDC turn-on voltage
- Wide operating temperature range
- Short circuit protection
- Low ripple <1%
- 500VDC input to output isolation
- No minimum load
- 3 year warranty

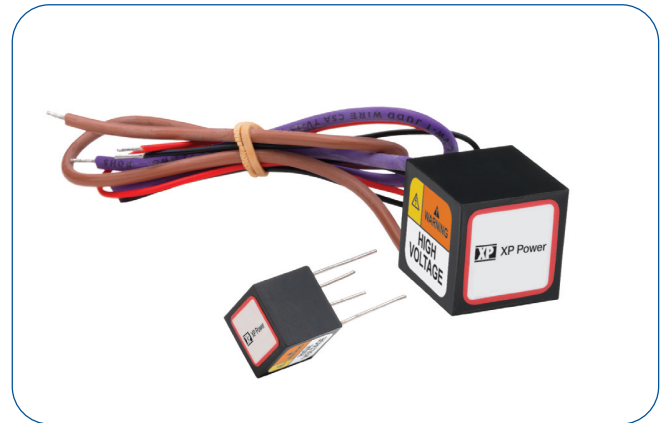

The Q Series is a broad line of ultra-miniature, high reliability DC to HV DC converters supplying up to 5,000 volts in only 0.125 cubic inches and up to 10,000 volts in only 0.614 cubic inches. Input voltage can be 5V, 12V, 15V, or 24V. The output is directly proportional to the input voltage and is linear from <0.7V input to maximum input voltage, allowing for an adjustable output voltage. Output is load dependent. Isolation permits <math>\pm 500V</math> bias on output return and output power is 0.5 watt.

No external components or minimum load are required. Variations include dual output (center-tap), a separate control pin, and an external shield. These component-sized converters operate over a wide temperature range making them ideal for portable, battery-powered equipment requiring minimal size and weight.

### Dimensions:

#### Q01 - Q50:

0.5 x 0.5 x 0.5" (12.7 x 12.7 x 12.7mm)

#### Q60 - Q80:

0.85 x 0.85 x 0.85" (21.6 x 21.6 x 21.6mm)

### Key Applications:

- Avalanche Photo Diodes
- Photo Multiplier Tubes
- Piezo Devices
- Sustaining Ion Pumps
- Electrophoresis
- Igniters
- Capacitor Charging

### Input

Characteristic	Minimum	Typical	Maximum	Units	Notes & Conditions
Input Voltage	0.7		5,12,15,24	VDC	See Models and Ratings Table.
Input Current			400	mA	See Models and Ratings Table.
Control Voltage Input (optional)	Analog Control Voltage adjusts output from 0 to 100%, not to exceed Input Voltage, see Application Notes.				

### Output

Characteristic	Minimum	Typical	Maximum	Units	Notes & Conditions
Output Voltage			10,000	VDC	See Models and Ratings Table
Output Current			5	mA	See Models and Ratings Table
Output Voltage Tolerance		+10, -10		%	At Max Vout, Full Load, Measured from pin 3 to pin 4
Minimum Load	No minimum load required				
Regulation	Unregulated, Output is proportional to Input. See Application Notes.				
Short Circuit Protection	1			minute	
Ripple and Noise	0.1		1	%	See Models and Ratings Table.

### Notes

1. Maximum output current is available at maximum rated output voltage, and derates linearly as input voltage is decreased.
2. Output Voltage is load dependent. Under light or no-load conditions, reduce the Input Voltage so maximum rated Output Voltage is not exceeded.
3. Specifications are after 30 minute warm-up, full-load at 25°C, unless otherwise noted.

4. Proper thermal management techniques are required to maintain safe case temperature at maximum power output.
5. See Application Notes for connection diagrams, page 8.
6. All orderable part numbers are listed on pages 3 and 4.

### Environmental

Characteristic	Minimum	Typical	Maximum	Units	Notes & Conditions
Operating Temperature (case)	-25		+70	°C	Q01 to Q20, standard operating temp
Operating Temperature (case)	-55		+75	°C	Q01 to Q20, extended operating temp
Operating Temperature (case)	-25		+60	°C	Q25 to Q50, standard operating temp
Operating Temperature (case)	-55		+70	°C	Q25 to Q50, extended operating temp
Operating Temperature (case)	-10		+60	°C	Q60 to Q101, standard operating temp
Storage Temperature	-55		+105	°C	Q01 to Q50
Storage Temperature	-20		+105	°C	Q60 to Q101
Humidity			95	%RH	Non-condensing
Cooling					Natural Convection

### Safety Approvals

Safety Agency	Safety Standard	Notes & Conditions
UL	IEC/UL/CSA/EN 62368	
CE	CE Directive, RoHs and LVD	Where applicable
RoHS	RoHS 2 and 3 Directive (2011/65/EU)	Where applicable

### General

Characteristic	Minimum	Typical	Maximum	Units	Notes & Conditions
Isolation: Input to Output			500	V	< ±500 VDC Bias on Output Return
Leakage Current			250	nA	
Switching Frequency	75		500	kHz	
Construction	Solid vacuum encapsulation, UL 94 V-0 rated.				
Mean Time Between Failure	3			MHrs	Per Bellcore TR 332

### Copper Shield Placement

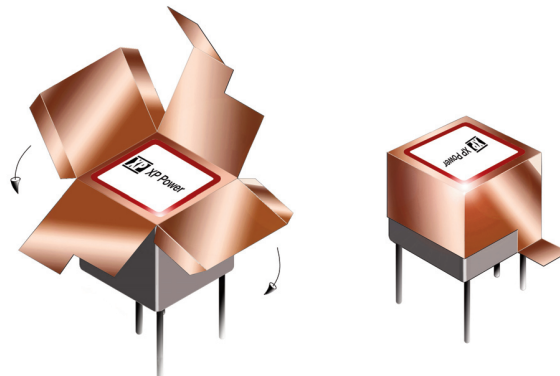

### Block Diagram

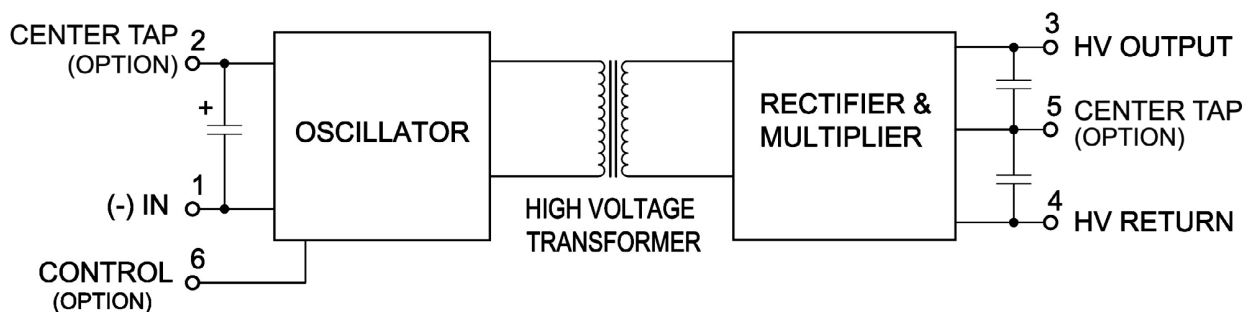

Models & Ratings

OUTPUT				INPUT			Model Number
Output Voltage <sup>(2)</sup>	Output Current <sup>(1)</sup>	Ripple	Polarity <sup>(5)</sup>	Input Voltage	Input Current, No Load	Input Current, Full Load	
0 to 100V	5.00mA	<1.0%	Reversible	5V	<100mA	<250mA	Q01-5
0 to 100V	5.00mA	<1.0%	Reversible	5V	<100mA	<250mA	Q01-5C
0 to +/-50V	5.00mA	<1.0%	Dual	5V	<100mA	<250mA	Q01CT-5
0 to 100V	5.00mA	<1.0%	Reversible	12V	<40mA	<100mA	Q01-12
0 to 100V	5.00mA	<1.0%	Reversible	12V	<40mA	<100mA	Q01-12CT
0 to 100V	5.00mA	<1.0%	Reversible	12V	<40mA	<100mA	Q01-12S
0 to +/-50V	5.00mA	<1.0%	Dual	12V	<40mA	<100mA	Q01CT-12TS
0 to 100V	5.00mA	<1.0%	Reversible	24V	<20mA	<50mA	Q01-24
0 to 150V	3.33mA	<0.50%	Reversible	5V	<100mA	<250mA	Q015-5
0 to 150V	3.33mA	<0.50%	Reversible	5V	<100mA	<250mA	Q015-5TS
0 to 150V	3.33mA	<0.50%	Reversible	12V	<40mA	<100mA	Q015-12CTRS
0 to 150V	3.33mA	<0.50%	Reversible	12V	<40mA	<100mA	Q015-12C
0 to 200V	2.50mA	<0.25%	Reversible	5V	<100mA	<250mA	Q02-5
0 to 200V	2.50mA	<0.25%	Reversible	5V	<100mA	<250mA	Q02-5CS
0 to 200V	2.50mA	<0.25%	Reversible	5V	<100mA	<250mA	Q02-5CTS
0 to 200V	2.50mA	<0.25%	Reversible	5V	<100mA	<250mA	Q02-5TR
0 to 200V	2.50mA	<0.25%	Reversible	12V	<40mA	<100mA	Q02-12
0 to 200V	2.50mA	<0.25%	Reversible	12V	<40mA	<100mA	Q02-12CTS
0 to 200V	2.50mA	<0.25%	Reversible	24V	<20mA	<50mA	Q02-24
0 to +/-100V	2.50mA	<0.25%	Dual	24V	<20mA	<50mA	Q02CT-24R
0 to 250V	2.00mA	<0.25%	Reversible	5V	<100mA	<250mA	Q025-5
0 to 250V	2.00mA	<0.25%	Reversible	5V	<100mA	<250mA	Q025-5C
0 to 250V	2.00mA	<0.25%	Reversible	5V	<100mA	<250mA	Q025-5RS
0 to 250V	2.00mA	<0.25%	Reversible	12V	<40mA	<100mA	Q025-12
0 to 300V	1.67mA	<0.25%	Reversible	5V	<100mA	<250mA	Q03-5
0 to 300V	1.67mA	<0.25%	Reversible	12V	<40mA	<100mA	Q03-12
0 to 400V	1.25mA	<0.10%	Reversible	5V	<100mA	<250mA	Q04-5
0 to 400V	1.25mA	<0.10%	Reversible	5V	<100mA	<250mA	Q04-5RS
0 to +/-200V	1.25mA	<0.10%	Dual	5V	<100mA	<250mA	Q04CT-5
0 to 400V	1.25mA	<0.10%	Reversible	12V	<40mA	<100mA	Q04-12
0 to +/-200V	1.25mA	<0.10%	Dual	12V	<40mA	<100mA	Q04CT-12
0 to 400V	1.25mA	<0.10%	Reversible	24V	<20mA	<50mA	Q04-24
0 to 400V	1.25mA	<0.10%	Reversible	24V	<20mA	<50mA	Q04-24TR
0 to 450V	1.11mA	<0.15%	Reversible	12V	<40mA	<100mA	Q045-12
0 to 500V	1.00mA	<0.15%	Reversible	5V	<100mA	<250mA	Q05-5
0 to 500V	1.00mA	<0.15%	Reversible	5V	<100mA	<250mA	Q05-5C
0 to 500V	1.00mA	<0.15%	Reversible	5V	<100mA	<250mA	Q05-5CTRS
0 to 500V	1.00mA	<0.15%	Reversible	5V	<100mA	<250mA	Q05-5RS
0 to 500V	1.00mA	<0.15%	Reversible	12V	<40mA	<100mA	Q05-12
0 to 500V	1.00mA	<0.15%	Reversible	12V	<40mA	<100mA	Q05-12T
0 to 500V	1.00mA	<0.15%	Reversible	15V	<32mA	<80mA	Q05-15
0 to 500V	1.00mA	<0.15%	Reversible	24V	<20mA	<50mA	Q05-24
0 to 500V	1.00mA	<0.15%	Reversible	24V	<20mA	<50mA	Q05-24CRS
0 to 500V	1.00mA	<0.15%	Reversible	24V	<20mA	<50mA	Q05-24CTS
0 to 600V	833uA	<0.10%	Reversible	5V	<100mA	<250mA	Q06-5
0 to 600V	833uA	<0.10%	Reversible	12V	<40mA	<100mA	Q06-12
0 to 600V	833uA	<0.10%	Reversible	15V	<32mA	<80mA	Q06-15
0 to 600V	833uA	<0.10%	Reversible	24V	<20mA	<50mA	Q06-24
0 to 700V	714uA	<0.25%	Reversible	5V	<100mA	<250mA	Q07-5
0 to 700V	714uA	<0.25%	Reversible	12V	<40mA	<100mA	Q07-12
0 to 700V	714uA	<0.25%	Reversible	15V	<32mA	<80mA	Q07-15
0 to 800V	625uA	<0.30%	Reversible	24V	<20mA	<50mA	Q08-24
0 to 900V	556uA	<0.25%	Reversible	12V	<40mA	<100mA	Q09-12
0 to 900V	556uA	<0.25%	Reversible	12V	<40mA	<100mA	Q09-12C
0 to 900V	556uA	<0.25%	Reversible	12V	<40mA	<100mA	Q09-12T
0 to +/-450V	556uA	<0.25%	Dual	12V	<40mA	<100mA	Q09CT-12
0 to 900V	556uA	<0.25%	Reversible	24V	<20mA	<50mA	Q09-24R
0 to +1000V	500uA	<0.25%	Positive	5V	<100mA	<250mA	Q10-5
0 to +1000V	500uA	<0.25%	Positive	5V	<100mA	<250mA	Q10-5RS
0 to +1000V	500uA	<0.25%	Positive	5V	<100mA	<250mA	Q10-5CTS
0 to +1000V	500uA	<0.25%	Positive	5V	<100mA	<250mA	Q10-5TS
0 to -1000V	500uA	<0.25%	Negative	5V	<100mA	<250mA	Q10N-5
0 to -1000V	500uA	<0.25%	Negative	5V	<100mA	<250mA	Q10N-5C
0 to -1000V	500uA	<0.25%	Negative	5V	<100mA	<250mA	Q10N-5CS
0 to -1000V	500uA	<0.25%	Negative	5V	<100mA	<250mA	Q10N-5S

**Models & Ratings**

OUTPUT				INPUT			Model Number
Output Voltage <sup>(2)</sup>	Output Current <sup>(1)</sup>	Ripple	Polarity <sup>(5)</sup>	Input Voltage	Input Current, No Load	Input Current, Full Load	
0 to +1000V	500uA	<0.25%	Positive	12V	<40mA	<100mA	Q10-12
0 to +1000V	500uA	<0.25%	Positive	12V	<40mA	<100mA	Q10-12CTS
0 to -1000V	500uA	<0.25%	Negative	12V	<40mA	<100mA	Q10N-12
0 to +1000V	500uA	<0.25%	Positive	24V	<20mA	<50mA	Q10-24R
0 to +1200V	417uA	<0.25%	Positive	5V	<100mA	<250mA	Q12-5
0 to +1200V	417uA	<0.25%	Positive	5V	<100mA	<250mA	Q12-5R
0 to +1200V	417uA	<0.25%	Positive	5V	<100mA	<250mA	Q12-5RS
0 to +1200V	417uA	<0.25%	Positive	5V	<100mA	<250mA	Q12-5TS
0 to -1200V	417uA	<0.25%	Negative	5V	<100mA	<250mA	Q12N-5
0 to -1200V	417uA	<0.25%	Negative	5V	<100mA	<250mA	Q12N-5RS
0 to -1200V	417uA	<0.25%	Negative	5V	<100mA	<250mA	Q12N-5TS
0 to +1200V	417uA	<0.25%	Positive	12V	<40mA	<100mA	Q12-12
0 to -1200V	417uA	<0.25%	Negative	12V	<40mA	<100mA	Q12N-12
0 to -1200V	417uA	<0.25%	Negative	15V	<32mA	<80mA	Q12N-15
0 to -1200V	417uA	<0.25%	Negative	24V	<20mA	<50mA	Q12N-24C
0 to +1500V	333uA	<0.25%	Positive	5V	<100mA	<250mA	Q15-5
0 to +1500V	333uA	<0.25%	Positive	5V	<100mA	<250mA	Q15-5S
0 to -1500V	333uA	<0.25%	Negative	5V	<100mA	<250mA	Q15N-5
0 to -1500V	333uA	<0.25%	Negative	5V	<100mA	<250mA	Q15N-5S
0 to -1500V	333uA	<0.25%	Negative	5V	<100mA	<250mA	Q15N-5T
0 to +1500V	333uA	<0.25%	Positive	12V	<40mA	<100mA	Q15-12
0 to +1500V	333uA	<0.25%	Positive	12V	<40mA	<100mA	Q15-12C
0 to +1500V	333uA	<0.25%	Positive	12V	<40mA	<100mA	Q15-12S
0 to +1500V	333uA	<0.25%	Positive	12V	<40mA	<100mA	Q15-12T
0 to +1500V	333uA	<0.25%	Positive	12V	<40mA	<100mA	Q15-12TS
0 to -1500V	333uA	<0.25%	Negative	12V	<40mA	<100mA	Q15N-12C
0 to +1500V	333uA	<0.25%	Positive	24V	<20mA	<50mA	Q15-24
0 to -1500V	333uA	<0.25%	Negative	24V	<20mA	<50mA	Q15N-24
0 to +2000V	250uA	<0.25%	Positive	5V	<100mA	<250mA	Q20-5
0 to +2000V	250uA	<0.25%	Positive	5V	<100mA	<250mA	Q20-5RS
0 to +2000V	250uA	<0.25%	Positive	5V	<100mA	<250mA	Q20-5TR
0 to -2000V	250uA	<0.25%	Negative	5V	<100mA	<250mA	Q20N-5
0 to +2000V	250uA	<0.25%	Positive	12V	<40mA	<100mA	Q20-12
0 to -2000V	250uA	<0.25%	Negative	12V	<40mA	<100mA	Q20N-12
0 to +2000V	250uA	<0.25%	Positive	24V	<20mA	<50mA	Q20-24
0 to +2500V	200uA	<0.50%	Positive	5V	<250mA	<400mA	Q25-5
0 to +2500V	200uA	<0.50%	Positive	5V	<250mA	<400mA	Q25-5T
0 to -2500V	200uA	<0.50%	Negative	5V	<250mA	<400mA	Q25N-5TR
0 to +2500V	200uA	<0.50%	Positive	12V	<100mA	<250mA	Q25-12TR
0 to +2500V	200uA	<0.50%	Positive	24V	<35mA	<75mA	Q25-24
0 to +3000V	167uA	<0.50%	Positive	5V	<250mA	<400mA	Q30-5
0 to -3000V	167uA	<0.50%	Negative	5V	<250mA	<400mA	Q30N-5
0 to +3000V	167uA	<0.50%	Positive	12V	<100mA	<250mA	Q30-12
0 to -3000V	167uA	<0.50%	Negative	12V	<100mA	<250mA	Q30N-12
0 to +3000V	167uA	<0.50%	Positive	24V	<35mA	<75mA	Q30-24R
0 to -3000V	167uA	<0.50%	Negative	24V	<35mA	<75mA	Q30N-24R
0 to +4000V	125uA	<0.50%	Positive	5V	<250mA	<400mA	Q40-5
0 to -4000V	125uA	<0.50%	Negative	5V	<250mA	<400mA	Q40N-5
0 to -4000V	125uA	<0.50%	Negative	5V	<250mA	<400mA	Q40N-5T
0 to +4000V	125uA	<0.50%	Positive	12V	<100mA	<250mA	Q40-12
0 to +5000V	100uA	<0.50%	Positive	5V	<250mA	<400mA	Q50-5
0 to +5000V	100uA	<0.50%	Positive	5V	<250mA	<400mA	Q50-5C
0 to +5000V	100uA	<0.50%	Positive	5V	<250mA	<400mA	Q50-5CTS
0 to -5000V	100uA	<0.50%	Negative	5V	<250mA	<400mA	Q50N-5
0 to -5000V	100uA	<0.50%	Negative	5V	<250mA	<400mA	Q50N-5T
0 to +6000V	83.3uA	<1.0%	Positive	5V	<175mA	<250mA	Q60-5
0 to +6000V	83.3uA	<1.0%	Positive	5V	<175mA	<250mA	Q60-5S
0 to -6000V	83.3uA	<1.0%	Negative	5V	<175mA	<250mA	Q60N-5
0 to +8000V	62.5uA	<1.0%	Positive	5V	<175mA	<250mA	Q80-5
0 to +10,000V	50.0uA	<1.0%	Positive	5V	<175mA	<250mA	Q101-5
0 to -10,000V	50.0uA	<1.0%	Negative	5V	<175mA	<250mA	Q101N-5
0 to -10,000V	50.0uA	<1.0%	Negative	5V	<175mA	<250mA	Q101N-5RS

**Option Codes**

Code	Meaning	Code	Meaning
CT-	Center Tap, Dual Output	-S	External Copper Shield
-C	Control Pin	-R	RoHS Designator for Legacy Model
-T	Extended Operating Temperature		

Mechanical Details

Q01-Q20

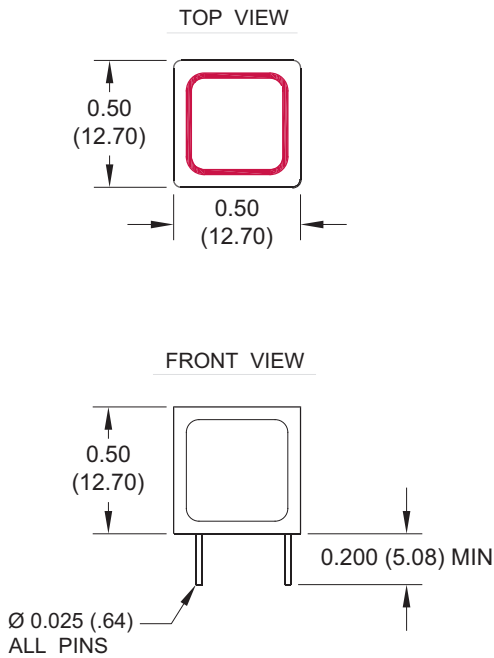

PCB Layout

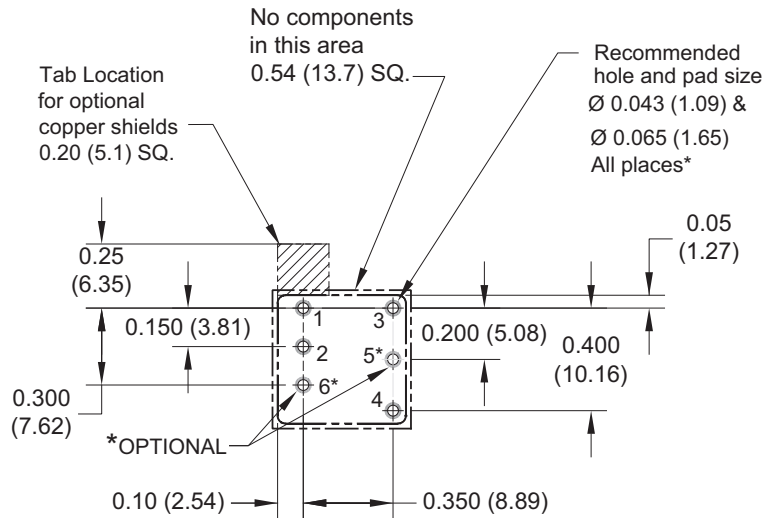

PIN #	Q01-Q09	Q10-Q20	Q25-Q50
1	INPUT (-)	INPUT (-)	INPUT (-)
2	INPUT (+)	INPUT (+)	INPUT (+)
3	OUTPUT (+)	HV OUTPUT	HV OUTPUT
4	OUTPUT (-)	HV RETURN	HV RETURN
5*	CENTER TAP		
6*	CONTROL PIN		

\*Pins 5 & 6 are optional

Q25-Q50

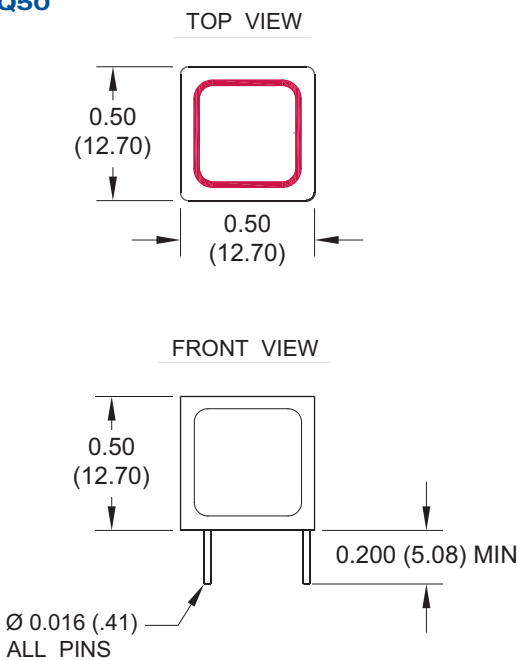

PCB Layout

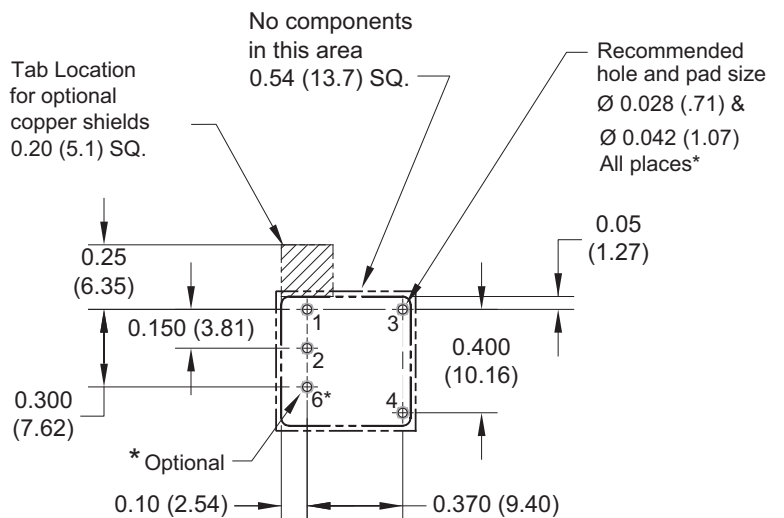

Notes

All dimensions are in inches (mm)  
Weight Q01-Q50: 0.15oz (4.25g).

Tolerance: X.XX±0.02 (0.51)  
Pin Tolerance: ±0.005 (0.127)

**Mechanical Details**

**Q60-Q101**

WIRE	COLOR	FUNCTION
1	RED	INPUT (+)
2	BLACK	INPUT (-)
3	BROWN	HV OUTPUT
4	VIOLET	HV RETURN

**Notes**

All dimensions are in inches (mm)  
 Weight: 1oz (28.3g)  
 Tolerance: X.XX±0.02 (0.51)  
 Pin Tolerance: ±0.005 (0.127)

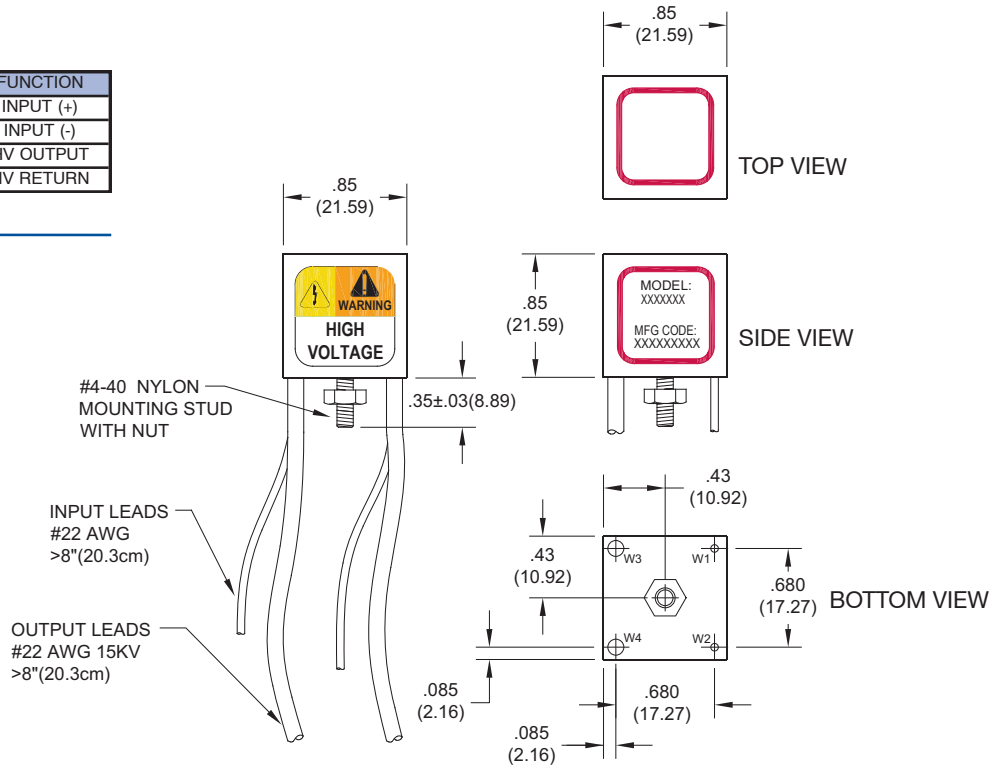

**Application Notes**

**Typical HV Output vs. Control Voltage**

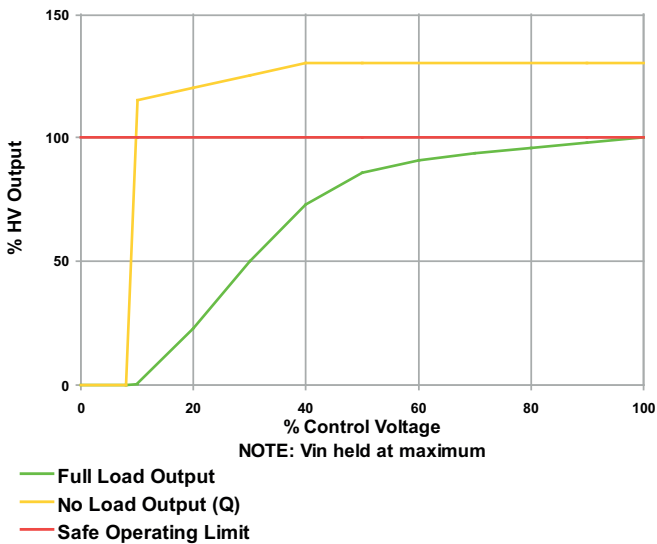

**Typical Output vs Input Voltage**

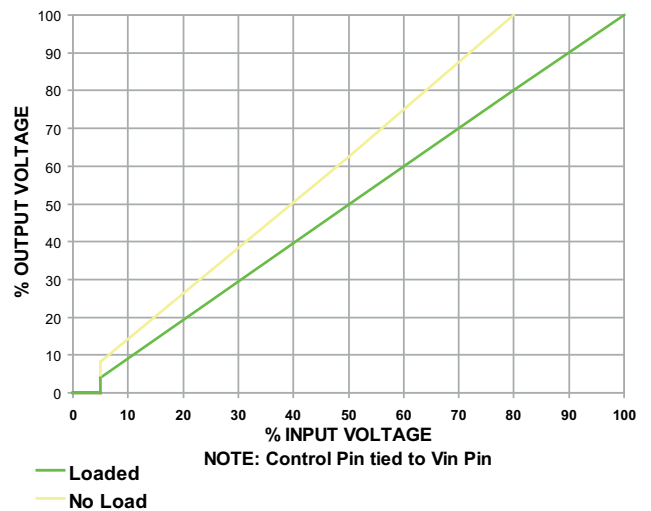

\*For more details, our website has an Application Note - Design Considerations for the Q Series.

Connection Diagram

Q01-Q09 - positive output for reversible models

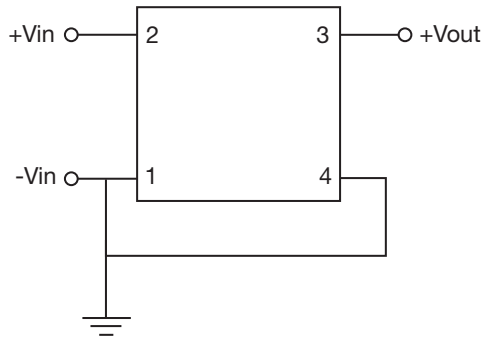

Q01-Q09 - negative output for reversible models

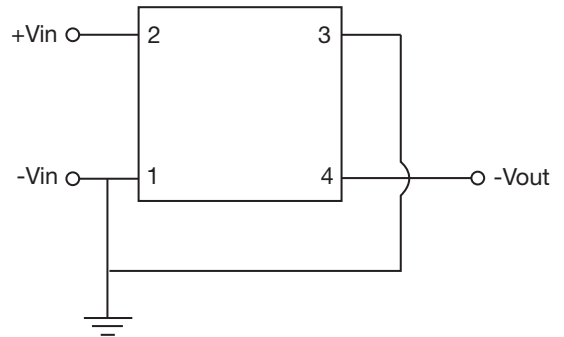

Q01CT-Q09CT - dual output

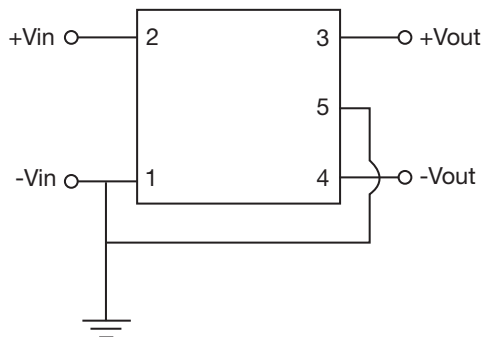

Q10-Q101 - output is positive or negative by model number

