

# PMH

## Highlights & Features

- Household appliance approvals IEC/EN 60335-1, IEC/EN 61558-1 and IEC/EN 61558-2-16
- Universal AC input voltage
- Full power from -20°C to +50°C operation @ 5000 m or 16400 ft. altitude
- Full corrosion resistant aluminium casing
- High MTBF > 700,000 hrs as per Telcordia SR-332
- Versatile connector options available: Harness connectors
- Certified according to IEC/EN/UL 62368-1



## Safety Standards



CB Certified for worldwide use

**Model Number:** PMH-24V50WCA□  
**Unit Weight:** 0.21 kg (0.46 lb)  
**Dimensions (L x W x H):** 98 x 97 x 38 mm  
 (3.86 x 3.82 x 1.50 inch)

## General Description

The PMH-24V50WCA□ offers universal input from 85 Vac to 264 Vac with nominal output voltage of 24 V. The highly efficient convection cooling construction can operate from -30°C to 70°C. The PMH series is specifically designed for household electrical appliances with safety approvals including IEC/EN 60335-1 and IEC/EN 61558-2-16, as well as IEC/EN/UL 60950-1 and IEC/EN/UL 62368-1. In addition, the product meets the EMC approvals to EN/BS EN 55014-1 / EN/BS EN 55014-2 for household appliances and EN/BS EN 61000-6-1 / EN/BS EN 61000-6-3 for residential environment without extra EMI filter required and comes with several connector options consisting of Terminal Block and Harness connectors. Other available options include isolation or non-isolation between Primary Earth and output DC Return (-V pins on output connector).

## Model Information

PMH Panel Mount Power Supply

Model Number	Input Voltage Range	Rated Output Voltage	Rated Output Current
PMH-24V50WCA□	85-264 Vac (120-375 Vdc)	24 Vdc	2.10 A

## Model Numbering

PM	H –	24 V	50 W	C	A	□
Panel Mount	Product Type H – Household Series	Output Voltage	Output Power	Package Type C – Enclosed	No PFC	Connector Type and Primary Earth to Output DC Return Connection. See options in table below



A, S



H, T

Connector Type	Output non-isolated to PE	Output isolated to PE
Terminal Block	A	S
Harness*	H	T

\*Options

## Specifications

### Input Ratings / Characteristics

Nominal Input Voltage	100-240 Vac	
Input Voltage Range	85-264 Vac	
Nominal Input Frequency	50-60 Hz	
Input Frequency Range	47-63 Hz	
Nominal DC Input Voltage	125-250 Vdc	
DC Input Voltage Range	120-375 Vdc	
Input Current	< 0.94 A @ 115 Vac, < 0.59 A @ 230 Vac	
Efficiency at 100% Load	> 87.0% @ 115 Vac, > 88.0% 230 Vac	
Max Power Dissipation	0% load	< 0.2W @ 115Vac, < 0.3W @ 230Vac
	100% load	< 7.4W @ 115Vac, < 6.8W @ 230Vac
Max Inrush Current (Cold Start)	< 35 A @ 115 Vac, < 70 A @ 230 Vac	
Leakage Current	< 0.5 mA @ 264 Vac	

### Output Ratings / Characteristics\*

Nominal Output Voltage	24 Vdc
Factory Set Point Tolerance	24 Vdc $\pm$ 2%
Output Voltage Adjustment Range	22-28 Vdc
Output Current	2.10 A (50 W max.)
Output Power	50 W
Line Regulation	< 0.5% (@ 85-264 Vac input, 100% load)
Load Regulation	< 0.5% (@ 85-264 Vac input, 0-100% load)
PARD** (20MHz)	< 100 mVpp @ -20°C to 70°C < 150 mVpp @ < -20°C to -30°C
Rise Time	< 20 ms @ nominal input (100% load)
Start-up Time	< 800 ms @ nominal input (100% load)
Hold-up Time	> 15 ms @ 115 Vac, > 90 ms @ 230 Vac (100% load)
Dynamic Response (Overshoot & Undershoot O/P Voltage)	$\pm$ 5% @ 85-264 Vac input, 0-100% load (Slew Rate: 0.1 A/ $\mu$ S, 50% duty cycle @ 5 Hz to 100 Hz)
Start-up with Capacitive Loads	8,000 $\mu$ F Max (@ > -20°C, 85-264 Vac input & @ $\leq$ -20°C, 100-264 Vac)

\*For power de-rating from < -20°C to -30°C, and 50°C to 70°C, see power de-rating on page 3.

\*\*PARD is measured with an AC coupling mode, 5 cm wires, and in parallel with 0.1  $\mu$ F ceramic capacitor & 47  $\mu$ F electrolytic capacitor.

### Mechanical

Case Chassis / Cover		Aluminium
Dimensions (L x W x H)		98 x 97 x 38 mm (3.86 x 3.82 x 1.50 inch)
Unit Weight		0.21 kg (0.46 lb)
Indicator	Green LED	DC OK
Cooling System		Convection
Terminal	PMH-24V50WCAA(S)	M3.5 x 5 Pins (Rated 300 V/15 A)
	PMH-24V50WCAH(I)	Input: B3P(6-2.3.5)-VH(LF)(SN) Output: B2P3-VH(LF)(SN)
Wire	PMH-24V50WCAA(S)	AWG 20-14
	PMH-24V50WCAH(I)	AWG 20-18
Noise (1 Meter from power supply)		Sound Pressure Level (SPL) < 25 dBA

### Environment

Surrounding Air Temperature	Operating	-30°C to +70°C
	Storage	-30°C to +85°C
Power De-rating		-20°C to -30°C de-rate power by 2.0% / °C > 50°C de-rate power by 2.5% / °C
Operating Humidity		5 to 95% RH (Non-Condensing)
Operating Altitude		0 to 5,000 Meters (16,400 ft.)
Shock Test	Non-Operating	IEC 60068-2-27, 30 G (300 m/S <sup>2</sup> ) for a duration of 18 ms, 1 times per direction, 2 times in total
Vibration	Non-Operating	IEC 60068-2-6, 10 Hz to 150 Hz @ 50 m/S <sup>2</sup> (5G peak); displacement of 0.35mm; 20 min per axis for all X, Y, Z direction
Over Voltage Category		II
Pollution Degree		2

### Protections

Overvoltage	28.8-35.2 V range, Hiccup Mode, Non-Latching (Auto-Recovery)
Overload / Overcurrent	> 120% of rated load current, Hiccup Mode, Non-Latching (Auto-Recovery)
Over Temperature	< 75°C Ambient Temp @ 100% load, Non-Latching (Auto-Recovery)
Short Circuit	Hiccup Mode, Non-Latching (Auto-recovery when the fault is removed).
Internal Fuse at L pin	T3.15AH
Protection Against Shock	Class I with PE* connection

\*PE: Primary Earth

### Reliability Data

MTBF	> 700,000 hrs, as per Telcordia SR-332 I/P: 115 Vac, O/P: 100% load, Ta: 25°C
Expected Cap Life Time	10 years (115 Vac & 230 Vac, 50% load @ 40°C)

### Safety Standards / Directives

Safety Entry Low Voltage	Output non-isolated to PE	PELV (EN 60335), SELV (IEC 60950)
	Output isolated to PE	SELV (EN 60335), SELV (IEC 60950)
Electrical Safety	SIQ Bauart	EN 60335-1, EN 61558-1, EN 61558-2-16, EN 62368-1
	UL/cUL recognized	UL 60950-1 and CSA C22.2 No. 60950-1 (File No. E191395) UL 62368-1 and CSA C22.2 No. 62368-1 (File No. E191395)
	CB scheme	IEC 60950-1, IEC 60335-1, IEC 61558-1, IEC 61558-2-16, IEC 62368-1
	UKCA	BS EN 62368-1
CE		In conformance with EMC Directive 2014/30/EU and Low Voltage Directive 2014/35/EU
UKCA		In conformance with Electrical Equipment (Safety) Regulations 2016 No. 1011 and The Electromagnetic Compatibility Regulations 2016 No. 1091
Galvanic Isolation	Input to Output	5.0 KVac
	Input to Ground	1.5 KVac
	Output to Ground	Output non-isolated to PE (common pins connect to PE) (PMH-24V50WCAA, PMH-24V50WCAH)  1.5 KVdc (Output isolated to PE) (PMH-24V50WCAS, PMH-24V50WCAT)

EMC

Emissions (CE & RE)		Generic Standards: CISPR 32, EN/BS EN 55032, EN/BS EN 55014-1, EN/BS EN 61000-6-3, FCC Title 47: Class B	
Immunity		Generic Standards: EN/BS EN 55024, EN/BS EN 61000-6-1, EN/BS EN 55014-2	
Electrostatic Discharge	IEC 61000-4-2	Level 4 Criteria A <sup>1)</sup> Air Discharge: 15 kV Contact Discharge: 8 kV	
Radiated Field	IEC 61000-4-3	Level 3 Criteria A <sup>1)</sup> 80 MHz - 1 GHz, 10 V/M with 1 kHz tone / 80% modulation 1.4 GHz - 2 GHz, 10 V/M with 1 kHz tone / 80% modulation 2 GHz - 2.7 GHz, 10 V/M with 1 kHz tone / 80% modulation	
Electrical Fast Transient / Burst	IEC 61000-4-4	Level 3 Criteria A <sup>1)</sup> 2 kV	
Surge	IEC 61000-4-5	Level 3 Criteria A <sup>1)</sup> Common Mode <sup>3)</sup> : 2 kV Differential Mode <sup>4)</sup> : 1 kV	
Conducted	IEC 61000-4-6	Level 3 Criteria A <sup>1)</sup> 150 kHz-80 MHz, 10 Vrms	
Power Frequency Magnetic Fields	IEC 61000-4-8	Criteria A <sup>1)</sup> 10 A/Meter	
Voltage Dips and Interruptions	IEC 61000-4-11	0% of 100 Vac, 20 ms 40% of 100 Vac, 200 ms 70% of 100 Vac, 500 ms 70% of 100 Vac, 600 ms 0% of 100 Vac, 6000 ms 0% of 240 Vac, 20 ms 40% of 240 Vac, 200 ms 70% of 240 Vac, 600 ms 0% of 240 Vac, 6000 ms	Criteria A <sup>1)</sup> Criteria A <sup>1)</sup> Criteria A <sup>1)</sup> Criteria B <sup>2)</sup> Criteria B <sup>2)</sup> Criteria A <sup>1)</sup> Criteria A <sup>1)</sup> Criteria A <sup>1)</sup> Criteria B <sup>2)</sup>
Low Energy Pulse Test (Ring Wave)	IEC 61000-4-12	Level 3 Criteria A <sup>1)</sup> Common Mode <sup>3)</sup> : 2 kV Differential Mode <sup>4)</sup> : 1 kV	
Voltage Fluctuation and Flicker		IEC/EN/BS EN 61000-3-3	

1) Criteria A: Normal performance within the specification limits  
2) Criteria B: Temporary degradation or loss of function which is self-recoverable  
3) Asymmetrical: Common mode (Line to earth)  
4) Symmetrical: Differential mode (Line to line)

**Block Diagram**

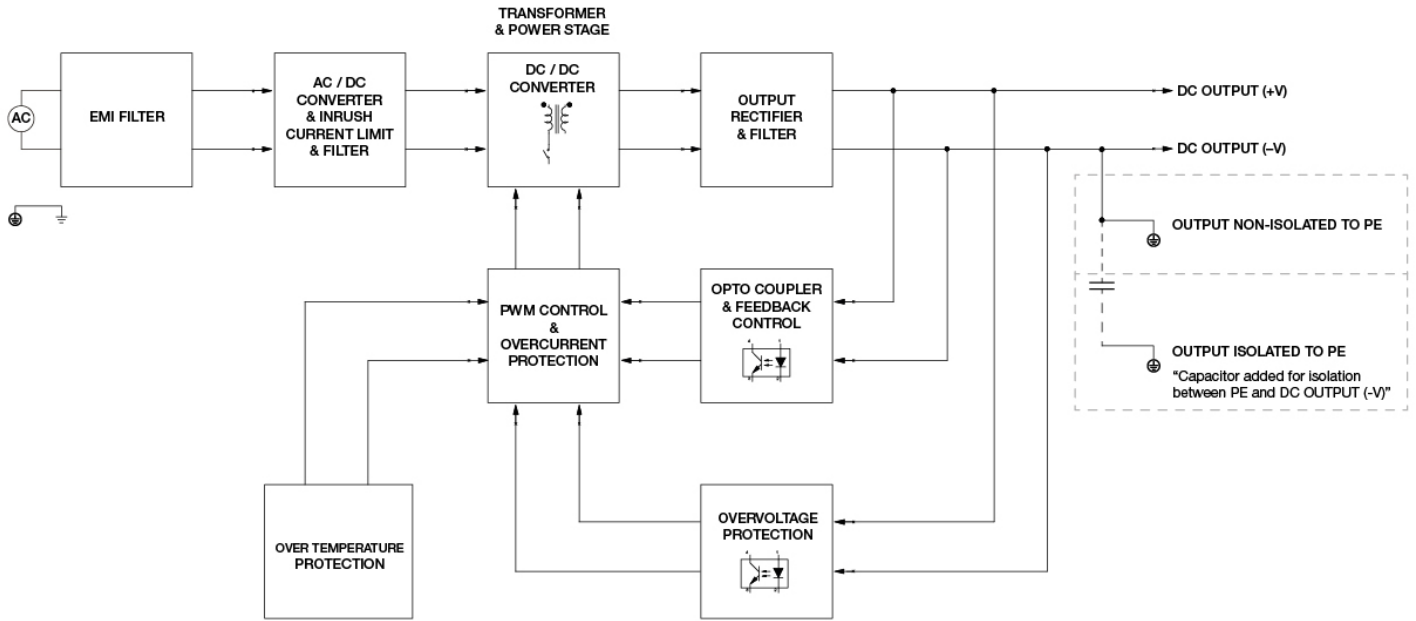

**Device Descriptions**

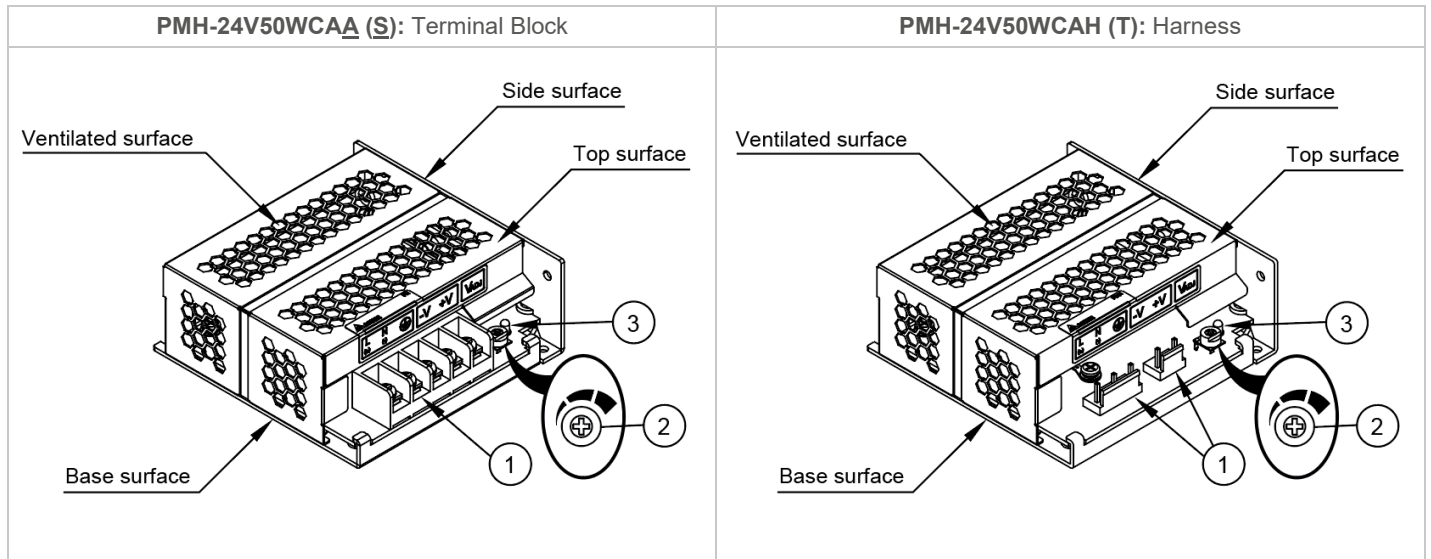

- 1) Input & Output terminal block connector
- 2) DC voltage adjustment potentiometer (22 V – 28 V)
- 3) DC OK control LED (Green)

Connector Type	Output non-isolated to PE	Output isolated to PE
Terminal Block	A	S
Harness	H	T

### Dimensions

L x W x H: 98 x 97 x 38 mm (3.86 x 3.82 x 1.50 inch) (PMH-24V50WCAA: Terminal Block)

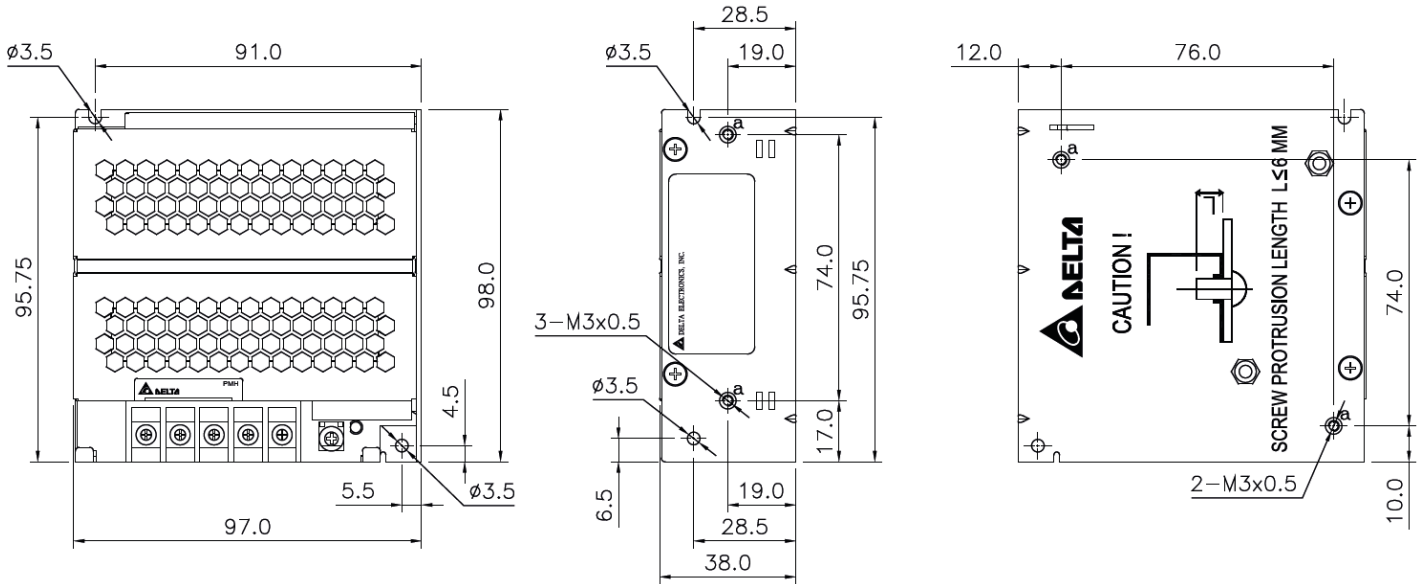

### Engineering Data

#### Output Load De-rating VS Surrounding Air Temperature

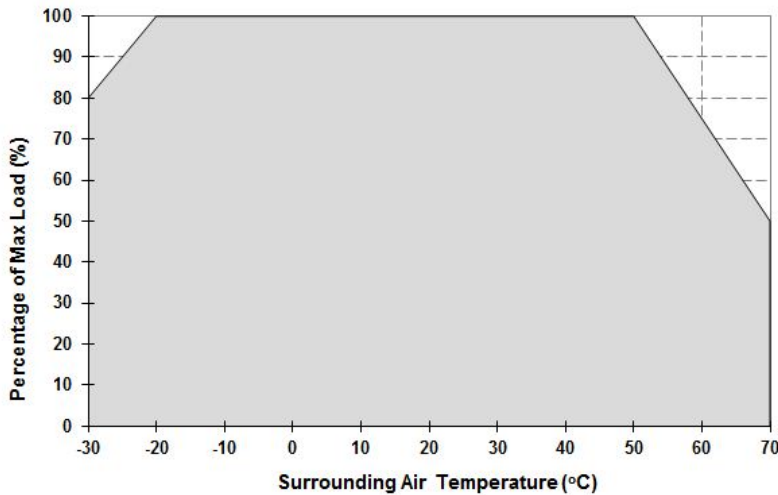
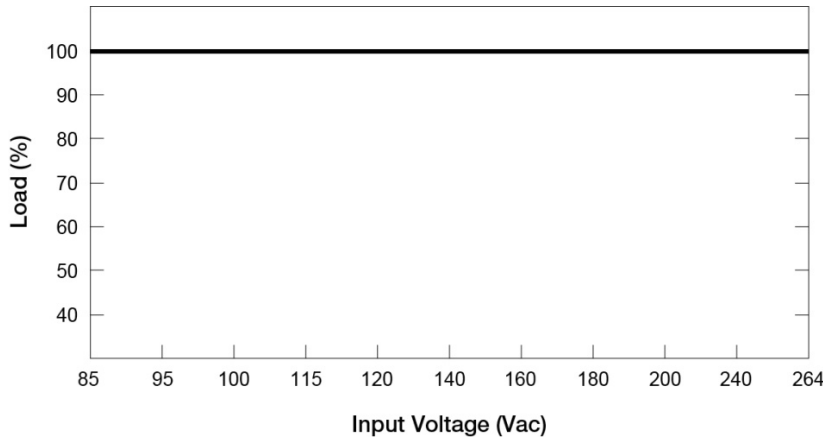

**Fig. 1 De-rating for Vertical and Horizontal Mounting Orientation**  
 -20°C to -30°C de-rate power by 2.0% / °C  
 > 50°C de-rate power by 2.5% / °C

#### Note

1. Power supply components may degrade, or be damaged, when the power supply is continuously used outside the shaded region, refer to the graph shown in Fig. 1.
2. If the output capacity is not reduced when surrounding air temperature exceeds its specification as defined on Page 3 under "Environment", the device will run into Over Temperature Protection. When activated, the output voltage will go into bouncing mode and will recover when the surrounding air temperature is lowered or the load is reduced as far as necessary to keep the device in working condition.
3. In order for the device to function in the manner intended, it is also necessary to keep a safety distance as recommended in the safety instructions while the device is in operation.
4. Depending on the surrounding air temperature and output load delivered by the power supply, the device can be very hot!
5. If the device has to be mounted in any other orientation, please contact [info@deltapsu.com](mailto:info@deltapsu.com) for more details.

### Output Load De-rating VS Input Voltage



■ No output power de-rating across the entire input voltage range

### Assembly & Installation

- Ⓐ Mounting holes for power supply assembly onto the mounting surface.  
The power supply shall be mounted on minimum 2 mounting holes using M3 screw minimum 5mm length.
- Ⓑ This surface belongs to customer's end system or panel where the power supply is mounted.
- Ⓒ Connector

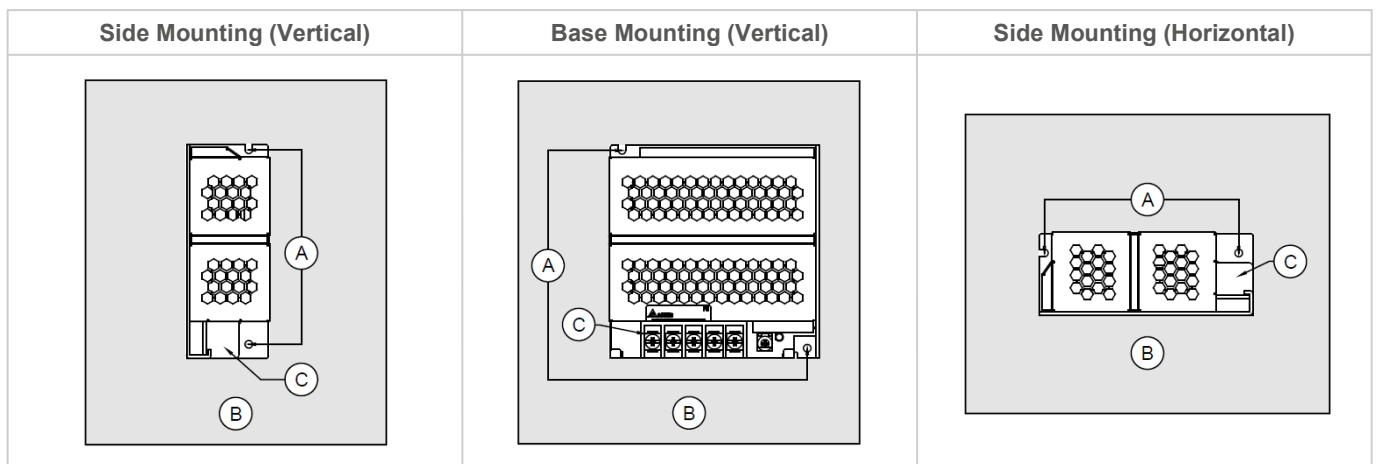

Fig. 2 Mounting Orientation

- Use flexible cable (stranded or solid) with the following sizes:

PMH-24V50WCAA (S)	PMH-24V50WCAH (T)
AWG 20-14	AWG 20-18

- The torque at the Connector shall not exceed 13 Kgf.cm (11.23 lbf.in). The insulation stripping length should not exceed 0.275" or 7 mm.



### Installation of Mounting Accessories

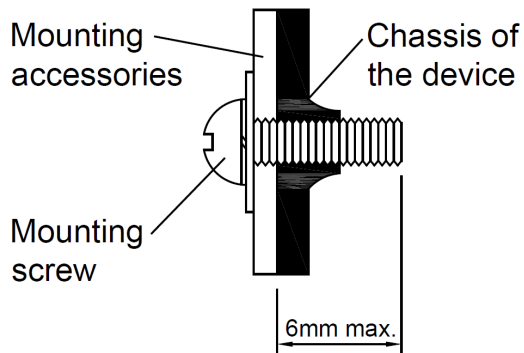

- Only use M3 screw  $\leq 6$  mm (0.23 inch) through the base mounting holes. This is to keep a safety distance between the screw and internal components.
- Recommended mounting tightening torque: 4~8 Kgf.cm (3.47~6.94 lbf.in).

### Safety Instructions

- To ensure sufficient convection cooling, always maintain a safety distance of  $\geq 20$  mm (0.78 inch) from all ventilated surfaces while the device is in operation.
- The device is not recommended to be placed on surface with low thermal conductivity, such as plastics, for example.
- Note that the enclosure of the device can become very hot depending on the ambient temperature and load of the power supply. Do not touch the device while it is in operation or immediately after power is turned OFF. Risk of burning!
- Do not touch the terminals while power is being supplied. Risk of electric shock.
- Prevent any foreign metal, particles or conductors from entering the device through the openings during installation. It may cause: Electric shock; Safety Hazard; Fire; Product failure
- The appliance is not to be used by persons (including children) with reduced physical, sensory or mental capabilities, or lack of experience and knowledge, unless they have been given supervision or instruction.
- Warning: When connecting the device, secure Earth connection before connecting L and N. When disconnecting the device, remove L and N connections before removing the Earth connection.
- The device is earthed and must be inaccessible.

## Functions

### Start-up Time

The time required for the output voltage to reach 90% of its final steady state set value, after the input voltage is applied.

### Rise Time

The time required for the output voltage to change from 10% to 90% of its final steady state set value.

### Hold-up Time

Time between the collapse of the AC input voltage, and the output falling to 95% of its steady state set value.

#### ■ Graph illustrating the Start-up Time, Rise Time, and Hold-up Time

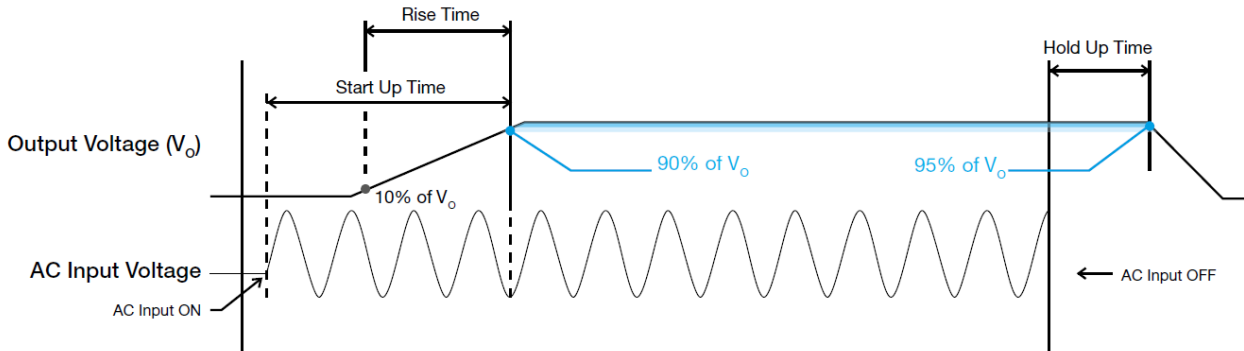

### Inrush Current

Inrush current is the peak, instantaneous, input current measured and, occurs when the input voltage is first applied. For AC input voltages, the maximum peak value of inrush current will occur during the first half cycle of the applied AC voltage. This peak value decreases exponentially during subsequent cycles of AC voltage.

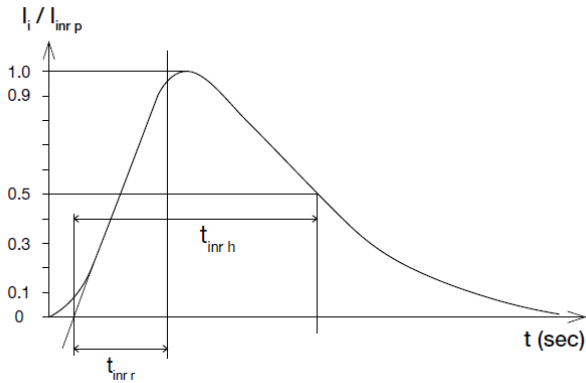

### Dynamic Response

The power supply output voltage will remain within  $\pm 5\%$  of its steady state value, when subjected to a dynamic load from 0% to 50%, 0% to 100% and 50% to 100% of its rated current.

#### ■ 50% duty cycle / 5 Hz to 1 kHz

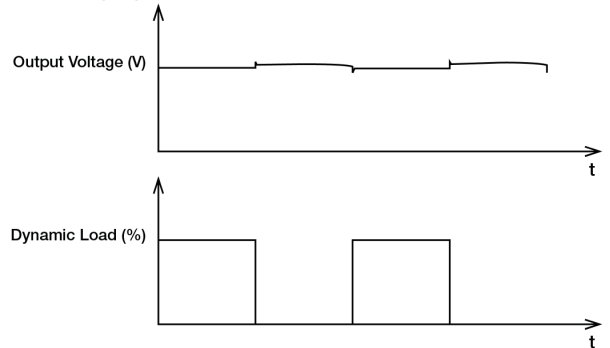

### Overload & Overcurrent Protections (Auto-Recovery)

The power supply's Overload (OLP) and Overcurrent (OCP) Protections will be activated when output current exceeds 120% of  $I_o$  (Max load). In such occurrence, the  $V_o$  will start to droop and once the power supply has reached its maximum power limit, the protection is activated and the power supply will go into "Hiccup mode" (Auto-Recovery). The power supply will recover once the fault condition of the OLP and OCP is removed and  $I_o$  is back within the specifications.

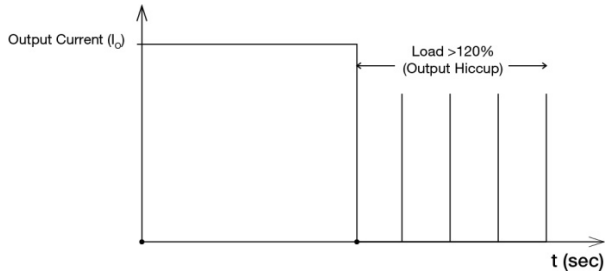

It is not recommended to prolong the duration of  $I_o$  when it is <120% but >100%, since it may cause damage to the PSU.

### Short Circuit Protection (Auto-Recovery)

The power supply's output OLP/OCP function also provides protection against short circuits. When a short circuit is applied, the output current will operate in "Hiccup mode", as shown in the illustration in the OLP/OCP section on this page. The power supply will return to normal operation after the short circuit is removed.

### Overvoltage Protection (Auto-Recovery)

The power supply's overvoltage circuit will be activated when its internal feedback circuit fails. The output voltage shall not exceed its specifications defined on Page 3 under "Protections".

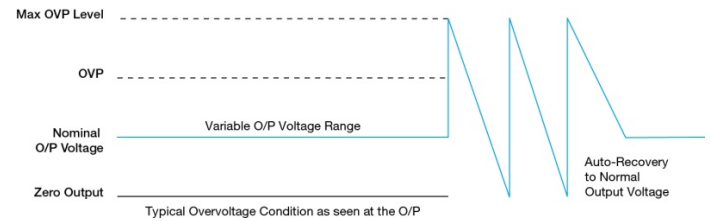

### Over Temperature Protection (Auto-Recovery)

As described in load de-rating section, the power supply also has Over Temperature Protection (OTP). In the event of a higher operating temperature at 100% load, the power supply will run into OTP when the operating temperature is beyond what is recommended in the de-rating graph. When activated, the output voltage will go into bouncing mode until the temperature drops to its normal operating temperature as recommended in the de-rating graph.

## Operating Mode

### ■ Redundant Operation

In order to ensure proper redundant operation for the power supply units (PSUs), the output voltage difference between the two units must be kept at 0.45~0.50 V for these 24V supplies. Follow simple steps given below to set them up for the redundant operation:

#### Step 1.

Measure output voltage of PSU 1 and PSU 2. If PSU 1 is the master unit, then  $V_o$  of PSU 1 must be higher than PSU 2. In order to set the output voltage, individually connect each power supply to 50% of rated load at any line voltage and set the PSU 1 and PSU 2 output voltage.

#### Step 2.

Connect the power supply units PSU 1 and PSU 2 to  $V_{in 1}$  &  $V_{in 2}$ , respectively, of the DRR-20N (or 20 A) module shown on the right of above diagram.

#### Step 3.

Connect the system load to  $V_{out}$ . Please note that output voltage  $V_{out}$  from DRR module will be =  $V_o$  (output voltage of power supply) –  $V_{drop}^*$  (in DRR module).

\* $V_{drop}$  will vary from 0.60 V to 0.90 V (Typical 0.65 V) depending on the load current and surrounding air temperature.

### ■ Parallel Operation

The power supply units (PSUs) can also be used for parallel operation in order to increase the output power. The difference in output voltage between the two units must be kept to within 25 mV of each other. This difference must be verified with the same output load connected independently to each unit.

Parameters such as EMI, inrush current, leakage current, PARD, start up time will be different from those on the datasheet, when two units are connected in parallel. The user will need to verify that any differences will still allow the two power supplies connected in parallel will work properly in their product/application.

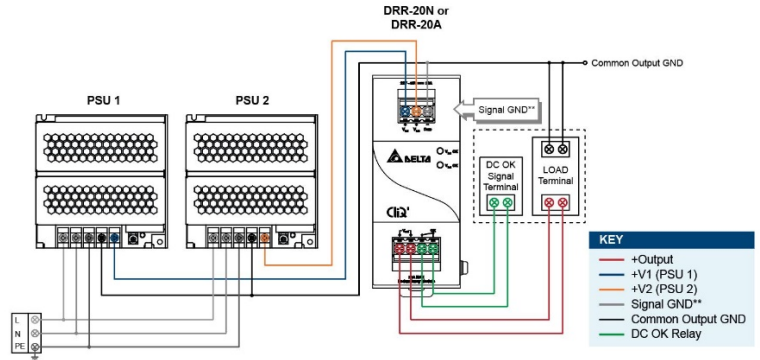

\*\*The Signal GND in the DRR module is for the built-in LED and DC OK signals. The Output GND terminals from the two PSU's do not need to be connected to the Signal GND terminal.

Fig. 3 Redundant Operation Connection Diagram

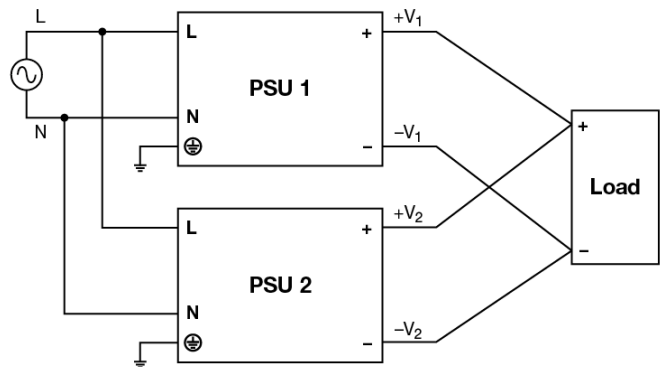

Fig. 4 Parallel Operation Connection Diagram

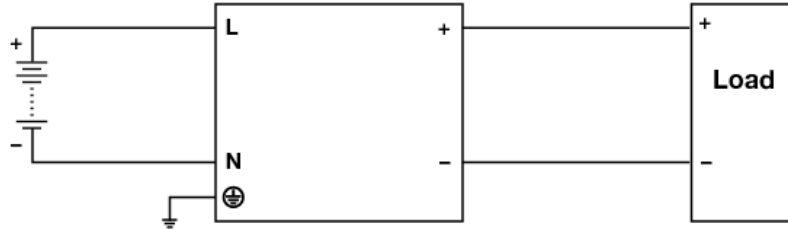

Fig. 5 DC Input Operation Connection Diagram

■ DC Input Operation

**Step 1.**

Use a battery or similar DC source.

**Step 2.**

Connect +pole to L and -pole to N.

**Step 3.**

Connect the PE terminal to an earth wire or to the machine ground.

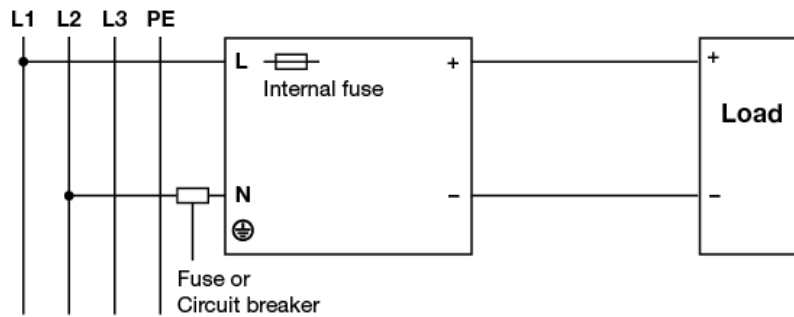

Fig. 6 2 of 3 Phase System Input Operation Connection Diagram

■ 2 of 3 Phase System Input Operation

Delta's PMH can use on 2 of 3 phase system. Please refer to the following step.

**Step 1.**

The input voltage applied from Line to Neutral is below the maximum rated input. The input voltage shall be below 240 Vac +10%.

**Step 2.**

The external protector is needed on N (Neutral) input line to secure a safety. N line does not have internal fuse protection. An appropriate fuse or circuit breaker should be connected in series with N input line connection like the following.

(April 2022, Rev. 08)