

PMF

Highlights & Features

- Universal AC input voltage range
- Built-in active PFC and automatic fan speed control
- Full corrosion resistant aluminium casing
- Conforms to harmonic current IEC/EN/BS EN 61000-3-2, Class A and Class D
- Cold start -20°C at 100% load (275 W)
- Remote ON/OFF is available as an option



Safety Standards



CB Certified for worldwide use

Model Number: PMF-5V320WC□□
Unit Weight: 0.86 kg (1.90 lb)
Dimensions (L x W x H): 215 x 115 x 50 mm
 (8.46 x 4.53 x 1.97 inch)

General Description

The PMF panel mount power supply series currently offers nominal output voltages of 5 V. These power supply units come with universal AC input from 85 Vac to 264 Vac and wide operating temperature of -10°C to +70°C. The built-in active PFC provides high power factor and conforms to harmonic current IEC/EN/BS EN 61000-3-2, Class A and Class D. This versatile series has two different connector options (Front Face and Terminal Block) to satisfy different application needs. Remote ON/OFF function is also available for the PMF series. All PMF power supplies conform to major international safety standards including IEC/EN/UL 62368-1 standards and are fully compliant with RoHS Directive for environmental protection.

Model Information

PMF Panel Mount Power Supply

Model Number	Input Voltage Range	Rated Output Voltage	Rated Output Current
PMF-5V320WC□□	85-264 Vac	5 Vdc	55.0 A

Model Numbering

						CC Code
PM	F –	5V	320W	C	□	□
Panel Mount	Product Series F – PFC Series	Output Voltage	Output Power (320 W series model)	Package Type C – Enclosed	Connector Type G – Front Face A – Terminal Block*	Variable B – No Remote ON/OFF R – With Remote ON/OFF*

*Options



G

A

Specifications

Input Ratings / Characteristics

Nominal Input Voltage	100-240 Vac	
Input Voltage Range	85-264 Vac	
Nominal Input Frequency	50-60 Hz	
Input Frequency Range	47-63 Hz	
Input Current	< 5.00 A @ 115 Vac, < 2.50 A @ 230 Vac	
Efficiency at 100% Load	78.5% typ. @ 230 Vac	
Max Power Dissipation	0% load	2.6 W typ. @ 115 Vac & 2.52 W typ. @ 230 Vac
	100% load	83.24 W typ. @ 115 Vac & 72.66 W typ. @ 230 Vac
Max Inrush Current (Cold Start)	< 30 A @ 115 Vac, < 50 A @ 230 Vac	
Power Factor at 100% load	0.98 typ. @ 115 Vac, 0.95 typ. @ 230 Vac	
Leakage Current	< 1 mA @ 240 Vac	

Output Ratings / Characteristics*

Nominal Output Voltage	5 Vdc	
Factory Set Point Tolerance	5 Vdc \pm 1%	
Output Voltage Adjustment Range	4.50-5.50 Vdc	
Output Current	0-55.0 A (275 W max.)	
Output Power	275 W	
Line Regulation	\pm 0.5% typ. (@ 115 Vac & 230 Vac)	
Load Regulation	\pm 2.0% typ. (@ 115 Vac & 230 Vac)	
PARD** (20 MHz)	< 150 mVpp @ 25°C	
	< 300 mVpp @ -10°C	
Rise Time	50 ms typ. @ 115 Vac & 230 Vac (100% load)	
Start-up Time	2500 ms typ. @ 115 Vac,	
	1000 ms typ. @ 230 Vac (100% load)	
Hold-up Time	16 ms typ. @ 115 Vac & 230 Vac (100% load)	
Dynamic Response (Overshoot & Undershoot O/P Voltage)	\pm 5% (0.5 V pk-pk) @ 115 Vac & 230 Vac, 0-50% load and 50-100% load (Slew Rate: 0.1 A/ μ S, 50% duty cycle @ 5 Hz)	
Start-up with Capacitive Loads	8,000 μ F Max	
Remote ON/OFF Function (Option)	CN102	Output ON: 5-12.5 V Output OFF: 0-0.5 V (For more information, please refer to the details in the Functional Manual section on Page 11)

*For power de-rating from 50°C to 70°C, see power de-rating on page 3.

**PARD is measured with an AC coupling mode, 5 cm wires, and in parallel with 0.1 μ F ceramic capacitor & 47 μ F electrolytic capacitor.

Mechanical

Case Cover / Chassis	Aluminium	
Dimensions (L x W x H)	215 x 115 x 50 mm (8.46 x 4.53 x 1.97 inch)	
Unit Weight	0.86 kg (1.90 lb)	
Indicator	Green LED (DC OK)	
Cooling System	Forced Cooling	
Terminal	PMF-5V320WCG□	M3.5 x 9 Pins (Rated 300 V/20 A)
	PMF-5V320WCA□	M3.5 x 9 Pins (Rated 300 V/15 A)
Wire	AWG 14-12*	
Noise (1 Meter from power supply)	Sound Pressure Level (SPL) <60 dBA	

*Only use wire that can withstand operating temperature of more than 125°C.

Environment

Surrounding Air Temperature	Operating	-10°C to +70°C (Cold start at -20°C)
	Storage	-25°C to +85°C
Power De-rating	> 50°C de-rate power by 2.5% / °C < 90 Vac de-rate power by 5% / 1 V	
Operating Humidity	5 to 95% RH (Non-Condensing)	
Operating Altitude	0 to 5,000 Meters (16,400 ft)	
Shock Test	Non-Operating	IEC 60068-2-27, Half Sine: 50 G for a duration of 11 ms, 3 shocks for each 3 directions
Vibration	Non-Operating	IEC 60068-2-6, Random: 5 Hz to 500 Hz (2.09 Grms); 20 min per axis for all X, Y, Z direction
Over Voltage Category	II	
Pollution Degree	2	

Protections

Overvoltage	5.75-7.30V, Latch Mode
Overload / Overcurrent	105-135%, Hiccup Mode, Non-Latching (Auto-Recovery)
Over Temperature	Hiccup Mode, Non-Latching (Auto-Recovery)
Short Circuit	Hiccup Mode, Non-Latching (Auto-Recovery)
Internal Fuse at L pin	F8AH
Protection Against Shock	Class I with PE* connection

*PE: Primary Earth

Reliability Data

MTBF	> 700,000 hrs. as per Telcordia SR-332 I/P: 100Vac, O/P: 100% load, Ta: 35°C
Expected Cap Life Time	10 years (115 Vac & 230 Vac, 50% load @ 40°C)

Safety Standards / Directives

Safety Entry Low Voltage		SELV (EN 60950-1)
Electrical Safety	TUV Bauart UL/cUL recognized	EN 60950-1, EN62368-1 UL 60950-1 and CSA C22.2 No. 60950-1 (File No. E131881) UL 62368-1 and CSA C22.2 No. 62368-1 (File No. E131881)
	CB scheme	IEC 60950-1, IEC 62368-1
CE		In conformance with EMC Directive 2014/30/EU and Low Voltage Directive 2014/35/EU
UKCA		In conformance with Electromagnetic Compatibility Regulations 2016 and Electrical Equipment (Safety) Regulations 2016
Galvanic Isolation	Input to Output	3.0 KVac
	Input to Ground	2.0 KVac
	Output to Ground	0.5 KVac

EMC

Emissions (CE & RE)		CISPR 32, EN/BS EN 55032, FCC Title 47: Class B
Immunity		EN/BS EN 55024
Electrostatic Discharge	IEC 61000-4-2	Criteria A ¹⁾ Level 3 Air Discharge: 8 kV Level 2 Contact Discharge: 4 kV
Radiated Field	IEC 61000-4-3	Level 2 Criteria A ¹⁾ 80 MHz-1 GHz, 10 V/M with 1 kHz tone / 80% modulation
Electrical Fast Transient / Burst	IEC 61000-4-4	Level 3 Criteria A ¹⁾ 1 kV
Surge	IEC 61000-4-5	Level 3 Criteria A ¹⁾ Common Mode ²⁾ : 2 kV Differential Mode ³⁾ : 1 kV
Conducted	IEC 61000-4-6	Level 2 Criteria A ¹⁾ 150 kHz-80 MHz, 3 Vrms
Power Frequency Magnetic Fields	IEC 61000-4-8	Criteria A ¹⁾ 1 A/Meter
Voltage Dips and Interruptions	IEC 61000-4-11	100% dip; 1 cycle (20 ms); Self Recoverable
Low Energy Pulse Test (Ring Wave)	IEC 61000-4-12	Level 3 Criteria A ¹⁾ Common Mode ²⁾ : 2 kV Differential Mode ³⁾ : 1 kV
Harmonic Current Emission		IEC/EN/BS EN 61000-3-2, Class A and Class D
Voltage Fluctuation and Flicker		IEC/EN/BS EN 61000-3-3

1) Criteria A: Normal performance within the specification limits
2) Asymmetrical: Common mode (Line to earth)
3) Symmetrical: Differential mode (Line to line)

Block Diagram

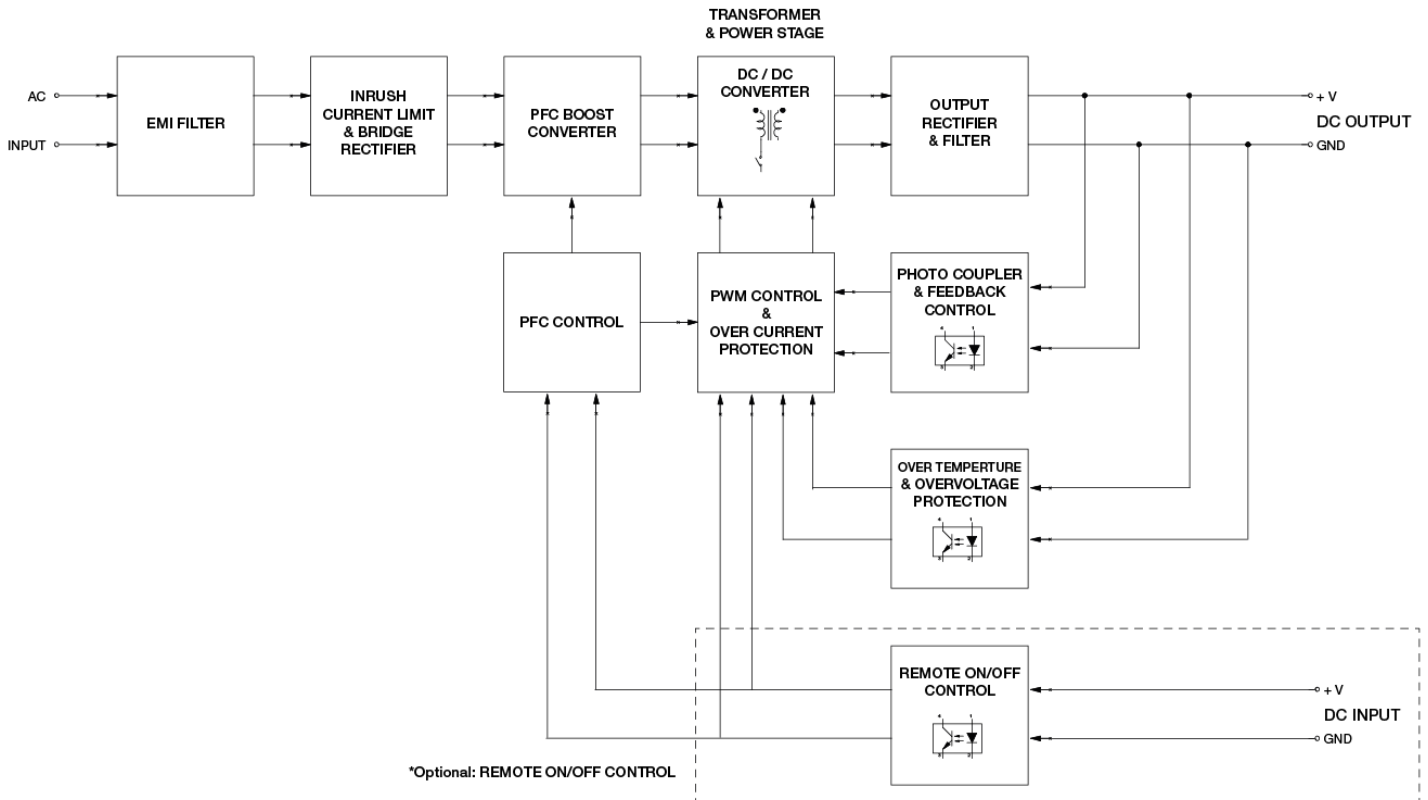

Device Descriptions

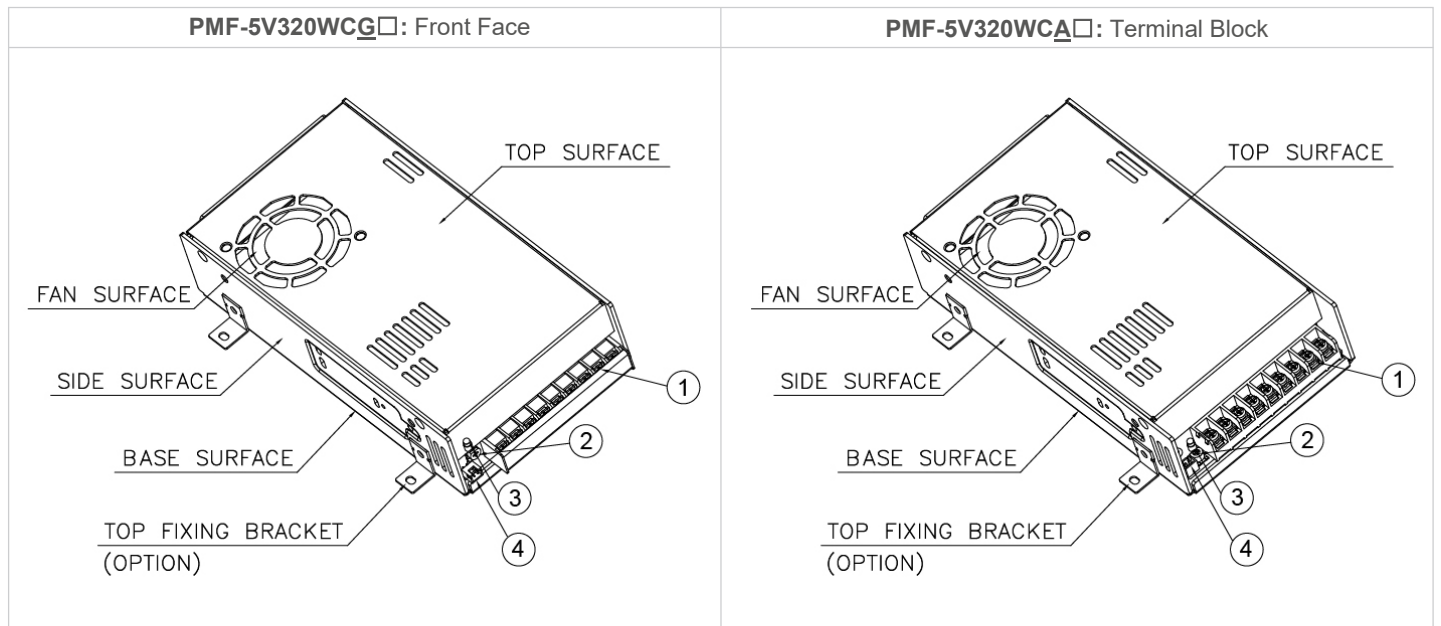

Item	Device Description
1	Input & Output terminal block connector
2	DC voltage adjustment potentiometer
3	DC OK control LED (Green)
4	Remote ON/OFF function connector (Option) (WST M2-I25002R)

Dimensions

PMF-5V320WCG□: Front Face

L x W x H: 215 x 115 x 50 mm (8.46 x 4.53 x 1.97 inch)

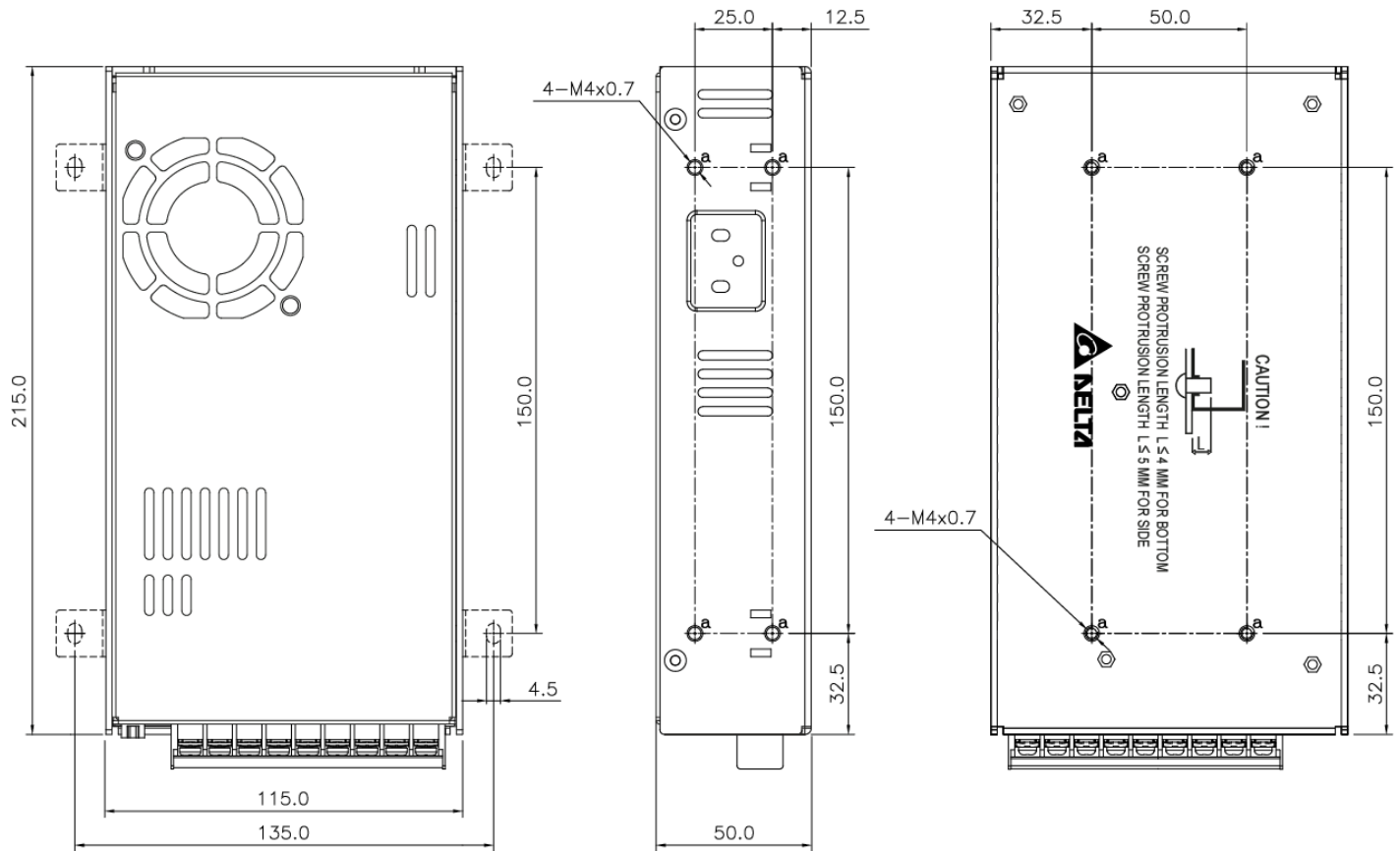

Note : Built-in cooling fan. Must prevent dust suction into power supply, or use natural convection power supply if any concerns.

PMF-5V320WCA□: Terminal Block
L x W x H: 215 x 115 x 50 mm (8.46 x 4.53 x 1.97 inch)

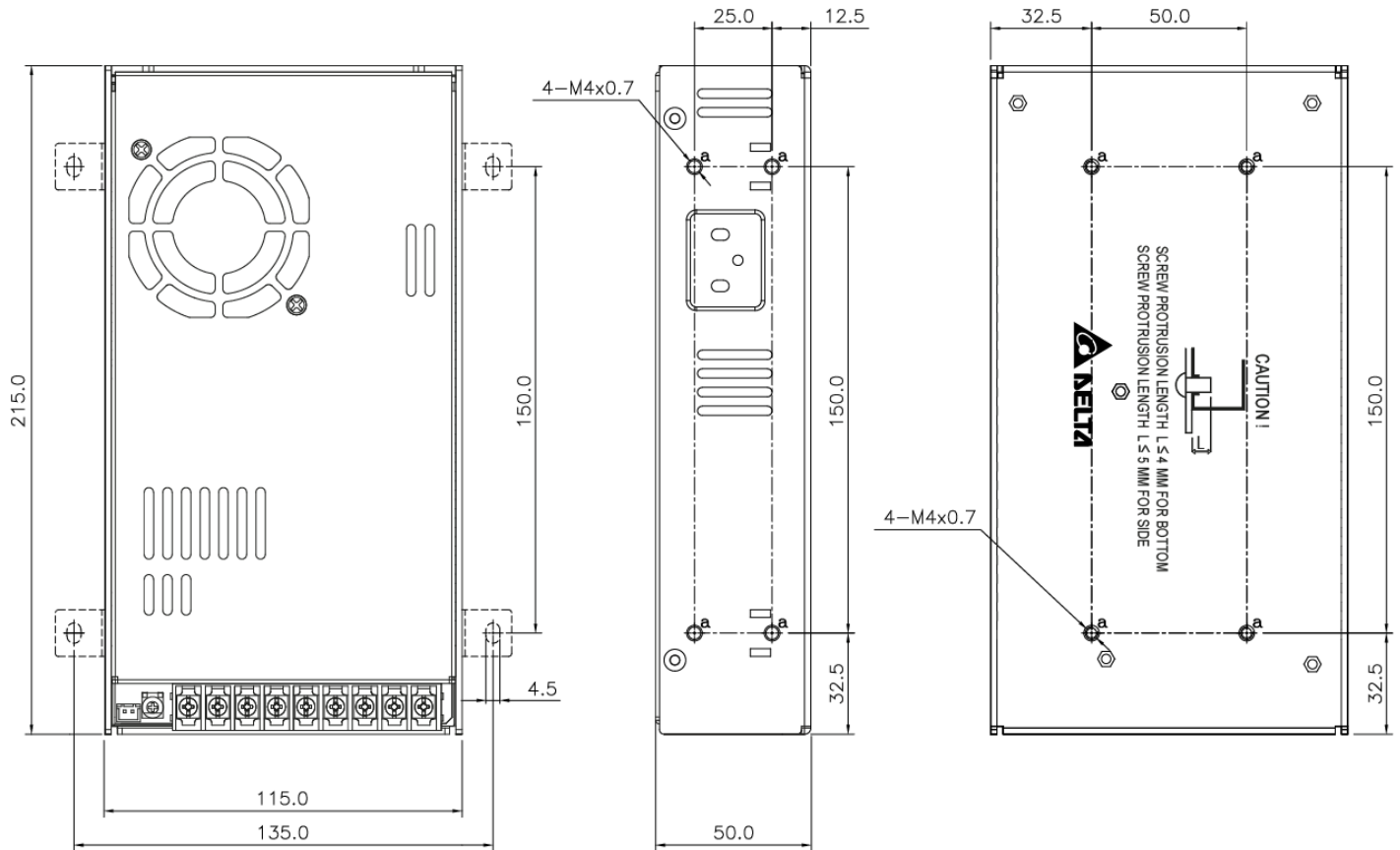

Note : Built-in cooling fan. Must prevent dust suction into power supply, or use natural convection power supply if any concerns.

Engineering Data

Output Load De-rating VS Surrounding Air Temperature

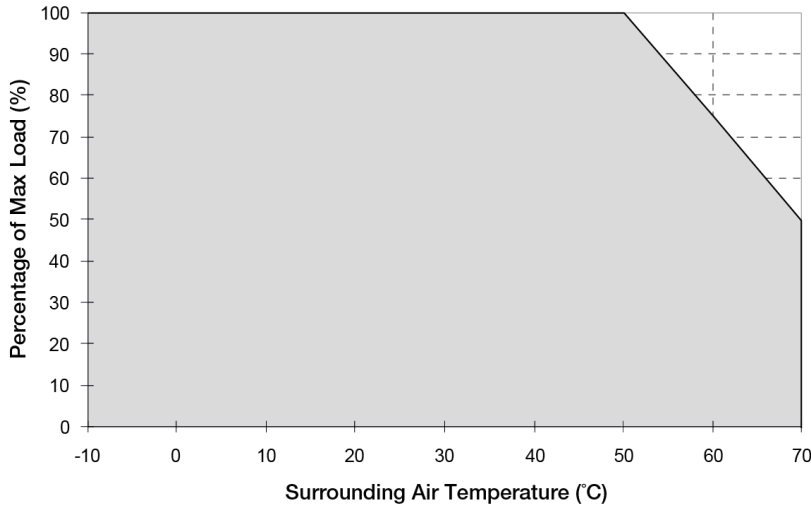

Note

1. Power supply components may degrade, or be damaged, when the power supply is continuously used outside the shaded region, refer to the graph shown in Fig. 1.
2. If the output capacity is not reduced when the surrounding air temperature exceeds its specification as defined on Page 3 under "Environment", the device will run into Over Temperature Protection. When activated, the output voltage will go into bouncing mode and will recover when the surrounding air temperature is lowered or the load is reduced as far as necessary to keep the device in working condition.
3. In order for the device to function in the manner intended, it is also necessary to keep a safety distance as recommended in the safety instructions while the device is in operation.
4. Depending on the surrounding air temperature and output load delivered by the power supply, the device can be very hot!
5. If the device has to be mounted in any other orientation, please contact info@deltapsu.com for more details.

Fig. 1 De-rating for Vertical and Horizontal Mounting Orientation
 > 50°C de-rate power by 2.5% / °C

Output Load De-rating VS Input Voltage

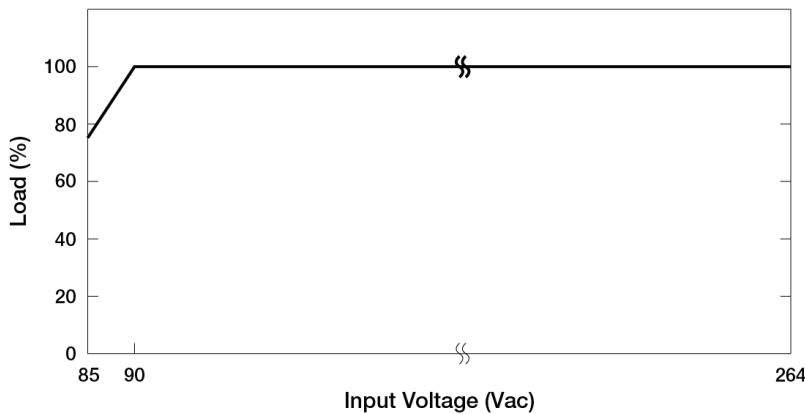

- No output power de-rating for the input voltage from 90 Vac to 264 Vac

■ L Frame / Enclosed

Assembly & Installation

- Ⓐ Side Mounting: Fig. 2 and Fig. 3 show the mounting hole locations for power supply assembly onto a metal mounting surface. The power supply shall be mounted on minimum of 4 mounting holes using M4 screw of maximum 5 mm (0.20 inch) length (Refer to Fig. 4). This is to maintain a safety distance between the screw and internal components.
- Ⓑ Base Mounting: Fig. 2 and Fig. 3 show the mounting hole locations for power supply assembly onto a metal mounting surface. The power supply shall be mounted on minimum of 4 mounting holes using M4 screw of maximum 4 mm (0.16 inch) length (Refer to Fig. 4). This is to maintain a safety distance between the screw and internal components.
- Ⓒ Connector
- Ⓓ This surface belongs to customer's end system or panel where the power supply is mounted.

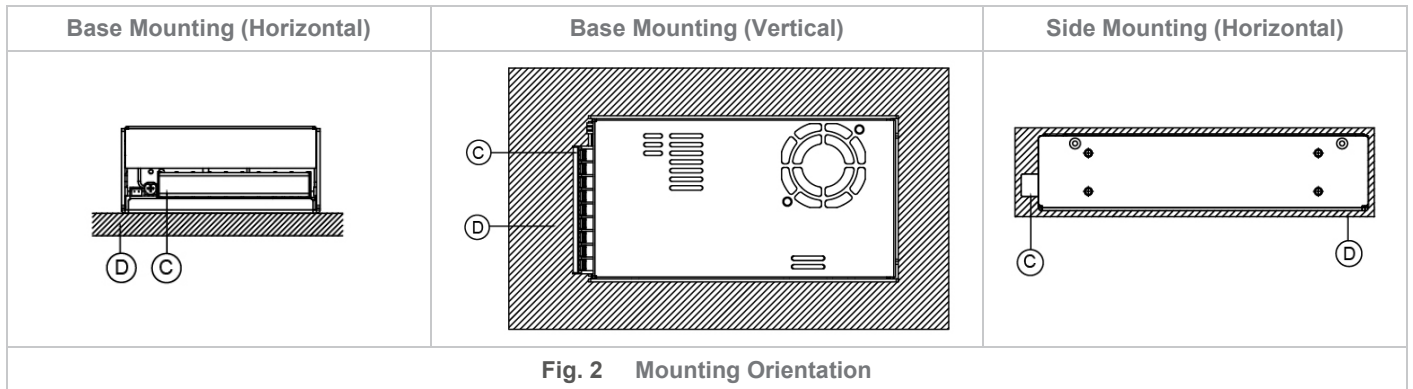

- Use flexible cable (stranded or solid) of AWG No. 14-12. The input/output connectors' allowable current is 23 A max per pin. User should calculate and select the suitable wire specification (type/quantity/diameter) according to actual output current. The torque at the connector shall not exceed 13 Kgf.cm. The insulation stripping length should not exceed 0.275" or 7 mm.
- Recommended mounting torque of the product and its mounting accessories is 9~12 Kgf.cm.

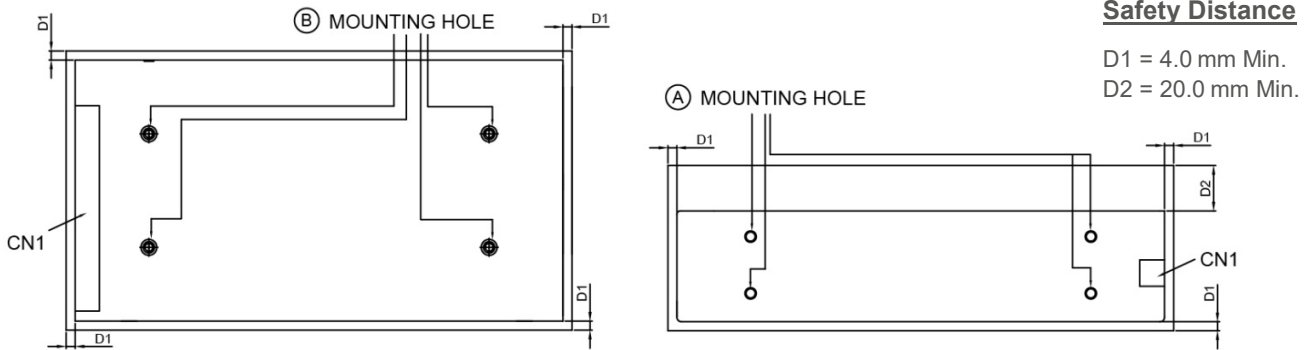

Fig. 3 Mounting Hole Locations and the Safety Distance

- Ensure the mounted device is kept at ≥ 4 mm safety distance at all sides from other components and equipment. In addition, to ensure sufficient convection cooling, always maintain a distance of ≥ 20 mm from ventilated surfaces while the device is in operation.
- For the Remote ON/OFF function (option), use flexible cable (stranded or solid) of AWG No. 28-22.

	Connector (Board Mounting)	Housing	Terminal
Remote ON/OFF Function (Option)	WST M2-I25002R	WST P2-I25002	WST I25002PS-2

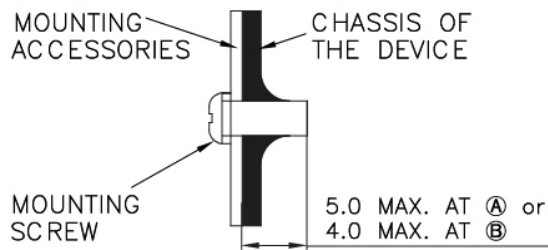

Fig. 4 Assembly Reference

- Only use M4 screw ≤ 5 mm (0.20 inch) through the base mounting holes at (A). This is to keep a safe distance between the screw and internal components.
- Only use M4 screws ≤ 4 mm (0.16 inch) through the base mounting holes at (B). This is to keep a safe distance between the screw and internal components.

Safety Instructions

- If user's mounting orientation is not according to the recommended mounting orientations, please consult Delta for further information.
- The device is not recommended to be placed on low thermal conductive surface. For example, plastics.
- The enclosure of the device can become very hot depending on the ambient temperature and load of the power supply. Do not touch the device while it is in operation or immediately after power is turned OFF. Risk of burning!
- Do not touch the terminals while power is being supplied. Risk of electric shock.
- Prevent any foreign metal, particles or conductors from entering the device through the openings during installation. It may cause electric shock, safety hazard, fire and/or product failure.
- Warning: When connecting the device, secure Earth connection before connecting L and N. When disconnecting the device, remove L and N connections before removing the Earth connection. The power supply must be mounted by metal screws onto a grounded metal surface. It is highly recommended that the Earth terminal on the connector be connected to the grounded metal surface.

Accessories

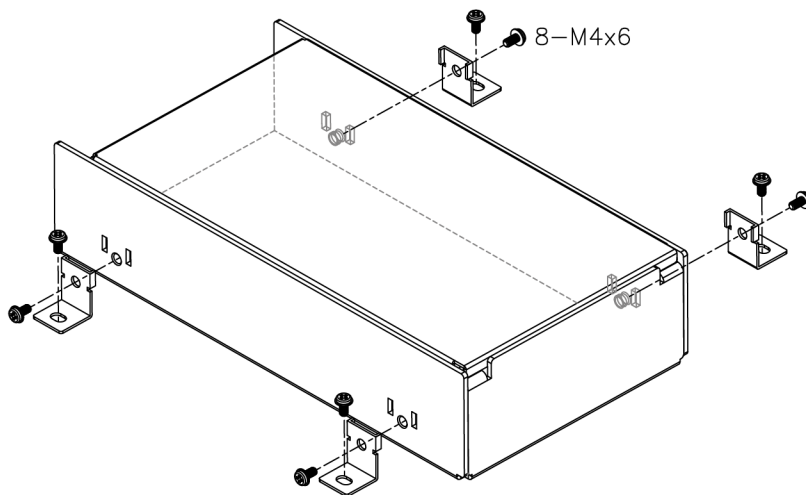

LM-01: Top Fixing Bracket

This bracket is used to fix the power supply onto a flat surface from the top.

Functional Manual

Remote ON/OFF Function

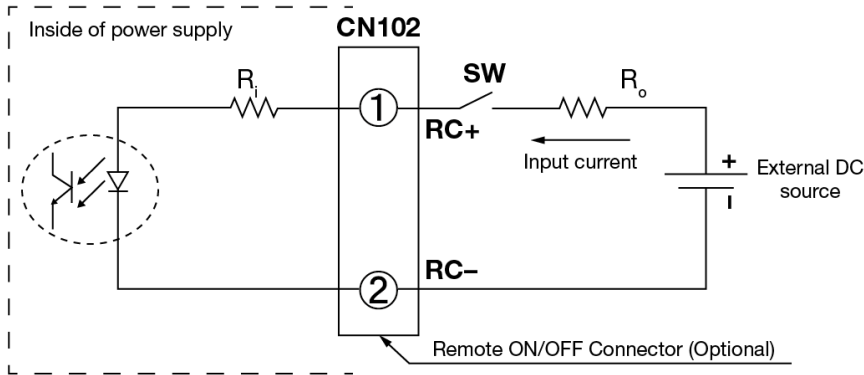

You can remotely control the power supply unit to turn ON/OFF by using an external DC source. Follow the DC power source voltage and current limiting defined in the table below.

Built-in Resistor R_i (ohm)	Voltage Between RC+ and RC- (V)		Input Current (mA)
	Output ON	Output OFF	
820	5-12.5	0-0.5	20 Max

Notes

1. Remote ON/OFF circuits are isolated from input, output and PE.
2. Please check if the polarity of the wire connector is the same as the external DC source. If not, the power would not turn on and the internal components may be damaged.
3. You do not need an external resistance R_o for current limit while the output voltage of external DC source is within the range of 5-12.5 V. If the output voltage exceeds 12.5 V, please use the following equation for the value of current limit resistance R_o .

$$R_o = \frac{V_{cc} - (3.5 + 0.006R_i)}{0.006}$$

Functions

Start-up Time

The time required for the output voltage to reach 90% of its final steady state set value, after the input voltage is applied.

Rise Time

The time required for the output voltage to change from 10% to 90% of its final steady state set value.

Hold-up Time

Time between the collapse of the AC input voltage, and the output falling to 95% of its steady state set value.

■ Graph illustrating the Start-up Time, Rise Time, and Hold-up Time

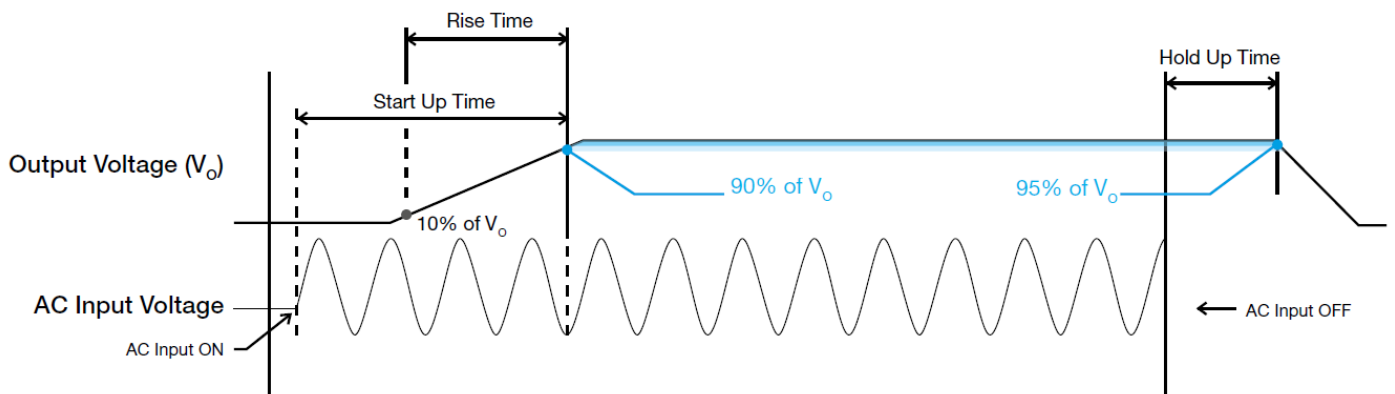

Inrush Current

Inrush current is the peak, instantaneous, input current measured and, occurs when the input voltage is first applied. For AC input voltages, the maximum peak value of inrush current will occur during the first half cycle of the applied AC voltage. This peak value decreases exponentially during subsequent cycles of AC voltage.

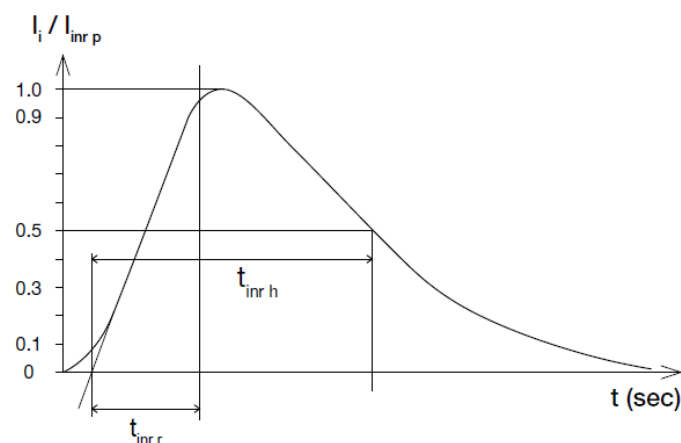

Dynamic Response

The power supply output voltage will remain within $\pm 5\%$ of its steady state value, when subjected to a dynamic load from 0 to 100% of its rated current.

■ 50% duty cycle / 5 Hz to 100 Hz

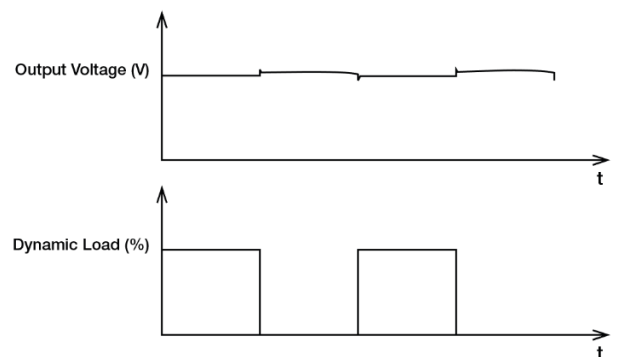

Overload & Overcurrent Protections (Auto-Recovery)

The power supply's Overload (OLP) and Overcurrent (OCP) Protections will be activated when output current exceeds 105-135% of I_O (Max load). In such occurrence, the V_O will start to droop and once the power supply has reached its maximum power limit, the protection is activated and the power supply will go into "Hiccup mode" (Auto-Recovery). The power supply will recover once the fault condition of the OLP and OCP is removed and I_O is back within the specifications.

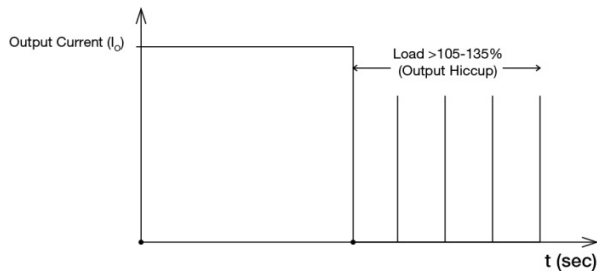

It is not recommended to prolong the duration of I_O when it is <105% but >100%, since it may cause damage to the PSU.

Short Circuit Protection (Auto-Recovery)

The power supply's output OLP/OCP function also provides protection against short circuits. When a short circuit is applied, the output current will operate in "Hiccup mode", as shown in the illustration in the OLP/OCP section on this page. The power supply will return to normal operation after the short circuit is removed.

Overvoltage Protection (Latch Mode)

The power supply's overvoltage circuit will be activated when its internal feedback circuit fails. The output voltage shall not exceed its specifications defined on Page 3 under "Protections". Power supply will latch off, and require removal/re-application of input AC voltage in order to restart.

The power supply should be latch.

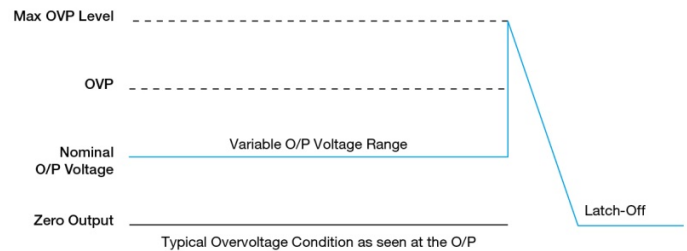

Over Temperature Protection (Auto-Recovery)

As described in load de-rating section, the power supply also has Over Temperature Protection (OTP). In the event of a higher operating temperature at 100% load, the power supply will run into OTP when the operating temperature is beyond what is recommended in the de-rating graph. When activated, the output voltage will go into bouncing mode until the temperature drops to its normal operating temperature as recommended in the de-rating graph.

Others

PFC – Norm EN 61000-3-2

Line Current Harmonic content

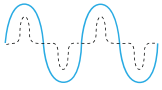

Typically, the input current waveform is not sinusoidal due to the periodical peak charging of the input capacitor. In industrial environment, complying with EN 61000-3-2 is only necessary under special conditions. Complying to this standard can have some technical drawbacks, such as lower efficiency as well as some commercial aspects such as higher purchasing costs. Frequently, the user does not profit from fulfilling this standard, therefore, it is important to know whether it is mandatory to meet this standard for a specific application.

(June 2022, Rev. 07)