



(MPM-65)



(MPM-65-xxST)



## ■ Features

- 3.43"x2.05" compact size
- PCB chassis or screw terminal mounting version
- Medical safety approved (2 x MOPP) according to ANSI/AAMI ES60601-1 and IEC/EN60601-1
- Suitable for BF application with appropriate system consideration
- No load power consumption < 0.1W
- Extremely low leakage current
- Wide operating temp. range -30 ~ +80°C
- EMI Class B without additional components
- Isolation Class II
- Protections: Short circuit / Overload / Over voltage
- No minimum load required
- Operating altitude up to 4000 meters( Note.7)
- 71W peak(10 sec.)
- 3 years warranty

## ■ Description

MPM-65 is a 65W high density and small size (87x52x29.5mm) AC/DC PCB-mount type medical grade power supply. It features the operation for 80~264VAC, a low no load power consumption less than 0.1W, a high efficiency up to 93%, Class II (no FG) double insulation, outstanding dissipation, 2~5G anti-vibration by model, high EMC performance, 4KVAC isolation, etc. The design observes IEC/EN60601-1 and ANSI/AAMI ES60601-1 version three with 2 x MOPP level and ultra-low leakage current (<100µA). It is very suitable for BF (patient contact) type medical device or relevant equipment.

## ■ Model Encoding

MPM - 65 - 5 ST

MPM : Series name  
65 : Rated wattage  
5 : Output voltage  
ST : Screw terminal style

{ Blank : PCB mounting style  
ST : Screw terminal style

**SPECIFICATION**

MODEL		MPM-65-5 <input type="checkbox"/>	MPM-65-12 <input type="checkbox"/>	MPM-65-15 <input type="checkbox"/>	MPM-65-24 <input type="checkbox"/>	MPM-65-48 <input type="checkbox"/>	
OUTPUT	DC VOLTAGE	5V	12V	15V	24V	48V	
	CURRENT	Peak(10 sec.)	11A	5.96A	4.77A	2.98A	1.49A
		Convection	10A	5.42A	4.33A	2.71A	1.36A
	RATED POWER	Peak(10 sec.) <sup>Note.2</sup>	55W	71.5W	71.6W	71.5W	71.5W
		Convection	50W	65W	65W	65W	65.3W
	RIPPLE & NOISE (max.) <sup>Note.3</sup>	80mVp-p	120mVp-p	120mVp-p	200mVp-p	240mVp-p	
	VOLTAGE TOLERANCE <sup>Note.4</sup>	±2.0%	±2.0%	±2.0%	±2.0%	±2.0%	
	LINE REGULATION	±0.5%	±0.5%	±0.5%	±0.5%	±0.5%	
	LOAD REGULATION	±1.0%	±1.0%	±0.5%	±0.5%	±0.5%	
SETUP, RISE TIME	1000ms, 30ms/230VAC    1000ms, 30ms/115VAC at full load						
HOLD UP TIME (Typ.)	50ms/230VAC    12ms/115VAC at full load						
INPUT	VOLTAGE RANGE <sup>Note.5</sup>	80 ~ 264VAC		113 ~ 370VDC			
	FREQUENCY RANGE	47 ~ 63Hz					
	EFFICIENCY (Typ.)	86.5%	92.5%	92.5%	93%	92%	
	AC CURRENT (Typ.)	1.5A/115VAC    1A/230VAC					
	INRUSH CURRENT (Typ.)	COLD START    30A/115VAC    65A/230VAC					
	LEAKAGE CURRENT (max.) <sup>Note.6</sup>	Touch current <100µA/264VAC					
PROTECTION	OVERLOAD	115% ~ 135% rated output power Protection type : Hiccup mode, recovers automatically after fault condition is removed					
	OVER VOLTAGE	5.3 ~ 7.2V	12.6 ~ 16.2V	15.8 ~ 20.3V	25.2 ~ 32.4V	50.4 ~ 64.8V	
	OVER TEMPERATURE	Protection type : Shut down o/p voltage, re-power on to recover					
ENVIRONMENT	WORKING TEMP.	-30 ~ +80°C (Refer to "Derating Curve")					
	WORKING HUMIDITY	20 ~ 90% RH non-condensing					
	STORAGE TEMP.	-40 ~ +85°C					
	TEMP. COEFFICIENT	±0.03%/°C (0 ~ 50°C)					
	SOLDERING TEMPERATURE	260°C ±5°C/10sec.max.					
	VIBRATION	Blank:10 ~ 500Hz, 2G 10min./1cycle, period for 60min. each along X, Y, Z axes					
		ST:10 ~ 500Hz, 5G 10min./1cycle, period for 60min. each along X, Y, Z axes					
	OPERATING ALTITUDE <sup>Note.7</sup>	4000 meters / OVC II					
SAFETY & EMC (Note 8)	SAFETY STANDARDS	IEC60601-1, EN60601-1, EAC TP TC 004, UL ANSI/AAMI ES60601-1(3.1 version), CAN/CSA-C22 3 <sup>rd</sup> Edition approved; Design refer to EN60335-1(by request)					
	ISOLATION LEVEL	Primary-Secondary: 2xMOPP					
	WITHSTAND VOLTAGE	I/P-O/P:4KVAC					
	ISOLATION RESISTANCE	I/P-O/P:100M Ohms / 500VDC / 25°C / 70% RH					
	EMC EMISSION	Parameter	Standard			Test Level / Note	
		Conducted	EN55011 (CISPR11)			Class B	
		Radiated	EN55011 (CISPR11)			Class B	
		Harmonic Current	EN61000-3-2			Class A	
	Voltage Flicker	EN61000-3-3			-----		
	EMC IMMUNITY	EN60601-1-2					
Parameter		Standard			Test Level / Note		
ESD		EN61000-4-2			Level 4, 15KV air ; Level 4, 8KV contact		
RF field susceptibility		EN61000-4-3			Level 3, 10V/m( 80MHz~2.7GHz ) Table 9, 9~28V/m( 385MHz~5.78GHz )		
EFT bursts		EN61000-4-4			Level 3, 2KV		
Surge susceptibility		EN61000-4-5			Level 3, 1KV/Line-Line		
Conducted susceptibility		EN61000-4-6			Level 3, 10V		
Magnetic field immunity		EN61000-4-8			Level 4, 30A/m		
Voltage dip, interruption	EN61000-4-11			>95% dip 0.5 periods, 30% dip 25 periods, >95% interruptions 250 periods			
OTHERS	MTBF	563.44Khrs min.    MIL-HDBK-217F (25°C);		1530.14Khrs min.    Telcordia TR/SR-332 (Bellcore) (25°C)			
	DIMENSION	PCB mounting style : 87*52*29.5mm (L*W*H)			Screw terminal style : 109*52*33.5mm (L*W*H)		
	PACKING	PCB mounting style : 0.191Kg;60pcs/12.5Kg/0.97CUFT			Screw terminal style :0.216Kg;50pcs/11.8Kg/0.55CUFT		
NOTE	<ol style="list-style-type: none"> <li>All parameters NOT specially mentioned are measured at 230VAC input, rated load and 25°C of ambient temperature.</li> <li>33% Duty cycle maximum within every 30 seconds. Average output power should not exceed the rated power.</li> <li>Ripple &amp; noise are measured at 20MHz of bandwidth by using a 12" twisted pair-wire terminated with a 0.1 µf &amp; 47 µf parallel capacitor.</li> <li>Tolerance : includes set up tolerance, line regulation and load regulation.</li> <li>Derating may be needed under low input voltages. Please check the derating curve for more details.</li> <li>Touch current was measured from primary input to DC output.</li> <li>The ambient temperature derating of 3.5°C/1000m with fanless models and of 5°C/1000m with fan models for operating altitude higher than 2000m(6500ft).</li> <li>The power supply is considered a component which will be installed into a final equipment. The final equipment must be re-confirmed that it still meets EMC directives. For guidance on how to perform these EMC tests, please refer to "EMI testing of component power supplies."</li> </ol>						

**Block Diagram**

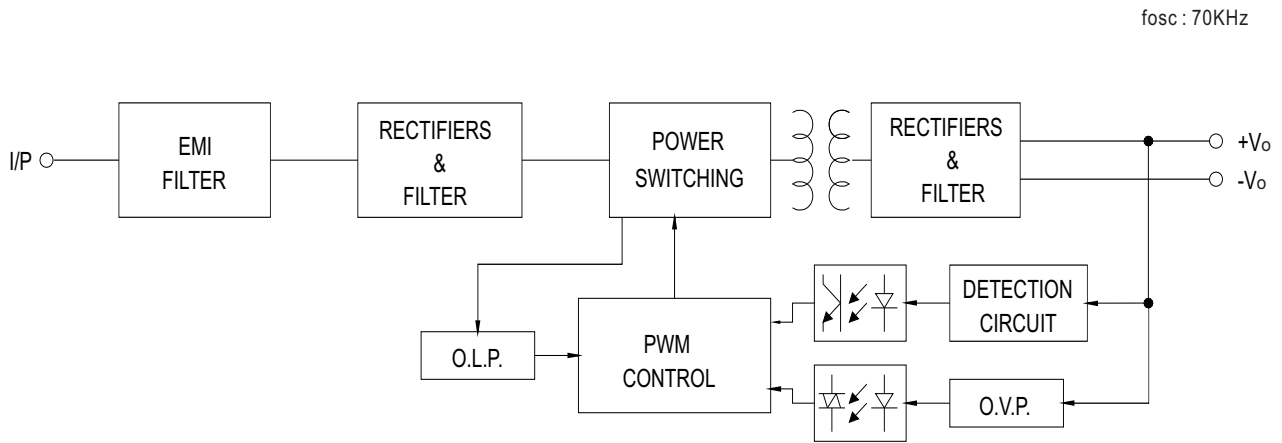

**Derating Curve**

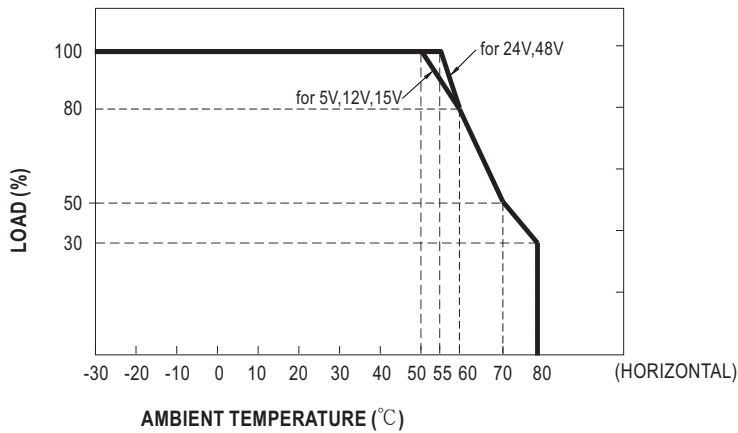

**Output Derating VS Input Voltage**

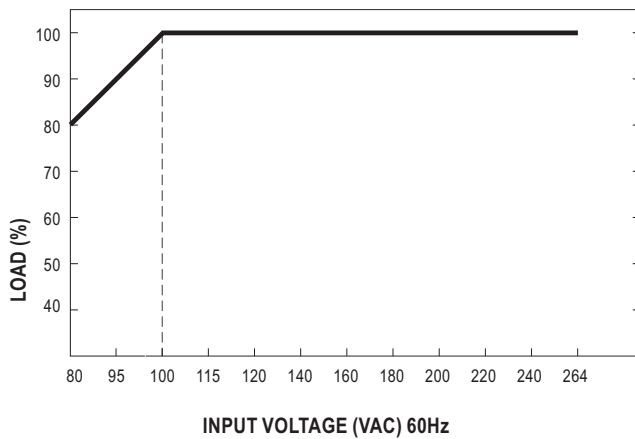

■ **Mechanical Specification**

Case No. IRM60 Unit:mm

- PCB mounting style (MPM-65)

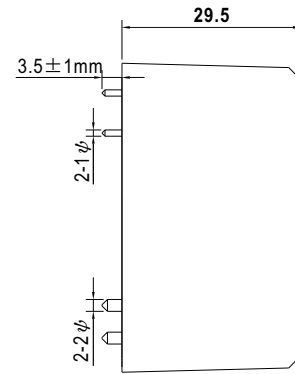
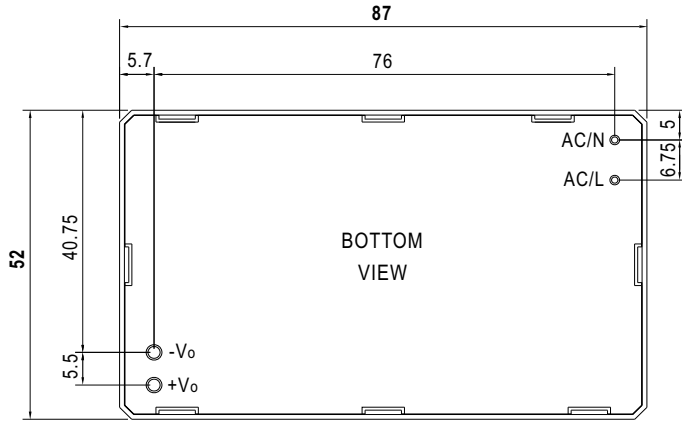

AC/L, AC/N P/N diameter: 1 φ  
 +Vo, -Vo P/N diameter: 2 φ

- Screw terminal style (MPM-65-xxST)

