



GREEN XP POWER

- Ultra Compact Size
- Single Outputs from 3.3 to 48 V
- Encapsulated
- PCB & Chassis Mount Versions
- <0.3 W No Load Input Power
- Peak Load Capability
- 3 Year Warranty

Specification

Input

Input Voltage	• 85-264 VAC (120-370 VDC) derate load from 100% at 90 VAC to 90% at 85 VAC
Input Frequency	• 47-63 Hz
Input Current	• ECE20: 0.3 A rms at 230 VAC ECE40: 0.5 A rms at 230 VAC
Inrush Current	• 20 A at 115 VAC, 40 A at 230 VAC, cold start at 25 °C
Power Factor	• EN61000-3-2 Class A
Earth Leakage Current	• Class II construction no earth
No Load Input Power	• <0.3 W
Input Protection	• ECE20: Internal T1 A/250 VAC fuse ECE40: Internal T2 A/250 VAC fuse

Output

Output Voltage	• See tables
Initial Set Accuracy	• ±1%
Minimum Load	• No minimum load required
Start Up Delay	• 2 s max
Start Up Rise Time	• 16 ms max
Hold Up Time	• 8 ms minimum at full load & 115 VAC
Line Regulation	• ±0.5% max
Load Regulation	• ±1% max, ±2% max for ECE40US03/05-S
Transient Response	• 4% max deviation, recovery to within 1% in 500 µs for a 25% load change
Ripple & Noise	• 3.3-5 V versions: 60 mV pk-pk, 3.3-5 V 'ECE40-S' versions: 75 mV pk-pk (see note 5), all other models 1% pk-pk max 20 MHz bandwidth
Overvoltage Protection	• 115-140% Vnom, 195-216% Vnom ECE20US03 / ECE40US03
Overload Protection	• 110-180%
Short Circuit Protection	• Trip and restart (hiccup mode)
Temperature Coefficient	• 0.05%/°C

General

Efficiency	• See tables
Isolation	• 3000 VAC Input to Output
Switching Frequency	• 100 kHz typical
Power Density	• ECE20: 9.97 W/In ³ ECE40: 7.82 W/In ³
MTBF	• >450 kHrs to MIL-HDBK-217F at 25 °C, GB

Environmental

Operating Temperature	• -25 °C to +70 °C, derate linearly from 100% at +50 °C to 50% at +70 °C
Cooling	• Convection-cooled
Operating Humidity	• 95% RH, non-condensing
Storage Temperature	• -40 °C to +85 °C
Operating Altitude	• 3000 m
Vibration	• 2 g, 10 Hz to 500 Hz, 10 mins/cycle, 60 mins each of 3 axes.

EMC & Safety

Emissions	• EN55032, level B conducted & radiated
Harmonic Currents	• EN61000-3-2, EN61000-3-3
ESD Immunity	• EN61000-4-2, level 3 Perf Criteria A
Radiated Immunity	• EN61000-4-3, 10 V/m 80% mod Perf Criteria A
EFT/Burst	• EN61000-4-4, level 3 Perf Criteria A
Surge	• EN61000-4-5, installation Class 3, Perf Criteria A
Conducted Immunity	• EN61000-4-6, 10 Vrms Perf Criteria A
Magnetic Fields	• EN61000-4-8, 10 A/m Perf Criteria A
Dips & Interruptions	• EN61000-4-11, 30% for 10 ms, 60% for 100 ms, 100% for 5000 ms Perf Criteria A, B, B
Safety Approvals	• IEC60950-1:2005 Ed 2 / IEC62368-1:2014 UL 62368-1 & CAN/CSA C22.2 No. 62368-1-14, EN62368-1:2014/A11:2017

Models and Ratings

ECE20/40 XP

Output Power	Output Voltage	Output Current		Efficiency ⁽⁴⁾	Model Number
		Nominal	Peak ⁽¹⁾		
15.0 W	3.3 VDC	4.55 A	5.85 A	73%	ECE20US03
20.0 W	5.0 VDC	4.00 A	5.20 A	77%	ECE20US05
20.0 W	9.0 VDC	2.22 A	2.89 A	83%	ECE20US09
20.0 W	12.0 VDC	1.67 A	2.17 A	82%	ECE20US12
20.0 W	15.0 VDC	1.33 A	1.73 A	83%	ECE20US15
20.0 W	24.0 VDC	0.83 A	1.08 A	82%	ECE20US24
20.0 W	48.0 VDC	0.42 A	0.55 A	86%	ECE20US48
33.0 W	3.3 VDC	10.00 A	13.00 A	73%	ECE40US03 ⁽²⁾⁽³⁾
40.0 W	5.0 VDC	8.00 A	10.40 A	77%	ECE40US05 ⁽²⁾⁽³⁾
40.0 W	9.0 VDC	4.44 A	5.77 A	80%	ECE40US09 ⁽²⁾⁽³⁾
40.0 W	12.0 VDC	3.33 A	4.33 A	84%	ECE40US12 ⁽²⁾⁽³⁾
40.0 W	15.0 VDC	2.67 A	3.47 A	84%	ECE40US15 ⁽²⁾⁽³⁾
40.0 W	24.0 VDC	1.67 A	2.17 A	85%	ECE40US24 ⁽²⁾⁽³⁾
40.0 W	48.0 VDC	0.83 A	1.08 A	86%	ECE40US48 ⁽²⁾⁽³⁾

Notes

- Peak load lasting <30 s with a maximum duty cycle of 10%, average output power not to exceed nominal power.
- Add suffix -S to model number to denote chassis mount with screw terminal type, e.g. ECE40US12-S. Only available with ECE40 models.
- A screw terminal versions (-S) is available with DIN Clip attached. Add suffix 'D', e.g. ECE40US24-SD. DIN Rail mounting clip is available as a separate item, order code ECL25/30 DIN CLIP.
- Average of efficiencies measured at 25%, 50%, 75% & 100% load with 230 VAC input.
- 3.3 & 5 V ECE40-S versions meet 75 mV pk-pk with 20 MHz bandwidth and 0.1 μ F capacitor across output terminals.

Mechanical Details

ECE20

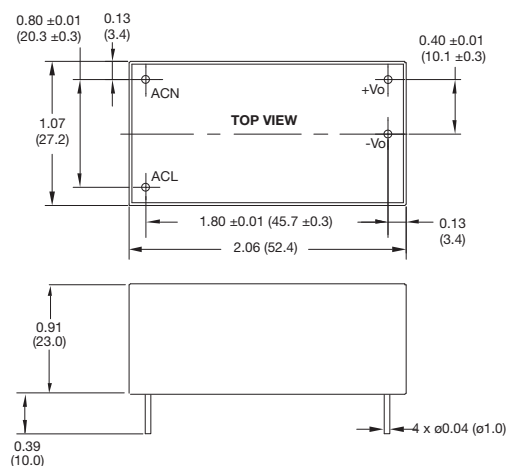

ECE40

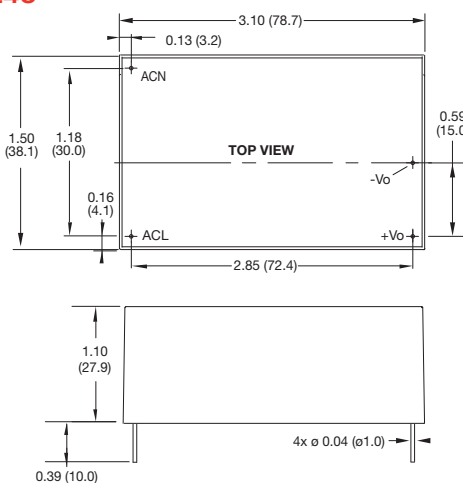

ECE40 Screw Terminal (-S)

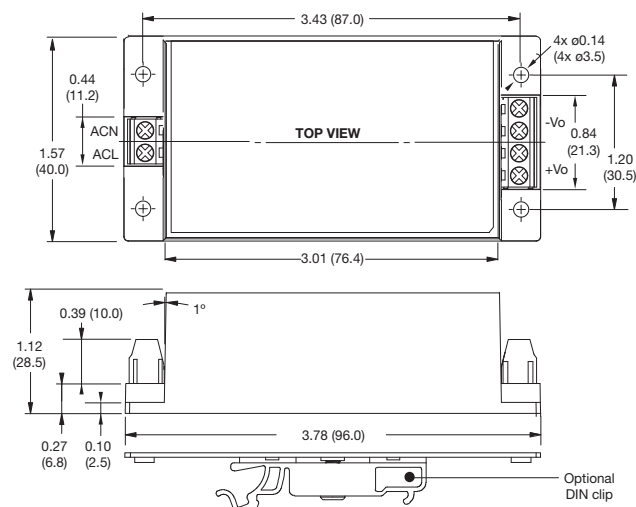

Notes

- All dimensions in inches (mm).
- Weight: ECE20: 0.13 lbs (60 g)
ECE40: 0.33 lbs (150 g)
ECE40 Optional Screw Terminal: 0.37 lbs (170 g)
- Tolerances: x.xx \pm 0.02 (x.x \pm 0.5), x.xxx \pm 0.01 (x.xx \pm 0.25)