

3W CONVECTION COOLED

The E Series is a broad line of small, component level high voltage converters in a PCB mount package that provides up to 3 Watts continuous output power for models up to 7kV (2 Watts for models >7kV). These HV converters feature low ripple and noise, and low EMI/RFI by utilizing a quasi-sinewave oscillator, excellent filtering techniques and a fully enclosed pot-core transformer. The output voltage is directly proportional to the input voltage and is linear from approximately 0.7 volts to maximum input.

The galvanically isolated output allows for user selectable output polarity. Dual output models with a center-tap pin provide both positive and negative outputs from one module. Some models are provided with an external aluminum box for increased EMI/RFI shielding and rugged mounting. Proven design techniques, classic topology and custom encapsulation formula come together to provide engineers with a clean, reliable, low cost, and easy to integrate high voltage solution.

Features

- Output Voltages from 100V to 12kV
- Output Voltage Proportional to Input
- Low Turn-on Voltage 0.7VDC
- Input to Output Isolation
- Dual Output
- No Minimum Load
- 3 Year Warranty

Block Diagram

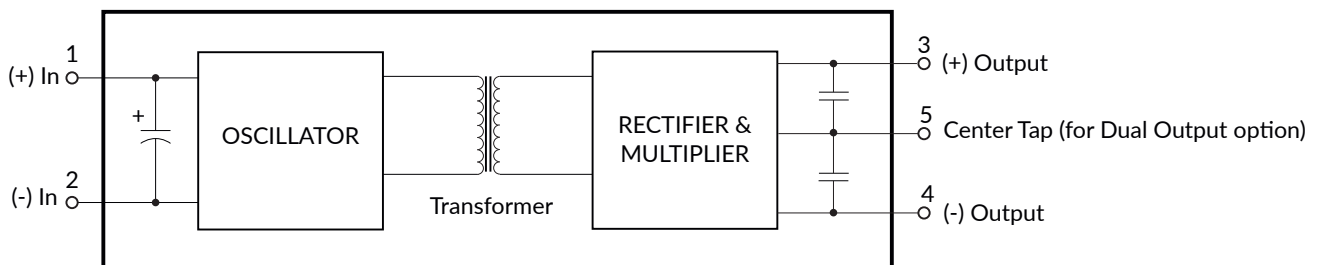

DC-HVDC CONVERTER



Typical Applications



- Mass Spectrometry
- Electrostatic Chucks
- Electrophoresis
- Capacitor Charging
- Particle Counter
- Ignition/Spark
- Sustaining Ion Pumps

Dimensions

2.50 x 1.5 x 0.85" (63.5 x 38.1 x 21.6mm)

Input

Characteristic	Minimum	Typical	Maximum	Units	Notes & Conditions
Input Voltage Range	0.7		12, 15	VDC	See Models & Ratings table
Input Current, Full Load			175	mA	
Input Current, No Load			400	mA	

Output

Characteristic	Minimum	Typical	Maximum	Units	Notes & Conditions
Output Voltage			12000	VDC	See Models & Ratings table
Output Current			30	mA	See Models & Ratings table
Output Voltage Tolerance		±5		%	At Max Vout, Full Load
Minimum Load	No minimum load required				
Regulation	Unregulated, Output is proportional to Input. See Application Notes				
Ripple and Noise	0.05		1.5	%	See Models & Ratings table
Response Time		10		msec	0 to Max Vout, Full Load

Environmental

Characteristic	Minimum	Typical	Maximum	Units	Notes & Conditions
Operating Temperature (case)	-10		+60	°C	Models E01 to E60
Operating Temperature (case)	-10		+50	°C	Models E70 to E121
Storage Temperature	-25		+90	°C	
Cooling	Natural convection				
Humidity			95	%RH	Non-condensing

General

Characteristic	Minimum	Typical	Maximum	Units	Notes & Conditions
Isolation: Input to Output			3500	V	<±3500 Bias for Models E01 to E60
Isolation: Input to Output			500	V	<±500 Bias for Models E70 to E121
Switching Frequency	30		100	kHz	Stable frequency over entire output voltage range
Construction	Case material is Diallyl Phthalate (DAP). UL 94 V-0 rated solid vacuum encapsulation.				
Mean Time Between Failure	810			khrs	Per Bellcore TR 332

Notes:

- Maximum rated output current is available at maximum rated output voltage and derates linearly as input voltage is decreased.
- Output voltage is load dependent. Under light or no-load conditions, reduce the input voltage so maximum rated output voltage is not exceeded.
- Specifications after 30 minute warm-up, full load, at 25°C unless otherwise indicated.
- Proper thermal management techniques are required to maintain safe case temperature at maximum power output.
- Ripple specification for center-tapped units applies to the voltage between the positive and negative output terminals.

External EMI/RFI Shield

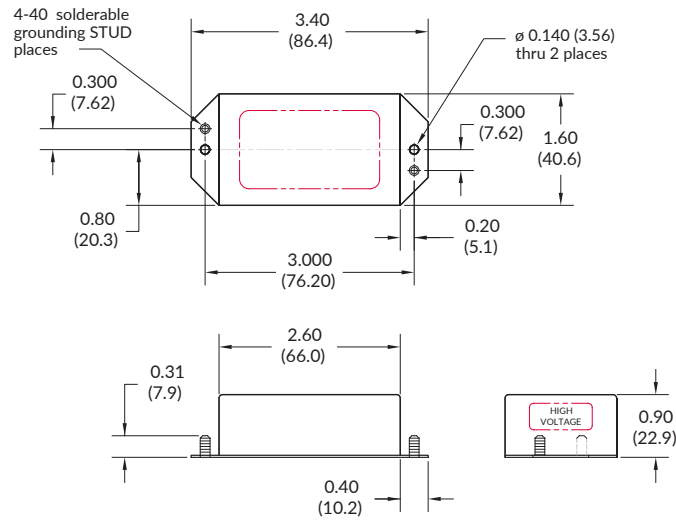

An AB suffix is used to indicate an added external EMI/RFI Shield as shown above. These five-sided aluminum enclosures feature a durable, non-conductive black anodized finish. On models with outputs of 3kV or higher, special care must be taken to ensure adequate spacing and insulation between the metal can and the high voltage output. Single sided layout, encapsulation, or conformal coating may be required. Case grounding studs must be connected to ground. Case ground is not connected to (-) Input.

Models and Ratings

Model Number	Output Voltage	Output Current ⁽¹⁾	Input Voltage	Ripple
E01	0 to 100V	30mA	0 to 12V	<0.2%
E02	0 to 200V	15mA	0 to 12V	<0.25%
E03	0 to 300V	10mA	0 to 12V	<1%
E03AB	0 to 300V	10mA	0 to 12V	<1%
E03CTR	0 to ±150V	10mA	0 to 12V	<1%
E05	0 to 500V	6mA	0 to 12V	<0.1%
E05CT	0 to ±250V	6mA	0 to 12V	<0.1%
E06	0 to 600V	5mA	0 to 12V	<0.1%
E06CT	0 to ±300V	5mA	0 to 12V	<0.1%
E06CTAB	0 to ±300V	5mA	0 to 12V	<0.1%
E08	0 to 800V	3.7mA	0 to 12V	<0.1%
E08CTR	0 to ±400V	3.7mA	0 to 12V	<0.1%
E10	0 to 1000V	3mA	0 to 12V	<0.05%
E10CT	0 to ±500V	3mA	0 to 12V	<0.05%
E10CTAB	0 to ±500V	3mA	0 to 12V	<0.05%
E12R	0 to 1200V	2.5mA	0 to 12V	<0.05%
E12CT	0 to ±600V	2.5mA	0 to 12V	<0.05%
E15	0 to 1500V	2mA	0 to 12V	<0.05%
E15CT	0 to ±750V	2mA	0 to 12V	<0.05%
E20	0 to 2000V	1.5mA	0 to 12V	<0.25%
E30	0 to 3000V	1mA	0 to 15V	<0.25%
E30CT	0 to ±1500V	1mA	0 to 15V	<0.25%
E40	0 to 4000V	0.75mA	0 to 15V	<0.5%
E50	0 to 5000V	0.6mA	0 to 15V	<0.5%
E50CT	0 to ±2500V	0.6mA	0 to 15V	<0.5%
E60	0 to 6000V	0.5mA	0 to 15V	<0.5%
E60RAB	0 to 6000V	0.5mA	0 to 15V	<0.5%
E60CT	0 to ±3000V	0.5mA	0 to 15V	<0.5%
E70	0 to 7000V	0.43mA	0 to 15V	<1%
E70RAB	0 to 7000V	0.43mA	0 to 15V	<1%
E70CT	0 to ±3500V	0.43mA	0 to 15V	<1%
E80	0 to 8000V	0.25mA	0 to 15V	<1.25%
E80CT	0 to ±4000V	0.25mA	0 to 15V	<1.25%
E101	0 to 10kV	0.2mA	0 to 15V	<1.5%
E121	0 to 12kV	0.16mA	0 to 15V	<1.5%
E121RAB	0 to 12kV	0.16mA	0 to 15V	<1.5%

Notes:

1. All orderable part numbers are listed above.
2. CT indicates dual output, center tap. Negative side will be ~10% larger than positive side w.r.t. the center tap pin.
3. AB suffix indicates external shield, see Mechanicals.
4. R suffix is used as a RoHS indicator for legacy models.

Mechanical Details

E01-E60

Top View

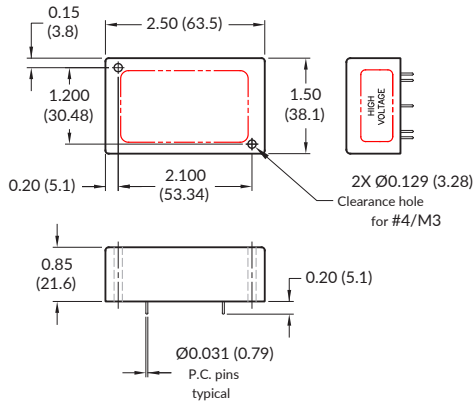

PCB Layout

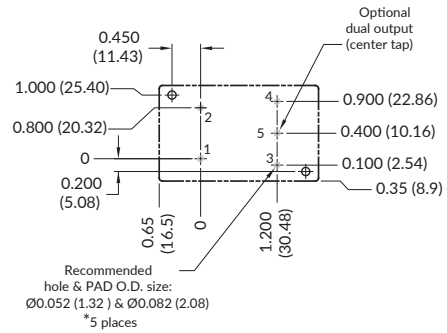

E70-E121

Top View

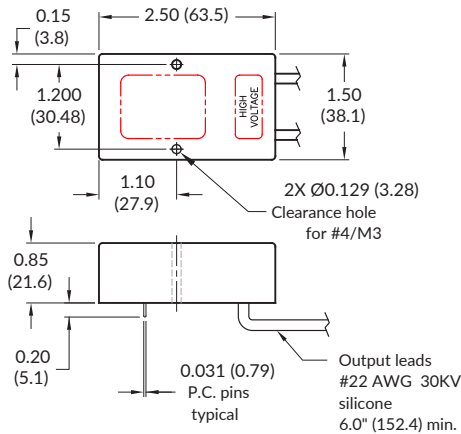

PCB Layout

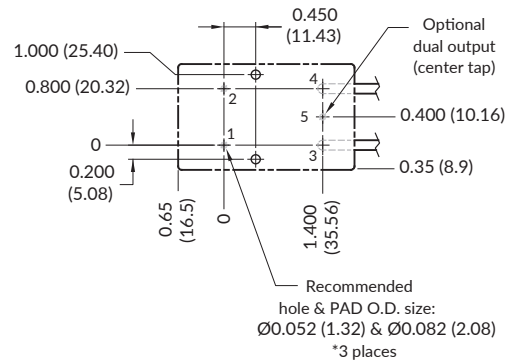

Pin	Function
1	(+) Input
2	(-) Input
3	(+) Output
4	(-) Output
5	Dual Output/Center Tap (Optional)

Notes:

1. All dimensions are in inches (mm)
2. Weight 3oz (85g)
3. Tolerance: X.XX±0.02 (0.51)
4. Pin Tolerance: ±0.005 (0.127)

Application Notes

Positive Output

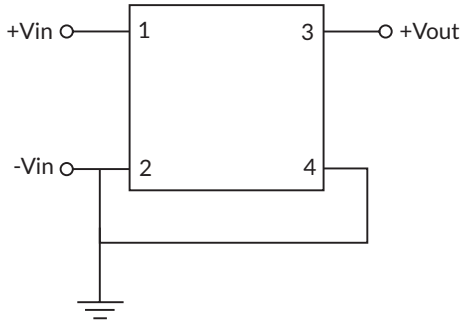

Negative Output

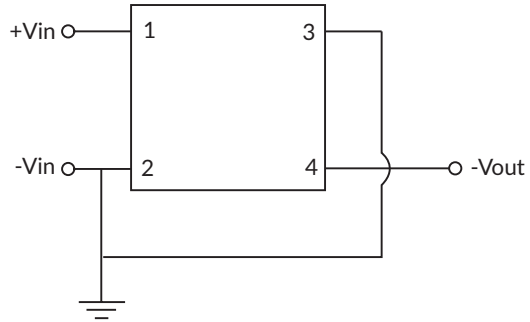

Dual Output

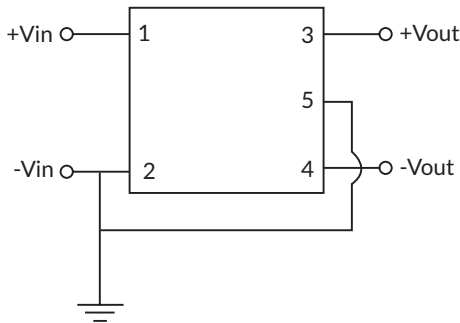

Typical Output vs. Input Voltage

