

sync

Highlights & Features

- Ultra-compact size and galvanic isolation up to 3.0kVac
- Universal AC input voltage range and full power from -10°C to +55°C operation
- Up to 82.0% efficiency
- Low earth leakage current < 0.75mA @ 264Vac
- Built-in DC OK relay contact option available
- Extreme low temperature cold start at -40°C
- NEC Class 2 / Limited Power Source (LPS) certified (DRS-5V50W1N□)
- Certified according to IEC/EN/UL 62368-1

Safety Standards



CB Certified for worldwide use



*This picture is for reference to DRS-5V50W series only.

Model Number:	DRS-5V50W1□□
Unit Weight:	0.16 kg (0.35 lb)
Dimensions (L x W x D):	75 x 30 x 89.5 mm (2.95 x 1.18 x 3.52 inch)

General Description

The ultra-compact and competitively priced Delta Sync DIN Rail DRS-5V50W1□□ power supply is designed for industrial applications requiring highly reliable power supply that must fit in a small space. The Sync series operates with universal AC input range and offers full power up to 55°C. The output is adjustable from 5-5.5 volts, and can support up to 3000 microfarads of load capacitance. A green LED indicates output is present. All models in the series are certified according to IEC/UL 60950-1, IEC/EN/UL 62368-1 Information Technology Equipment (ITE) and UL 508 Industrial Control Equipment (ICE). The series is also fully compliant with RoHS Directive (EU) 2015/863 for environmental protection. NEC Class 2 and Limited Power Source (LPS) approvals are available for DRS-5V50W1N□.

Model Information

Sync DIN Rail Power Supply

Model Number	Input Voltage Range	Rated Output Voltage	Rated Output Current
DRS-5V50W1A□	85-264 Vac (120-375 Vdc)	5 Vdc	6.0 A
DRS-5V50W1N□			5.0 A

Model Numbering

DR	S –	5V	50W	1	□	□
DIN Rail	Product Series S – Sync Series	Output Voltage	50W series	Single Phase	A – Non NEC Class 2 N – NEC Class 2	Z – Without DC OK Relay Contact R – With DC OK Relay Contact

Specifications

Model Number		DRS-5V50W1A□	DRS-5V50W1N□
Input Ratings / Characteristics			
Nominal Input Voltage		100-240 Vac	
Input Voltage Range		85-264 Vac	
Nominal Input Frequency		50-60 Hz	
Input Frequency Range		47-63 Hz	
DC Input Voltage Range*		120-375 Vdc	
Input Current		< 0.6 A @ 115 Vac, < 0.4 A @ 230 Vac	
Efficiency at 100% Load		> 82% @ 115 Vac & 230 Vac	
Max Power Dissipation	0% load	< 0.7 W @ 115 Vac & 230 Vac	
	100% load	< 7.0 W @ 115 Vac & 230 Vac	
Max Inrush Current (Cold Start)		< 30 A @ 115 Vac, < 60 A @ 230 Vac	
Leakage Current		< 0.75 mA @ 264 Vac	

*Fulfills test conditions for DC input. Safety approval for DC input can be obtained upon request.

Output Ratings / Characteristics**

Nominal Output Voltage		5 Vdc	
Factory Set Point Tolerance		5 Vdc ± 2%	
Output Voltage Adjustment Range		5-5.5 Vdc	
Output Current		6.0 A (30 W max.)	5.0 A (25 W max.)
Output Power		30 W	25 W
Line Regulation		< 0.5% (@ 85-264 Vac, 100% load)	
Load Regulation		< 1.0% (@ 85-264 Vac, 0-100% load)	
PARD*** (20MHz)		< 50mVpp @ > 0°C to 70°C < 100 mVpp @ 0°C to -20°C	
Rise Time		< 30 ms @ nominal input (100% load)	
Start-up Time		< 2,000 ms @ 115 Vac (100% load)	
		< 1,000 ms @ 230 Vac (100% load)	
Hold-up Time		> 20 ms @ 115 Vac, > 100 ms @ 230 Vac (100% load)	
Dynamic Response (Overshoot & Undershoot O/P Voltage)		± 5% @ 85-264 Vac input, 10-100% load (Slew Rate: 0.1 A/μs, 50% duty cycle @ 5 Hz to 1 KHz)	
Start-up with Capacitive Loads		3,000 μF Max	
Functional	DC OK Relay Contact (for DRS-5V50W1AR, DRS-5V50W1NR)	30 V / 1 A, resistive load The relay contact are normally "ON" (closed) when the output (Vout) is greater than 75% of its rated value and "OFF" (opened) when the output (Vout) is less than 75% typ.	

**For power de-rating from < -10°C to -20°C, and 55°C to 70°C, see power de-rating on page 3.

***PARD is measured with an AC coupling mode, 5cm wires, and in parallel with 0.1 μF ceramic capacitor & 47 μF electrolytic capacitor.

Model Number	DRS-5V50W1A□	DRS-5V50W1N□
--------------	--------------	--------------

Mechanical

Case Cover / Chassis	Plastic	
Dimensions (L x W x D)	75 x 30 x 89.5 mm (2.95 x 1.18 x 3.52 inch)	
Unit Weight	0.16 kg (0.35 lb)	
Indicator	Green LED	DC OK
Cooling System	Convection	
Terminal	Input	3 Pins (Rated 300 V/16 A)
	Output	4 Pins (Rated 300 V/16 A)
Wire	Input / Output	AWG 22-12 / AWG 18-12
Mounting Rail	Standard TS35 DIN Rail in accordance with EN 60715	
Noise (1 Meter from power supply)	Sound Pressure Level (SPL) < 25 dBA	

Environment

Surrounding Air Temperature	Operating	-20°C to +70°C (Cold start at -40°C @ 40% load)
	Storage	-40°C to +85°C
Power De-rating	-10°C to -20°C de-rate power by 2% / °C > 55°C de-rate power by 3.33% / °C	
Operating Humidity	5 to 95% RH (Non-Condensing)	
Operating Altitude	0 to 2,000 Meters (6,560 ft.)	
Shock Test	Non-Operating	IEC 60068-2-27, Half Sine Wave: 50G for a duration of 11 ms; 3 times per direction, 9 times in total
	Operating	IEC 60068-2-27, Half Sine Wave: 10G for a duration of 11 ms; 1 time in X axis
Vibration	Non-Operating	IEC 60068-2-6, Random: 5-500 Hz; 2.09 G _{rms} , 20 min per axis for all X, Y, Z directions
	Operating	IEC 60068-2-6, Sine Wave: 10-500 Hz; 2G peak; displacement of 0.35 mm; 1 octave per min; 60 min per axis for all X, Y, Z directions
Over Voltage Category	II	
Pollution Degree	2	

Protections

Overvoltage	< 7.245 V, SELV Output, Latch Mode
Overload / Overcurrent	105~125% of rated load current, Foldback Mode (continuous current, voltage drops), Auto-recovery when the fault is removed
Over Temperature	< 75°C Surrounding Air Temperature @ 100% load, Latch Mode
Short Circuit	Hiccup Mode, Non-Latching (Auto-recovery when the fault is removed)
Internal Fuse at L pin	T3.15 A
Degree of Protection	IP20
Protection Against Shock	Class I with PE* connection

*PE: Primary Earth

Model Number	DRS-5V50W1A□	DRS-5V50W1N□
--------------	--------------	--------------

Reliability Data

MTBF	Telcordia SR-332	> 700,000 hrs, I/P: 115 Vac & 230 Vac, O/P: 100% load, Ta: 25°C
	MIL-HDBK-217F	165,300 hrs, I/P: 115 Vac & 230 Vac, O/P: 100% load, Ta: 25°C
Expected Cap Life Time		10 years (115 ac & 230 Vac, 50% load @ 40°C)

Safety Standards / Directives

Safety Entry Low Voltage		SELV (IEC 60950)
Electrical Safety	TUV Bauart	EN 62368-1
	UL/cUL recognized	UL 60950-1 and CSA C22.2 No. 60950-1 (File No. E191395) UL 62368-1 and CSA C22.2 No. 62368-1 (File No. E191395)
	CB Scheme	IEC 60950-1, IEC 62368-1, Limited Power Source (LPS, for DRS-5V50WN□ only)
	UKCA	BS EN 62368-1
Industrial Control Equipment	UL/cUL listed	UL 508 and CSA C22.2 No. 107.1-01 (File No. E315335)
Class 2 Power Supply	UL/cUL recognized	UL 60950-1, UL 62368-1, CSA C22.2 No. 60950-1 (File No. E191395) (for DRS-5V50WN□ only)
CE		In conformance with EMC Directive 2014/30/EU and Low Voltage Directive 2014/35/EU
UKCA		In conformance with Electrical Equipment (Safety) Regulations 2016 No. 1011 and The Electromagnetic Compatibility Regulations 2016 No. 1091
Galvanic Isolation	Input to Output	3.0 KVac
	Input to Ground	3.0 KVac
	Output to Ground	0.5 KVac

Model Number		DRS-5V50W1A□	DRS-5V50W1N□
EMC			
Emissions (CE & RE)		Generic Standards: EN/BS EN 61000-6-3, EN/BS EN 61000-6-4, CISPR 32, EN/BS EN 55032, EN/BS EN 55011, FCC Title 47: Class B	
Component Power Supply for General Use		EN 61204-3	
Immunity		Generic Standards: EN/BS EN 55024, EN/BS EN 61000-6-1, EN/BS EN 61000-6-2	
Electrostatic Discharge	IEC 61000-4-2	Level 3 Criteria A ¹⁾ Air Discharge: 8 kV Contact Discharge: 6 kV	
Radiated Field	IEC 61000-4-3	Level 3 Criteria A ¹⁾ 80 MHz-1 GHz, 10 V/M with 1 kHz tone / 80% modulation 1.4 GHz-2 GHz, 3 V/M with 1 kHz tone / 80% modulation 2 GHz-2.7 GHz, 1 V/M with 1 kHz tone / 80% modulation	
Electrical Fast Transient / Burst	IEC 61000-4-4	Level 3 Criteria A ¹⁾ 2 kV	
Surge	IEC 61000-4-5	Level 3 Criteria A ¹⁾ Common Mode ³⁾ : 2 kV Differential Mode ⁴⁾ : 1 kV	
Conducted	IEC 61000-4-6	Level 3 Criteria A ¹⁾ 150 kHz-80 MHz, 10 Vrms	
Power Frequency Magnetic Fields	IEC 61000-4-8	Criteria A ¹⁾ 30 A/Meter	
Voltage Dips and Interruptions	IEC 61000-4-11	0% of 100 Vac, 0 Vac, 20 ms 0% of 100 Vac, 0 Vac, 5000 ms 40% of 100 Vac, 40 Vac, 100 ms 70% of 100 Vac, 70 Vac, 500 ms 0% of 240 Vac, 0 Vac, 20 ms 0% of 240 Vac, 12 Vac, 5000 ms 40% of 240 Vac, 96 Vac, 200 ms 70% of 240 Vac, 168 Vac, 500 ms	Criteria A ¹⁾ Criteria B ²⁾ Criteria B ²⁾ Criteria A ¹⁾ Criteria A ¹⁾ Criteria B ²⁾ Criteria A ¹⁾ Criteria A ¹⁾
Low Energy Pulse Test (Ring Wave)	IEC 61000-4-12	Level 3 Criteria A ¹⁾ Common Mode ³⁾ : 2 kV Differential Mode ⁴⁾ : 1 kV	
Harmonic Current Emission		IEC/EN/BS EN 61000-3-2, Class A	
Voltage Fluctuation and Flicker		IEC/EN/BS EN 61000-3-3	

1) Criteria A: Normal performance within the specification limits
2) Criteria B: Temporary degradation or loss of function which is self-recoverable
3) Asymmetrical: Common mode (Line to earth)
4) Symmetrical: Differential mode (Line to line)

Block Diagram

DRS-5V50W1□Z

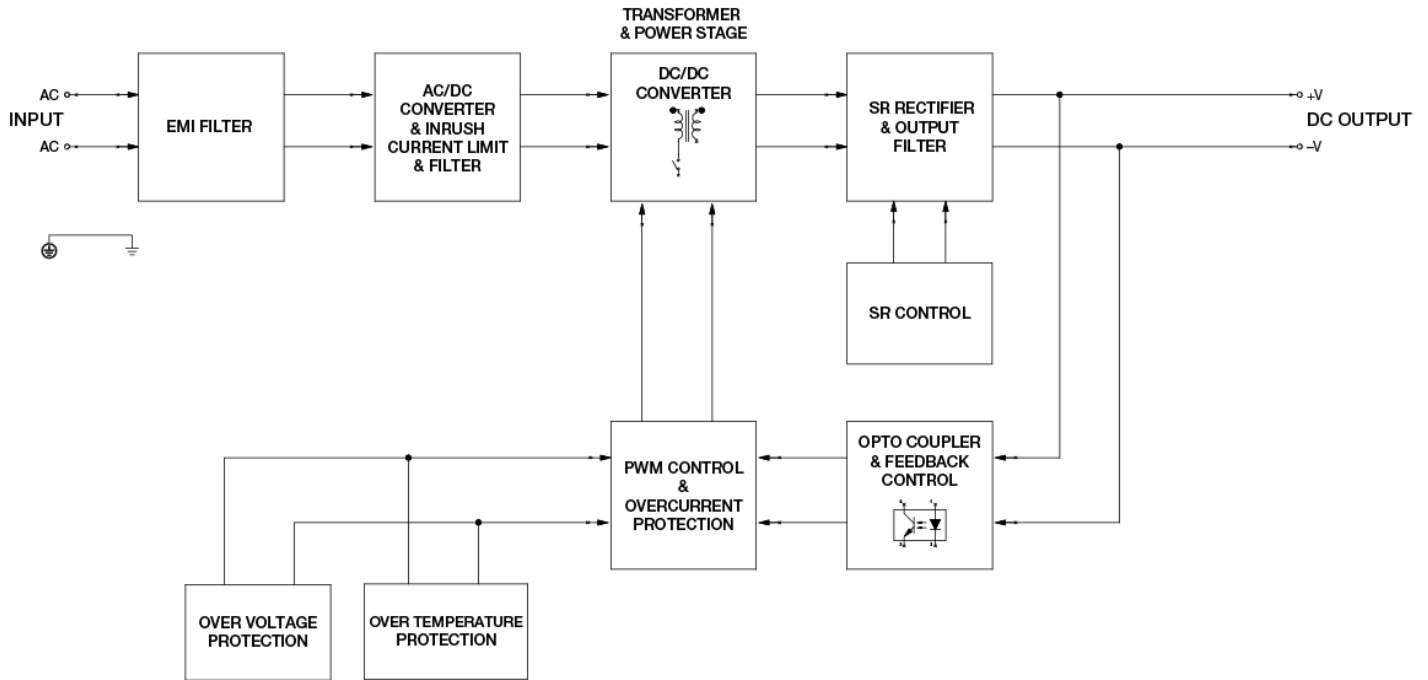

DRS-5V50W1□R

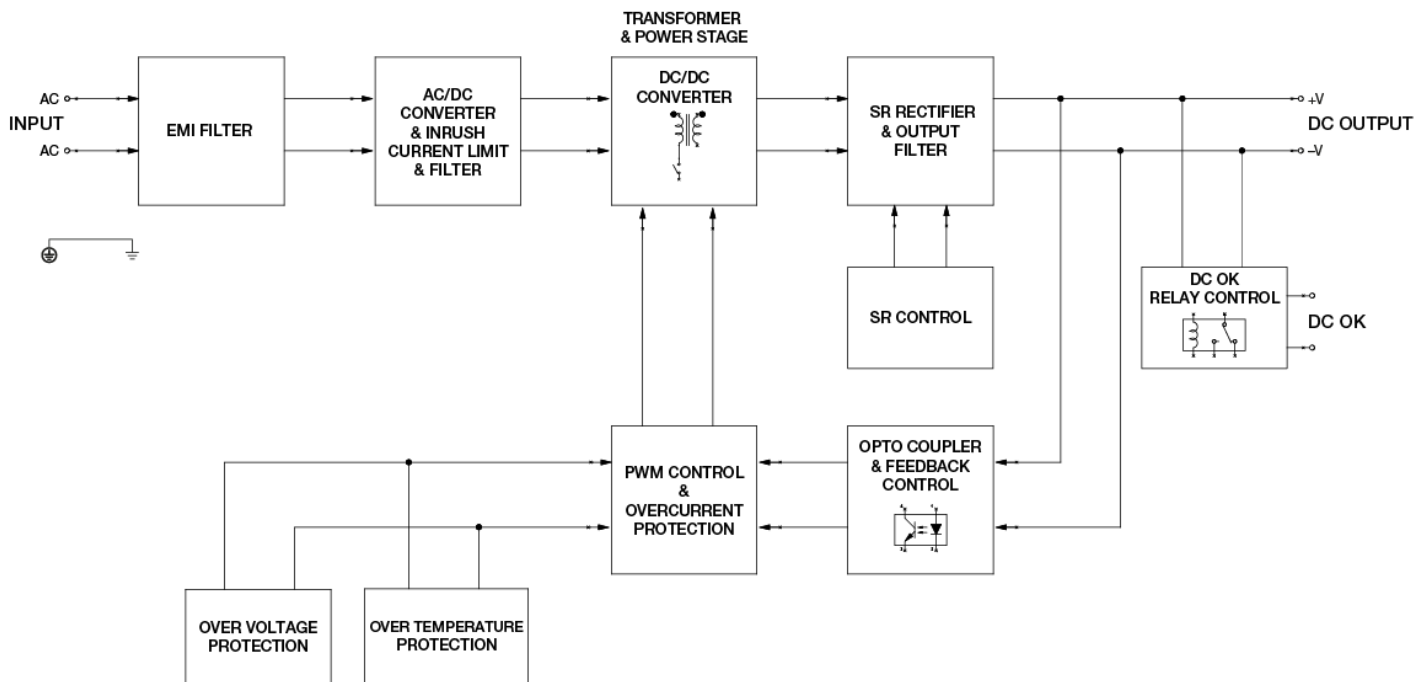

Device Description

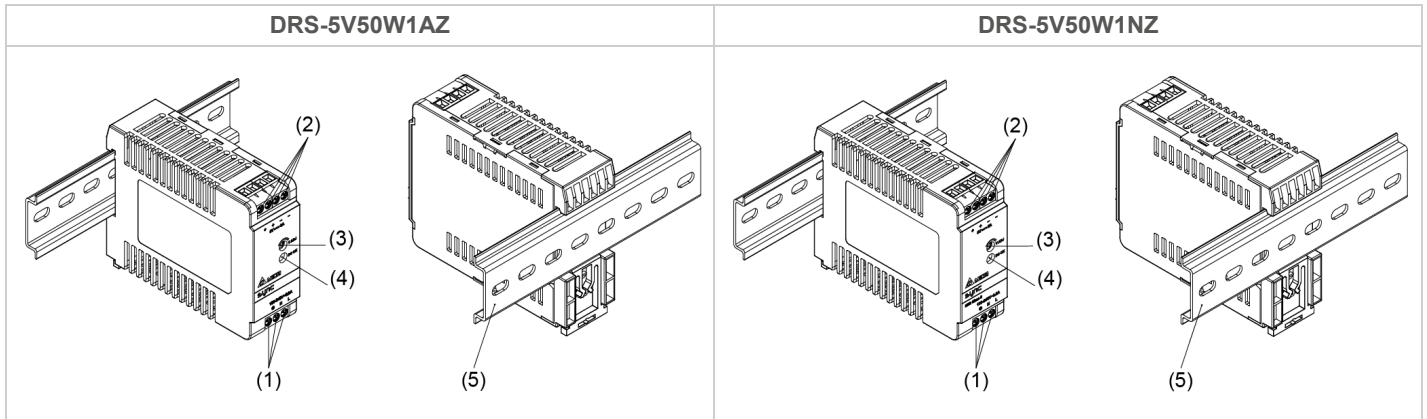

- 1) Input terminal block connector
- 2) Output terminal block connector
- 3) DC voltage adjustment potentiometer
- 4) DC OK LED (Green)
- 5) Universal mounting system

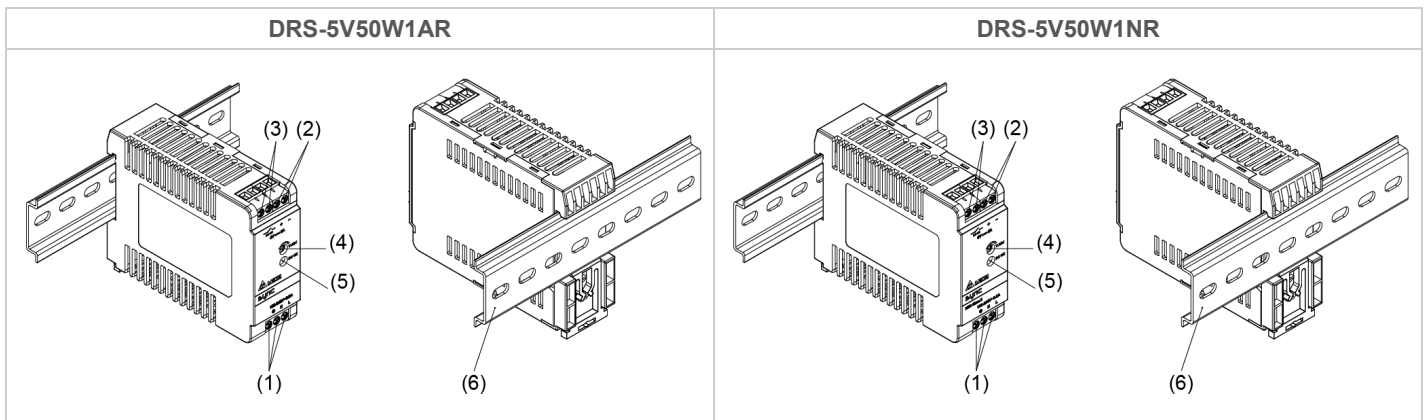

- 1) Input terminal block connector
- 2) Output terminal block connector
- 3) DC OK relay contact
- 4) DC voltage adjustment potentiometer
- 5) DC OK LED (Green)
- 6) Universal mounting system

Dimensions

- **DRS-5V50W1AZ**
 L x W x D: 75 x 30 x 89.5 mm [2.95 x 1.18 x 3.52 inch]

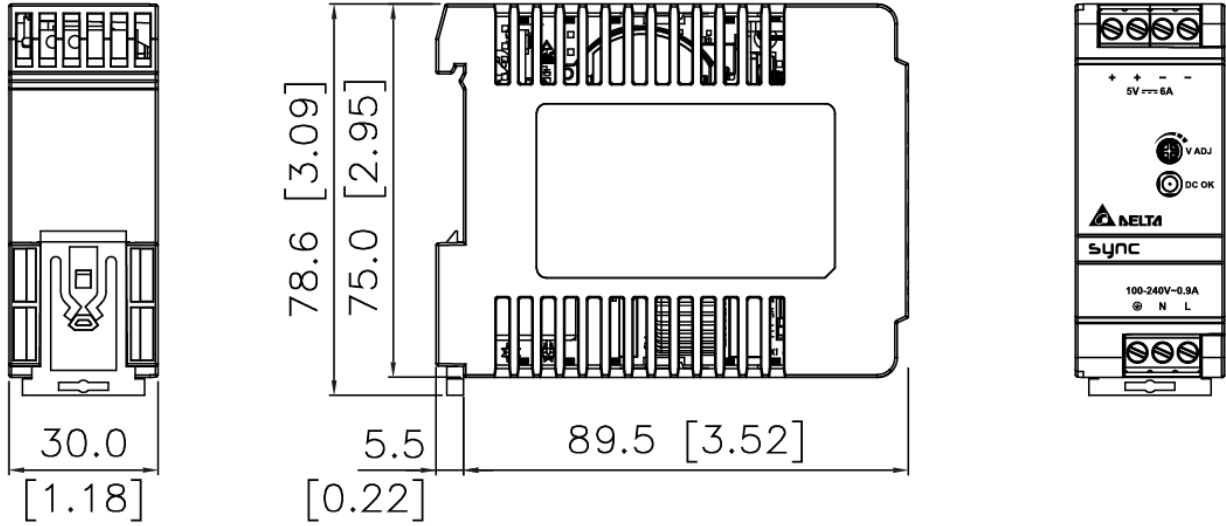

- **DRS-5V50W1AR**
 L x W x D: 75 x 30 x 89.5 mm [2.95 x 1.18 x 3.52 inch]

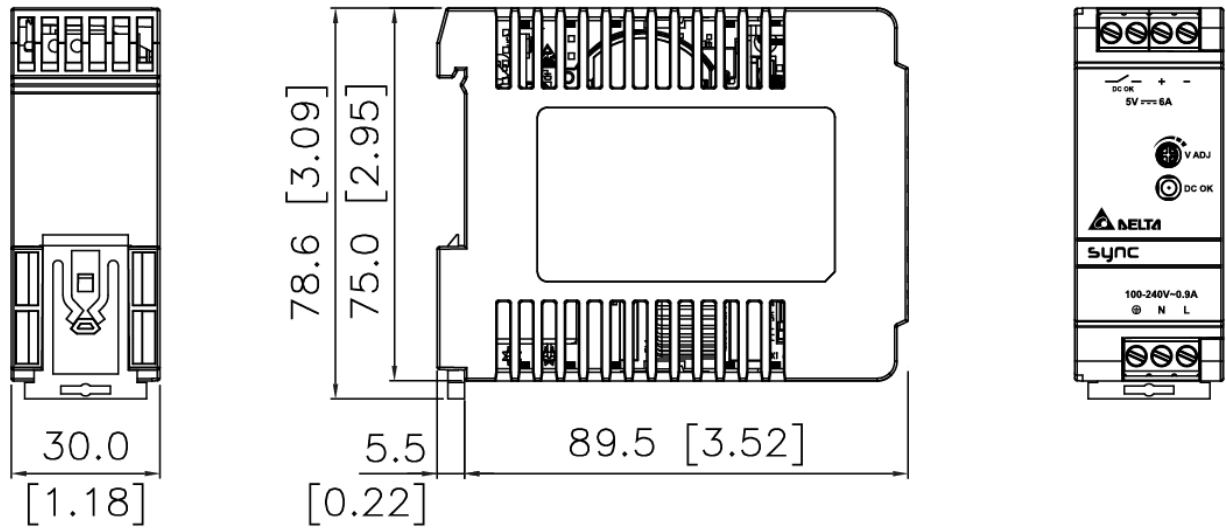

- **DRS-5V50W1NZ**
 L x W x D: 75 x 30 x 89.5 mm [2.95 x 1.18 x 3.52 inch]

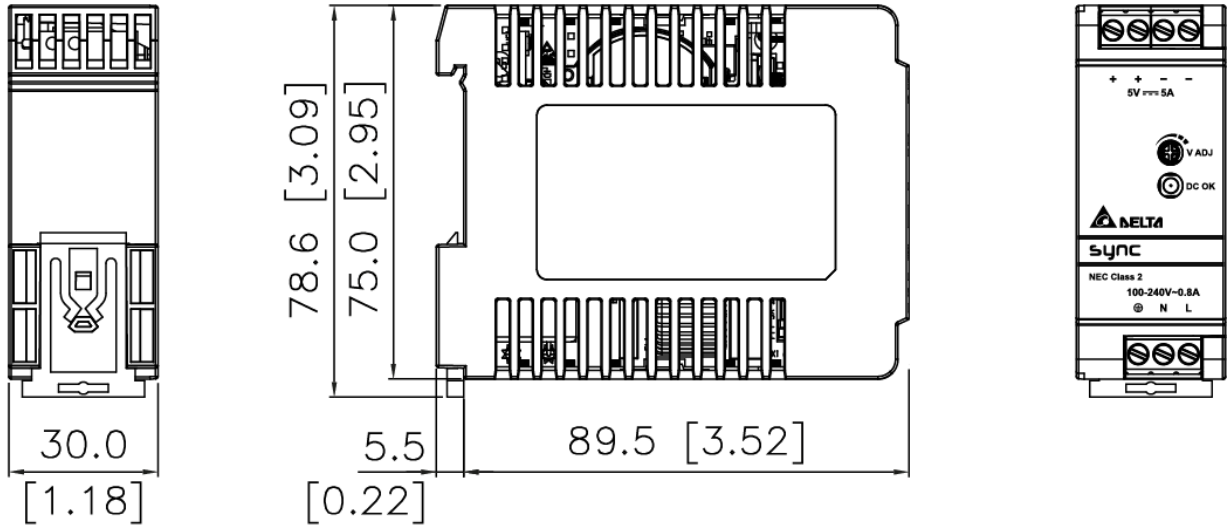

- **DRS-5V50W1NR**
 L x W x D: 75 x 30 x 89.5 mm [2.95 x 1.18 x 3.52 inch]

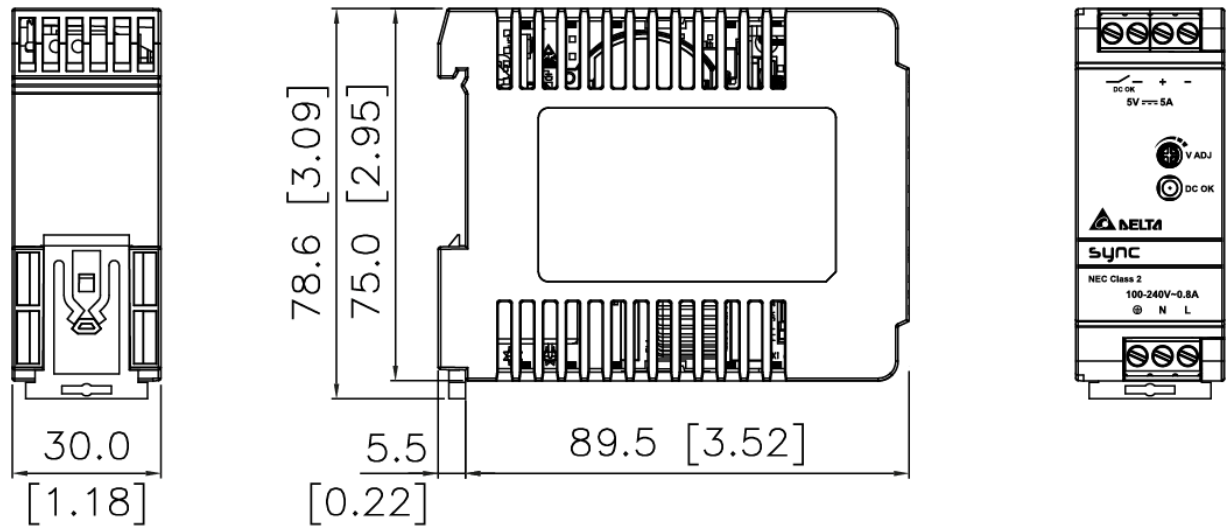

Engineering Data

Output Load De-rating VS Surrounding Air Temperature

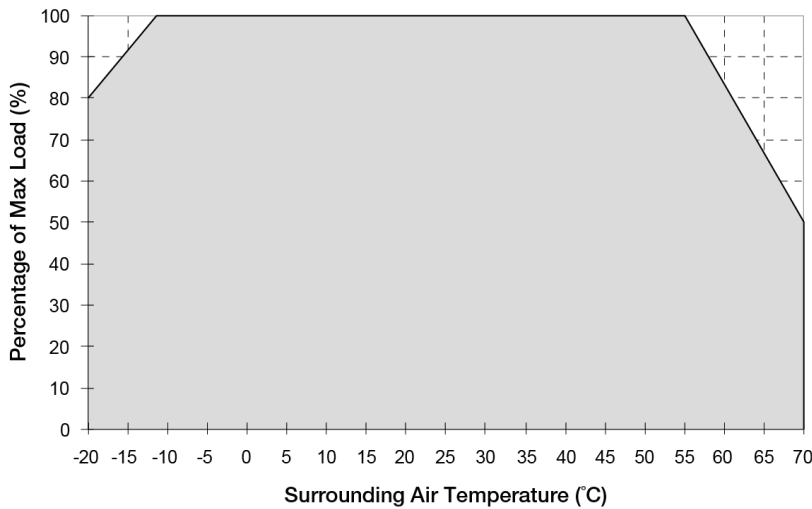
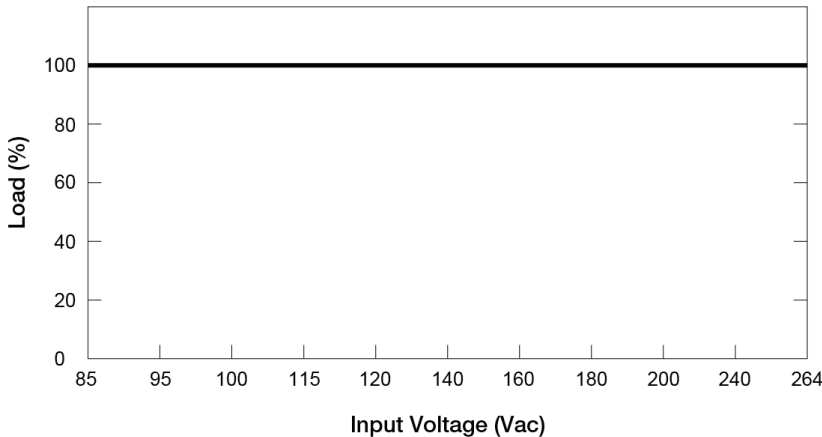

Fig. 1 De-rating for Vertical Mounting Orientation
 -10°C to -20°C de-rate power by 2% / °C
 > 55°C de-rate power by 3.33% / °C

Note

1. Power supply components may degrade, or be damaged, when the power supply is continuously used outside the shaded region, refer to the graph shown in Fig. 1.
2. If the output capacity is not reduced when the surrounding air temperature exceeds its specification as defined on Page 3 under "Environment", the device will run into Over Temperature Protection. When activated, power supply will latch off, until the surrounding air temperature is lowered or the load is reduced as far as necessary to keep the device in working condition, and require removal/re-application of input AC voltage in order to restart.
3. In order for the device to function in the manner intended, it is also necessary to keep a safety distance as recommended in the safety instructions while the device is in operation.
4. Depending on the surrounding air temperature and output load delivered by the power supply, the device can be very hot!
5. If the device has to be mounted in any other orientation, please contact info@deltapsu.com for more details.

Output Load De-rating VS Input Voltage



- No output power de-rating across the entire input voltage range

Assembly & Installation

The power supply unit (PSU) can be mounted on 35mm DIN rails in accordance with EN60715. The device should be installed with input terminal block at the bottom.

Each device is delivered ready to install.

Mounting

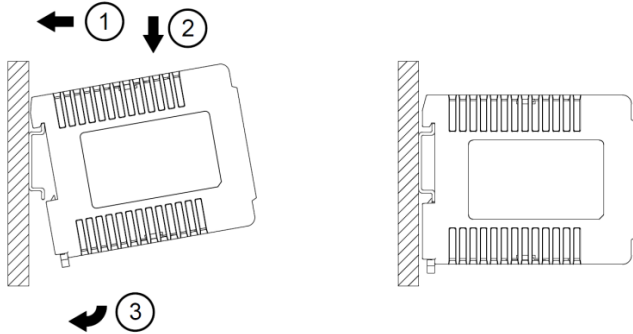

Fig. 2.1 Mounting

Snap on the DIN rail as shown in Fig. 2.1:

1. Tilt the unit slightly upwards and put it onto the DIN rail.
2. Push downwards until stopped.
3. Press against the bottom front side for locking.
4. Shake the unit slightly to ensure that it is secured.

Dismounting

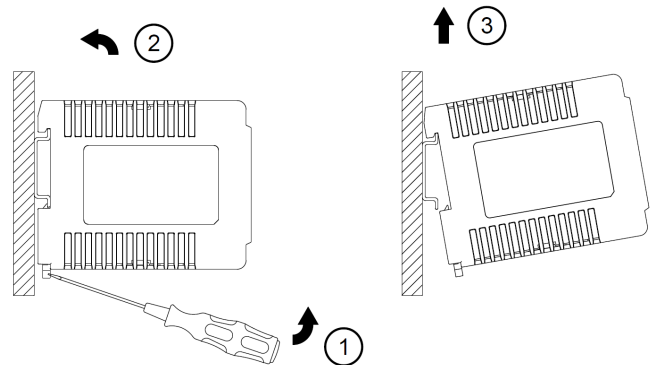
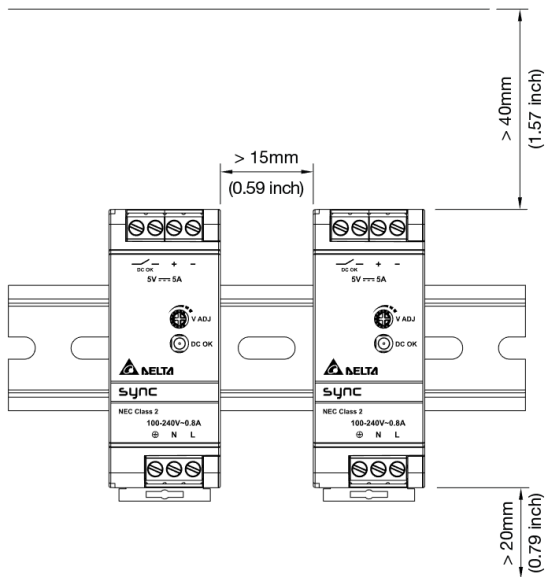

Fig. 2.2 Dismounting

To uninstall, pull or slide down the latch with screw driver as shown in Fig. 2.2. Then slide the power supply unit (PSU) in the opposite direction, release the latch and pull out the power supply unit (PSU) from the rail.

Safety Instructions



- ALWAYS switch mains of input power OFF before connecting and disconnecting the input voltage to the device. If mains are not turned OFF, there is risk of explosion / severe damage.
- **To guarantee sufficient convection cooling, keep a distance of > 40 mm (1.57 inch) above and > 20 mm (0.79 inch) below the device as well as a lateral distance of > 15 mm (0.59 inch) to other units. In case the adjacent device is a heat source, the lateral distance will be > 25 mm (0.98 inch).**
- Note that the enclosure of the device can become very hot depending on the surrounding air temperature and output load connected to the device. Risk of burns!
- The main power must be turned off before connecting or disconnecting the wires to the terminals!
- DO NOT insert any objects into the device.
- Dangerous voltages present for at least 5 minutes after disconnecting all sources of power.
- The power supplies unit should be installed in minimum IP54 rated enclosure.
- The power supplies are built in units and must be installed in a cabinet or room (condensation free environment and indoor location) that is relatively free of conductive contaminants.

(November 2021, Rev. 05)

Functions

- Graph illustrating the Start-up Time, Rise Time, and Hold-up Time

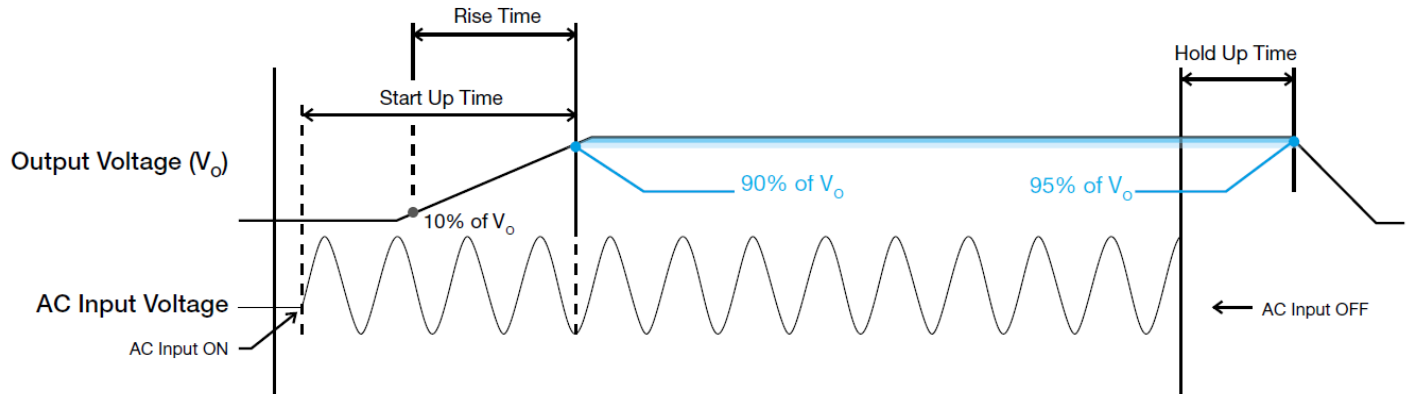

Start-up Time

The time required for the output voltage to reach 90% of its final steady state set value, after the input voltage is applied.

Rise Time

The time required for the output voltage to change from 10% to 90% of its final steady state set value.

Hold-up Time

Time between the collapse of the AC input voltage, and the output falling to 95% of its steady state set value.

Inrush Current

Inrush current is the peak, instantaneous, input current measured and, occurs when the input voltage is first applied. For AC input voltages, the maximum peak value of inrush current will occur during the first half cycle of the applied AC voltage. This peak value decreases exponentially during subsequent cycles of AC voltage.

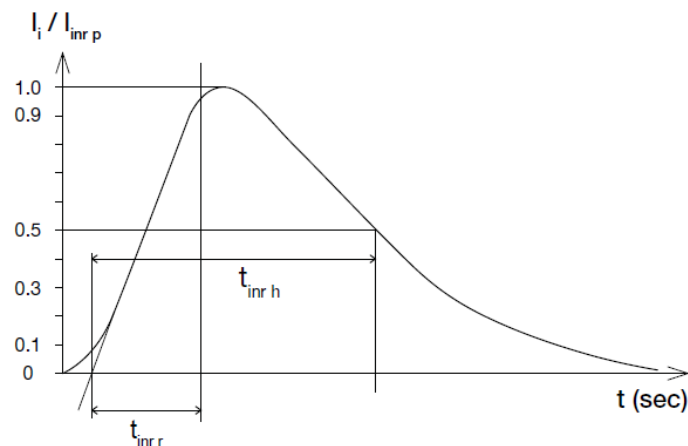

Dynamic Response

The power supply output voltage will remain within $\pm 5\%$ of its steady state value, when subjected to a dynamic load from 0% to 100% of its rated current.

- 50% duty cycle / 5 Hz to 1 KHz

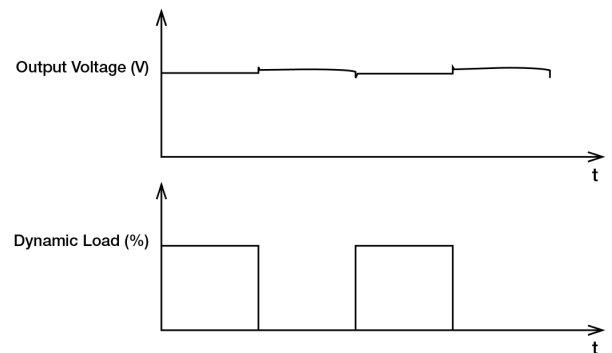

(November 2021, Rev. 05)

Overload & Overcurrent Protections (Auto-Recovery)

The power supply's Overload (OLP) and Overcurrent (OCP) Protections will be activated when output current is about 6.0 A typ. for DRS-5V50W1N□ and 6.7 A typ. for DRS-5V50W1A□. When this occurs, the V_o will start to droop (refer to **A** below). Once the output voltage is below about 1.4 Vdc typ., the power supply will start to operate in "Hiccup mode" (Auto-Recovery mode). The power supply will recover once the fault condition of the OCP is removed and output current is back within the specifications.

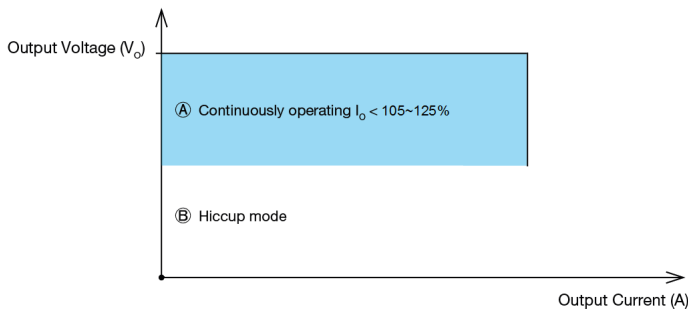

Short Circuit Protection (Auto-Recovery)

The power supply's output Short Circuit Protection function also provides protection against short circuits. When a short circuit is applied, the output current will operate in "Hiccup mode". The power supply will return to normal operation after the short circuit is removed.

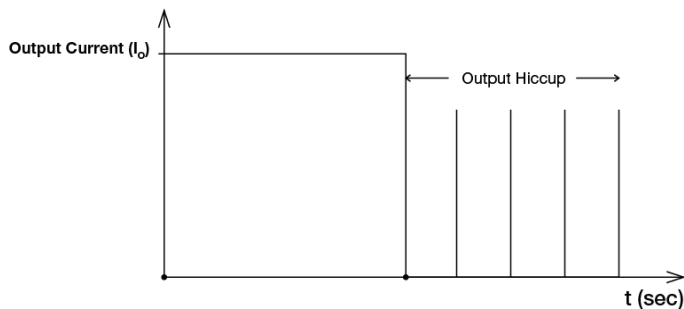

External Input Protection Device

The unit is protected with internal fuse (not replaceable) at L pin and it has been tested and approved on 20 A (UL) and 16 A (IEC) branch circuits without additional protection device. An external protection device is only required if the supplying branch has an ampacity greater than above. Thus, if an external protective device is necessary, or, utilized, a minimum value of 20 A B- or 10 A C- characteristic breaker should be used.

Overvoltage Protection (Latch Mode)

The power supply's overvoltage circuit will be activated when its internal feedback circuit fails. The output voltage shall not exceed its specifications defined on Page 3 under "Protections". Power supply will latch off, and require removal/re-application of input AC voltage in order to restart.

The power supply should be latch.

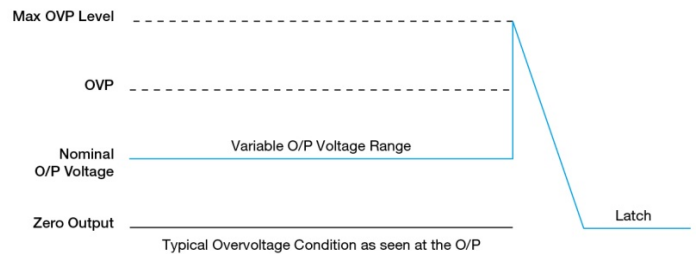

Over Temperature Protection (Latch Mode)

As described in load de-rating section, the power supply also has Over Temperature Protection (OTP). In the event of a higher operating temperature at 100% load; or, when the operating temperature is beyond what is recommended in the de-rating graph, the OTP circuit will be activated. When activated, power supply will latch off, until the surrounding air temperature drops to its normal operating temperature or the load is reduced as recommended in the de-rating graph. Removal/re-application of input AC voltage will then be required in order to restart.