



Highlights & Features

- Universal AC input voltage range
- Power will not de-rate for the entire input voltage range
- High Efficiency > 90.0%
- Power Boost of 150% for 5 seconds and 200% for 2 seconds
- Full corrosion resistant aluminium casing
- Extreme low temperature cold start at -40°C
- Conformal coating on PCBAs to protect against common dust and chemical pollutants
- Hazardous Locations approval to ATEX and Class I, Div 2 (DRP024V480W1BA)
- Certified according to IEC/EN/UL 62368-1

Safety Standards



CB Certified for worldwide use

Model Number: DRP024V480W1B□
Unit Weight: 1.37 kg (3.02 lb)
Dimensions (L x W x D): 121 x 144 x 118.6 mm
 (4.76 x 5.67 x 4.67 inch)

General Description

The CliQ II DIN rail power supply series from one of the world's leading power supply companies, Delta Electronics Group, offers output voltage of 24 V. These products are encased in rugged yet lightweight full aluminium body that can withstand shock and vibration according to IEC 60068-2 standard. The DRP024V480W1B□ can operate over a wide temperature range of -25°C to +75°C. The series of single phase products also features universal AC input voltage range from 85 Vac to 264 Vac and the power will not de-rate throughout the entire range. Another great feature is the conformal coating on the PCBA which allows selected models to be certified to ATEX and Class I, Div 2 for use in hazardous locations. The design conforms to harmonic current emission IEC/EN 61000-3-2, Class A.

Model Information

CliQ II DIN Rail Power Supply

Model Number	Input Voltage Range	Rated Output Voltage	Rated Output Current
DRP024V480W1B□	85-264 Vac (120-375 Vdc)	24 Vdc	20.0 A

Model Numbering

DR	P	024V	480W	1	B	□
DIN Rail	Power Supply	Output Voltage	Output Power	Single Phase	CliQ II Series	A - Metal Case, with Class I, Div 2 N - Metal Case, without Class I, Div 2

(October 2021, Rev. 09)

Specifications

Input Ratings / Characteristics

Nominal Input Voltage	100-240 Vac	
Input Voltage Range	85-264 Vac	
Nominal Input Frequency	50-60 Hz	
Input Frequency Range	47-63 Hz	
DC Input Voltage Range*	120-375 Vdc	
Input Current	< 5.00 A @ 115 Vac, < 3.00 A @ 230 Vac	
Efficiency at 100% Load	> 91.0% @ 115 Vac, > 92.0% @ 230 Vac	
Max Power Dissipation	0% load	< 2.9 W @ 115 Vac, < 2.7W @ 230 Vac
	100% load	< 47 W @ 115 Vac, < 41W @ 230 Vac
Max Inrush Current (Cold Start)	< 35 A @ 115 Vac & 230 Vac	
Power Factor	> 0.96 @ 115 Vac, > 0.95 @ 230 Vac	
Leakage Current	< 3 mA @ 240 Vac	

*Fulfills the test conditions for DC input. DC input safety approval can be obtained upon request.

Output Ratings / Characteristics**

Nominal Output Voltage	24Vdc
Factory Set Point Tolerance	24Vdc \pm 2%
Output Voltage Adjustment Range	24-28 Vdc
Output Current	20.0 A (continuously operating at 24 V) 30.0 A (Power Boost for 5 seconds at 24 V, refer to the details in the Functions section) 40.0 A (Power Boost for 2 seconds at 24 V, refer to the details in the Functions section)
Output Power	480 W (continuously operating at 24 V) 720 W (Power Boost for 5 seconds at 24 V, refer to the details in the Functions section) 960 W (Power Boost for 2 seconds at 24 V, refer to the details in the Functions section)
Line Regulation	< 0.5% (@ 85-264 Vac input, 100% load)
Load Regulation	< 1.0% (@ 85-264 Vac input, 0-100% load)
PARD*** (20 MHz)	< 150 mVpp
Rise Time	< 100 ms @ nominal input (100% load)
Start-up Time	< 1,000 ms @ nominal input (100% load)
Hold-up Time	> 20 ms @ 115Vac & 230Vac (100% load)
Dynamic Response (Overshoot & Undershoot O/P Voltage)	\pm 5% @ 85-264 Vac input, 10-100% load (Slew Rate: 0.1A/ μ s, 50% duty cycle @ 5Hz)
Start-up with Capacitive Loads	10,000 μ F Max

**For power de-rating from 50°C to 75°C, see power de-rating on page 3.

***PARD is measured with an AC coupling mode, 5 cm wires, and in parallel with 0.1 μ F ceramic capacitor & 47 μ F electrolytic capacitor.

Mechanical

Case Cover / Chassis	Aluminium	
Dimensions (L x W x D)	121 x 144 x 118.6 mm (4.76 x 5.67 x 4.67 inch)	
Unit Weight	1.37 kg (3.02 lb)	
Indicator	Green LED	DC OK
Cooling System	Convection	
Terminal	Input	3 Pins (Rated 300 V/30 A)
	Output	4 Pins (Rated 300 V/30 A)
Wire	Input	AWG 18-10
	Output	AWG 12-10
Mounting Rail	Standard TS35 DIN Rail in accordance with EN 60715	
Noise (1 Meter from power supply)	Sound Pressure Level (SPL) < 40 dBA	

Environment

Surrounding Air Temperature	Operating	-25°C to +75°C (Cold Start at -40°C)
	Storage	-40°C to +85°C
Power De-rating	Vertical Mounting	> 50°C de-rate power by 2.5% / °C, > 70°C de-rate power by 5% / °C
Operating Humidity	5 to 95% RH (Non-Condensing)	
Operating Altitude	0 to 2,500 Meters (8,200 ft)	
Shock Test	Non-Operating	IEC 60068-2-27, 30 G (300m/S ²) for a duration of 18ms, 1 time per direction, 2 times in total
Vibration	Non-Operating	IEC 60068-2-6, 10 Hz to 500 Hz @ 30 m/S ² (3G peak); 60 min per axis for all X, Y, Z direction
Bump Test	Operating	IEC 60068-2-29, Half Sine Wave: 10G for a duration of 11ms, 1,000 times per direction, 6,000 times in total
Over Voltage Category	III	According to IEC/EN 62477-1 / EN 60204-1 (clearance and creepage distances) and IEC 62103 (safety part)
Pollution Degree	2	

Protections

Overvoltage	< 32 V, ±10%, SELV Output, Hiccup Mode, Non-Latching (Auto-Recovery)
Overload / Overcurrent	> 200% of rated load current, Hiccup Mode, Non-Latching (Auto-Recovery)
Over Temperature	< 80°C Surrounding Air Temperature @ 100% load, Non-Latching (Auto-Recovery)
Short Circuit	Hiccup Mode, Non-Latching (Auto-Recovery when the fault is removed)
Internal Fuse at L pin	T 8 A H
Degree of Protection	IP20
Protection Against Shock	Class I with PE* connection

*PE: Primary Earth

Reliability Data

MTBF	> 500,000 hrs. as per Telcordia SR-332 I/P: 115 Vac, O/P: 100% load, Ta: 25°C
Expected Cap Life Time	10 years (115 Vac & 230 Vac, 50% load @ 40°C)

Safety Standards / Directives

Electrical Equipment of Machines	EN/BS EN 60204-1 (over voltage category III)	
Electrical Equipment for Use in Electrical Power Installations	IEC/EN/BS EN 62477-1 / IEC 62103	
Safety Entry Low Voltage	SELV (IEC 60950-1)	
Electrical Safety	SIQ Bauart	EN 62368-1
	UL/cUL recognized	UL 60950-1 and CSA C22.2 No. 60950-1 (File No. E191395) UL 62368-1 and CSA C22.2 No. 62368-1 (File No. E191395)
	CB Scheme	IEC 60950-1, IEC 62368-1
	UKCA	BS EN 62368-1
Industrial Control Equipment	UL/cUL listed	UL 508 and CSA C22.2 No. 107.1-01 (File No. E315355)
	CSA	CSA C22.2 No. 107.1-01 (File No. 181564)
Hazardous Location / ATEX (For DRP024V480W1BA)	cCSAus	CSA C22.2 No. 213-M1987, ANSI / ISA 12.12.01:2007 [Class I, Division 2, Group A, B, C, D T4, Ta= -25°C to +75°C (Vertical: > +50°C derating)]
	ATEX	EN 60079-0:2009, EN 60079-15:2010 [Ex II 3G Ex nA nC IIC T4 Gc, Ta= -25°C to +75°C (Vertical: > +50°C derating)] Certificate No. EPS 12 ATEX 1 491 X
CE	In conformance with EMC Directive 2014/30/EU and Low Voltage Directive 2014/35/EU For DRP024V480W1BA: In conformance with Equipment for explosive atmospheres (ATEX) directive 2014/34/EU	
UKCA	In conformance with Electrical Equipment (Safety) Regulations 2016 No. 1011 and The Electromagnetic Compatibility Regulations 2016 No. 1091	
Galvanic Isolation	Input to Output	4.0 KVac
	Input to Ground	1.5 KVac
	Output to Ground	1.5 KVac

EMC

Emissions (CE & RE)		Generic Standards: CISPR 32, EN/BS EN 55032, KN 32, CISPR 11, EN/BS EN 55011, FCC Title 47: Class B
Component Power Supply for General Use		EN/BS EN 61204-3
Immunity		Generic Standards: EN/BS EN 55024, KN 35, EN/BS EN 61000-6-2
Electrostatic Discharge	IEC 61000-4-2	Level 4 Criteria A ¹⁾ Air Discharge: 15 kV Contact Discharge: 8 kV
Radiated Field	IEC 61000-4-3	Level 3 Criteria A ¹⁾ 80 MHz-1 GHz, 10 V/M, 80% modulation (1 kHz) 1.4 GHz-2 GHz, 3 V/M, 80% modulation (1 kHz) 2 GHz-2.7 GHz, 1 V/M, 80% modulation (1 kHz)
Electrical Fast Transient / Burst	IEC 61000-4-4	Level 3 Criteria A ¹⁾ 2 kV
Surge	IEC 61000-4-5	Level 3 Criteria A ¹⁾ Common Mode ²⁾ : 2 kV Differential Mode ³⁾ : 1 kV
Conducted	IEC 61000-4-6	Level 3 Criteria A ¹⁾ 150 kHz-80 MHz, 10 Vrms
Power Frequency Magnetic Fields	IEC 61000-4-8	Criteria A ¹⁾ 30 A/Meter
Voltage Dips and Interruptions	IEC 61000-4-11	100% dip; 1 cycle (20 ms); Self Recoverable
Low Energy Pulse Test (Ring Wave)	IEC 61000-4-12	Level 3 Criteria A ¹⁾ Common Mode ²⁾ : 2 kV Differential Mode ³⁾ : 1 kV
Harmonic Current Emission		IEC/EN/BS EN 61000-3-2, Class A
Voltage Fluctuation and Flicker		IEC/EN/BS EN 61000-3-3

1) Criteria A: Normal performance within the specification limits
 2) Asymmetrical: Common mode (Line to earth)
 3) Symmetrical: Differential mode (Line to line)

Block Diagram

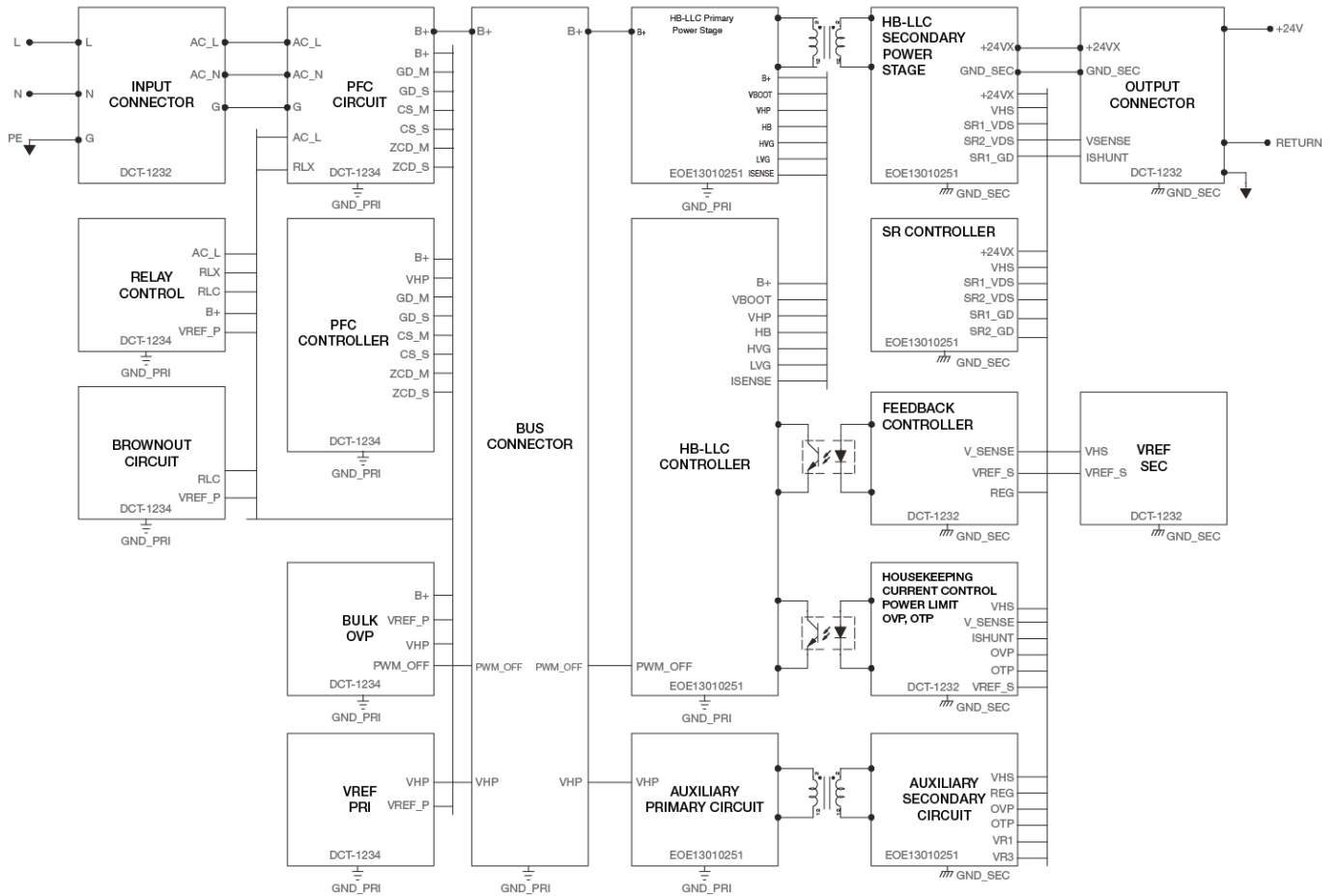

Device Description

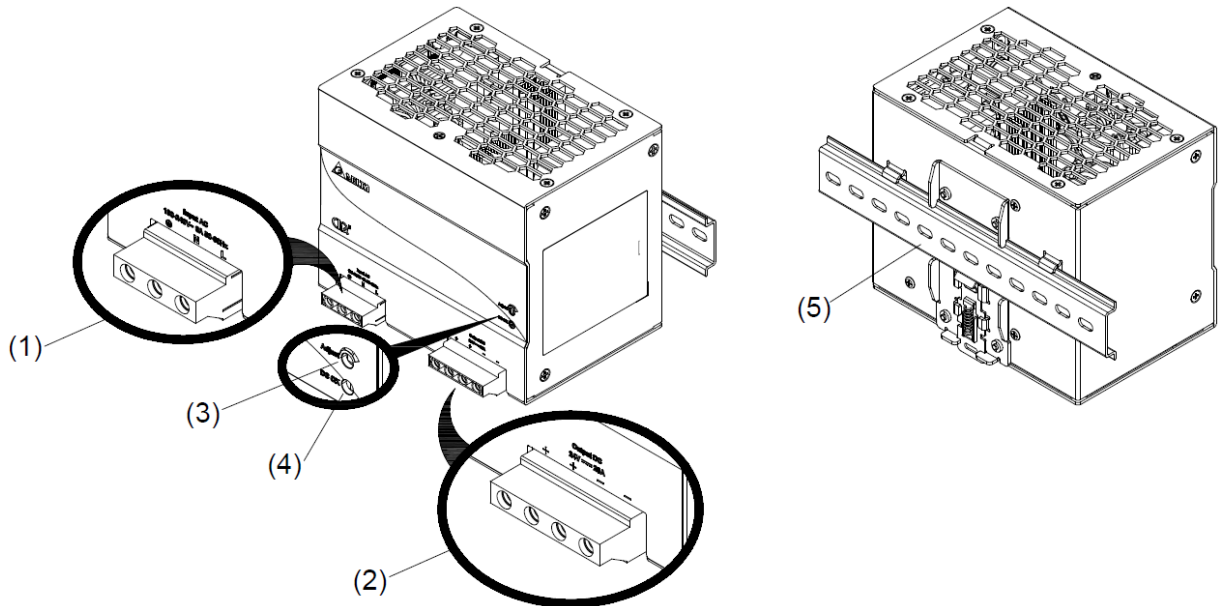

- 1) Input terminal block connector
- 2) Output terminal block connector
- 3) DC Voltage adjustment potentiometer
- 4) DC OK control LED (Green)
- 5) Universal mounting rail system

Dimensions

L x W x D: 121 x 144 x 118.6 mm (4.76 x 5.67 x 4.67 inch)

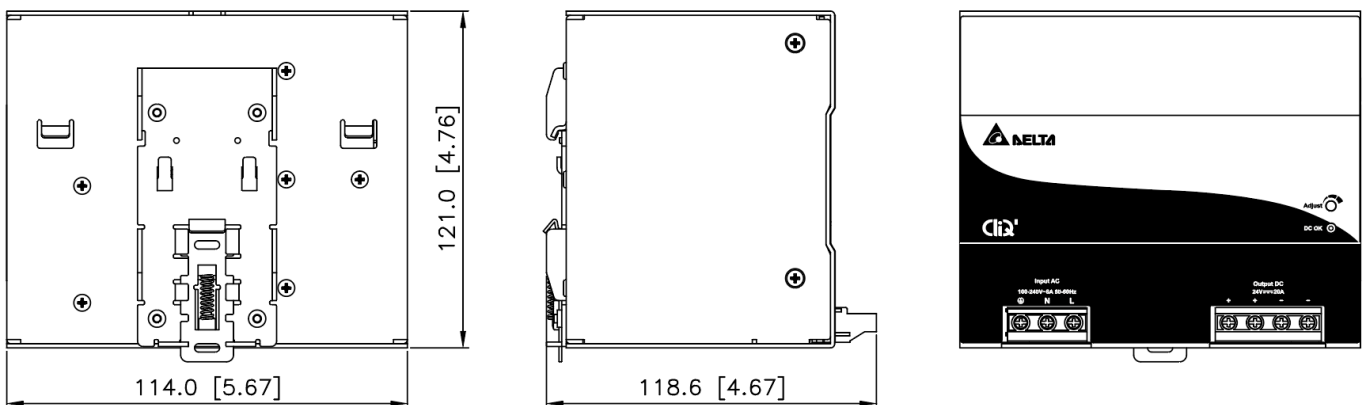

Engineering Data

Output Load De-rating VS Surrounding Air Temperature

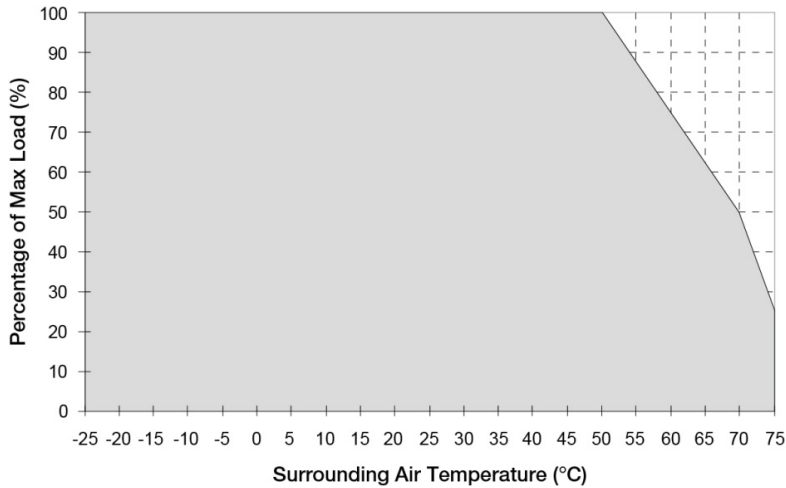
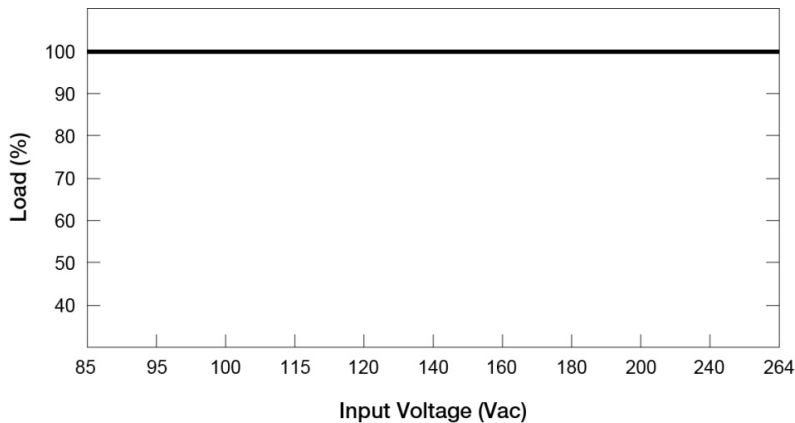

Fig. 1 De-rating for Vertical Mounting Orientation
 > 50°C de-rate power by 2.5% / °C,
 > 70°C de-rate power by 5% / °C

Note

1. Power supply components may degrade, or be damaged, when the power supply is continuously used outside the shaded region, refer to the graph shown in Fig. 1.
2. If the output capacity is not reduced when the surrounding air temperature exceeds its specification as defined on Page 3 under "Environment", the device may run into Over Temperature Protection. When activated, the output voltage will go into bouncing mode and will recover when the surrounding air temperature is lowered or the load is reduced as far as necessary to keep the device in working condition.
3. In order for the device to function in the manner intended, it is also necessary to keep a safety distance as recommended in the safety instruction while the device is in operation.
4. Depending on the surrounding air temperature and output load delivered by the power supply, the device can be very hot!
5. If the device has to be mounted in any other orientation, please contact info@deltapsu.com for more details.

Output Load De-rating VS Input Voltage



- No output power de-rating across the entire input voltage range

Assembly & Installation

The power supply unit (PSU) can be mounted on 35 mm DIN rails in accordance with EN 60715. The device should be installed with input terminal block on the left side.

Each device is delivered ready to install.

Mounting

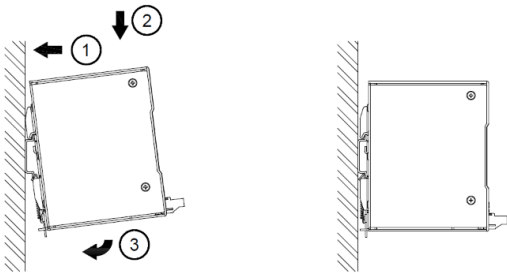

Fig. 2.1 Mounting

Snap on the DIN rail as shown in Fig. 2.1:

1. Tilt the unit upwards and insert it onto the DIN rail.
2. Push downwards until stopped.
3. Press against the bottom front side for locking.
4. Shake the unit slightly to ensure that it is secured.

Dismounting

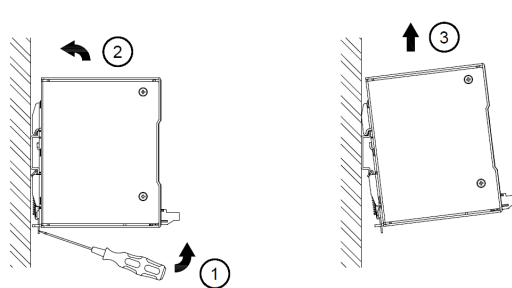

Fig. 2.2 Dismounting

To uninstall, pull or slide down the latch with screw driver as shown in Fig. 2.2. Then slide the power supply unit (PSU) in the opposite direction, release the latch and pull out the power supply unit (PSU) from the rail.

In accordance to EN 60950 / UL 60950 and EN 62368 / UL 62368, flexible cables require ferrules. Use appropriate copper cables designed to sustain operating temperature of:

1. 60°C, 60°C / 75°C for USA
2. At least 75°C for ambient not exceeding 60°C, and 90°C for ambient exceeding 60°C for Canada.

Safety Instructions

■ Vertical Mounting

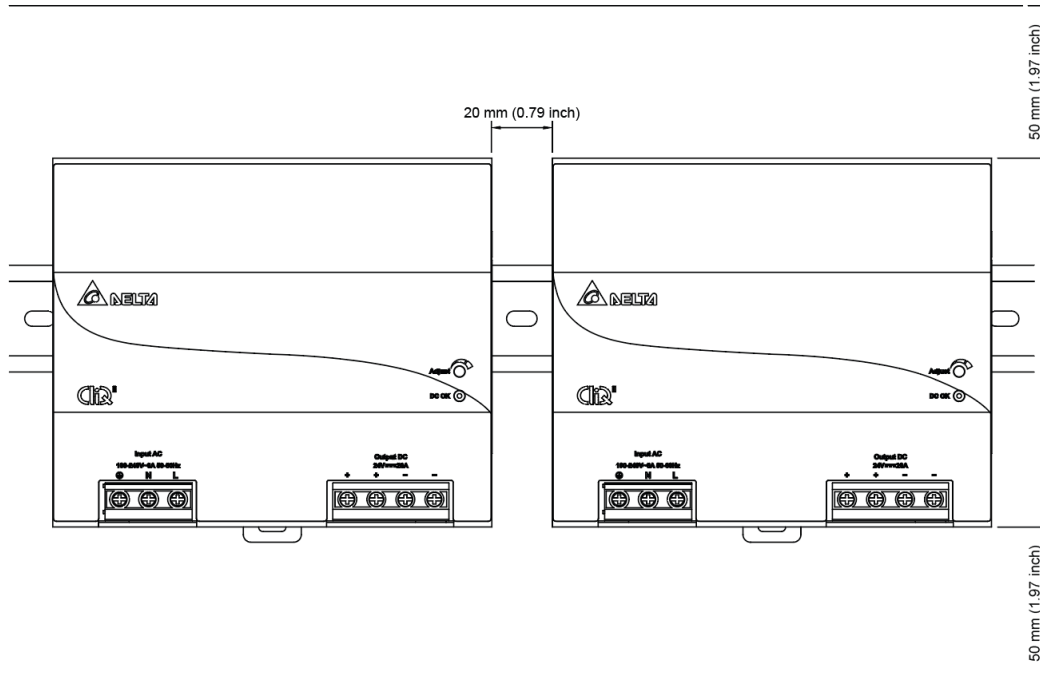

- ALWAYS switch mains of input power OFF before connecting and disconnecting the input voltage to the unit. If mains are not turned OFF, there is risk of explosion / severe damage.
- **To guarantee sufficient convection cooling, keep a distance of 50 mm (1.97 inch) above and below the device as well as a lateral distance of 20 mm (0.79 inch) to other units.**
- Note that the enclosure of the device can become very hot depending on the surrounding air temperature and load of the power supply. Risk of burns!
- Only plug in and unplug connectors when power is turned off!
- DO NOT insert any objects into the unit.
- Hazardous voltages may be present for up to 5 minutes after the input mains voltage is disconnected. Do not touch the unit during this time.
- The power supplies are built in units and must be installed in a cabinet or room (condensation free environment and indoor location) that is relatively free of conductive contaminants.
- CAUTION: "For use in a controlled environment".

For DRP024V480W1BA:

- The power supplies unit must be installed in an IP54 enclosure or cabinet in the final installation. The enclosure or cabinet must comply with EN 60079-0 or EN 60079-15.
- Warning: Explosion Hazard - Substitution of components may impair suitability for Class I, Division 2.
- Warning: Explosion Hazard - Do not disconnect equipment or adjust potentiometer unless the power has been switched off or the area is known to be non-hazardous.

Functions

- Graph illustrating the Start-up Time, Rise Time, and Hold-up Time

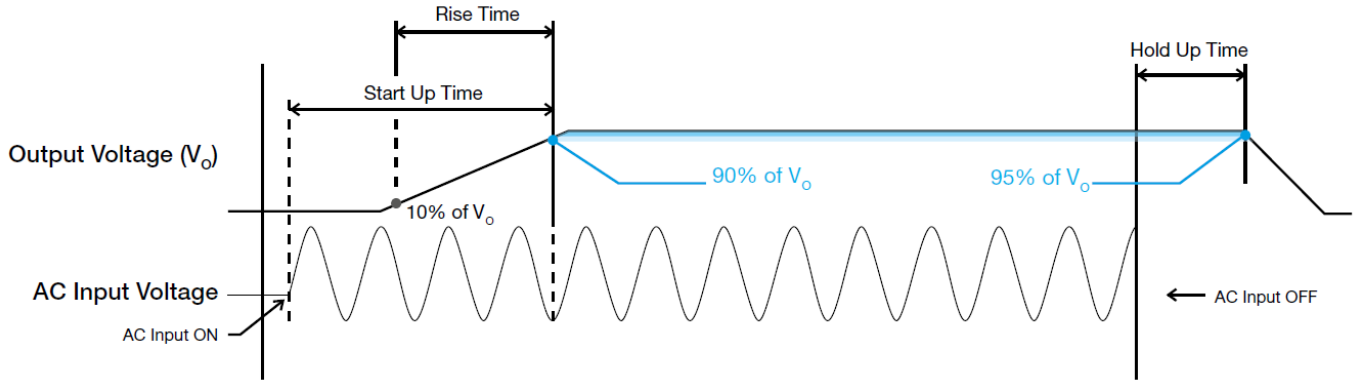

Start-up Time

The time required for the output voltage to reach 90% of its final steady state set value, after the input voltage is applied.

Rise Time

The time required for the output voltage to change from 10% to 90% of its final steady state set value.

Hold-up Time

Time between the collapse of the AC input voltage, and the output falling to 95% of its steady state set value.

Inrush Current

Inrush current is the peak, instantaneous, input current measured and, occurs when the input voltage is first applied. For AC input voltages, the maximum peak value of inrush current will occur during the first half cycle of the applied AC voltage. This peak value decreases exponentially during subsequent cycles of AC voltage.

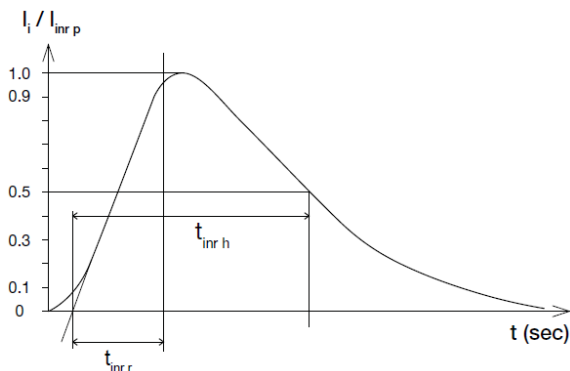

Dynamic Response

The power supply output voltage will remain within $\pm 5\%$ of its steady state value, when subjected to a dynamic load from 10 to 100% of its rated current.

- 50% duty cycle / 5 Hz

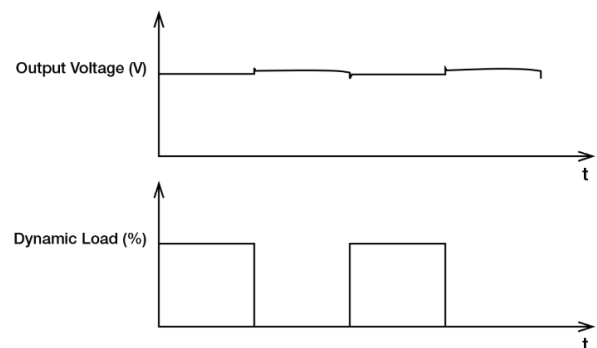

Power Boost

Power Boost is the reserve power available constantly that allows reliable startup to support sudden and short spike of loads with high inrush current typically during turn on to remove the need of more expensive higher rated power supply unit. After the output has reached its steady state set value, the power supply can support surge loads with a higher short-term power demand up to 200% of maximum rated load (I_o Max), for a maximum duration of 2 seconds, or 150% of maximum rated load for a maximum duration of 5 seconds. The Power Boost is also available to repeatedly basis with according to the condition of an average (R.M.S) output power shall not exceed continuous operating condition or refer to duty cycle calculation below.

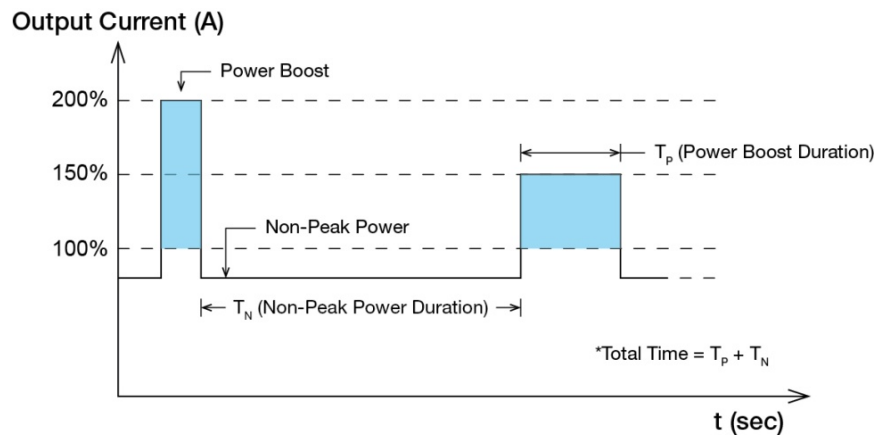

Fig. 3 Duty Cycle Calculation

$$Duty\ cycle\ (\%) = \frac{T_p}{Total\ Time}$$

$$Average\ Output\ Power\ (P_{Avg}) = \frac{(Power\ Boost \times T_p) + (Non-Peak\ Power \times T_N)}{Total\ Time}$$

OR

$$Non-Peak\ Power = \frac{(P_{Avg} \times Total\ Time) - (Power\ Boost \times T_p)}{T_N}$$

■ An example of Power Boost and Average Output Power

Power Boost	Peak Power (W _P)	Power Boost Duration (T _P)	Duty Cycle	Non-Peak Power (W _N)	Non-Peak Power Duration (T _N)	Total Time (T)
200%	960	2 sec	5%	455 W	38 sec	40 sec
150%	720	5 sec	10%	453 W	45 sec	50 sec
150%	720	5 sec	35%	351 W	9.3 sec	14.3 sec
120%	576	10 sec	20%	456 W	40 sec	50 sec
120%	576	10 sec	35%	428 W	18.5 sec	28.5 sec

It is not recommended to prolong the duration of Power Boost to be longer than the specified duty cycle calculation, this may cause damage to the PSU.

External Input Protection Device

The unit is protected at the L pin, with an internal fuse that cannot be replaced. The power supply has been tested and approved on 20 A (UL) and 16 A (IEC) branch circuits without additional protection device. An external protection device is only required if the supplying branch has an ampacity greater than above. Thus, if an external protective device is necessary, or, utilized, please refer a minimum value of 10 A B- or 8 A C- characteristic breaker.

Overload & Overcurrent Protections (Auto-Recovery)

The power supply's Overload (OLP) and Overcurrent (OCP) Protections will be activated when output current (I_o) exceeds its specification as defined on Page 3 under "Protections". In such occurrence, the output voltage (V_o) will start to droop and once the power supply has reached its maximum power limit, the protection is activated and the power supply will go into "Hiccup mode" (Auto-Recovery). The power supply will recover once the fault condition of the OLP and OCP is removed and I_o is back within the specifications.

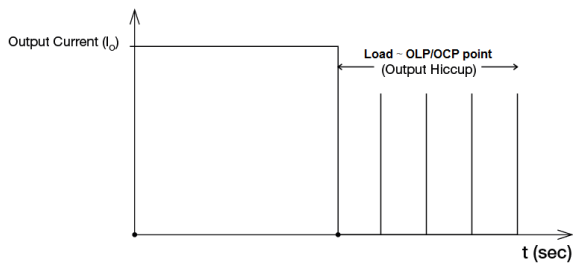

It is not recommended to prolong the duration of I_o when it is less than OLP/OCP point, but greater than 100%, since it may cause damage to the PSU.

Short Circuit Protection (Auto-Recovery)

The power supply's output OLP/OCP function also provides protection against short circuits. When a short circuit is applied, the output current will operate in "Hiccup mode", as shown in the illustration in the OLP/OCP section on this page. The power supply will return to normal operation after the short circuit is removed.

Overvoltage Protection (Auto-Recovery)

The power supply's overvoltage circuit will be activated when its internal feedback circuit fails. The output voltage shall not exceed its specifications defined on Page 3 under "Protections".

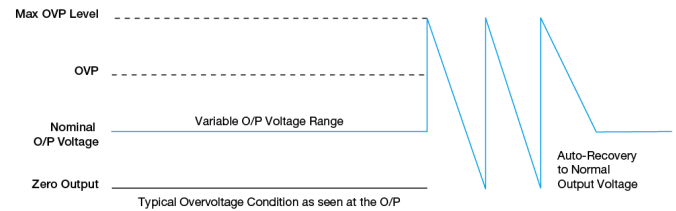

Over Temperature Protection (Auto-Recovery)

As mentioned above, the power supply also has Over Temperature Protection (OTP). In the event of a higher operating temperature at 100% load, the power supply will run into OTP when the operating temperature is beyond what is recommended in the de-rating graph. When activated, the output voltage will go into bouncing mode until the temperature drops to its normal operating temperature as recommended in the de-rating graph.

Operating Mode

■ Redundant Operation

In order to ensure proper redundant operation for the power supply unit (PSU), the output voltage difference between the two units must be kept at 0.45~0.50 V for 24 V supplies. Follow simple steps given below to set them up for the redundant operation:

Step 1.

Measure output voltage of PSU 1 and PSU 2. If PSU 1 is the master unit, then V_O of PSU 1 must be higher than PSU 2. In order to set the output voltage, individually connect the power supply to 50% of rated load at any line voltage from 85-264 Vac, and set the PSU 1 and PSU 2 output voltage.

Step 2.

Connect the power supply units PSU 1 and PSU 2 to Vin 1 & Vin 2, respectively, of the DRR-20N (or 20A) module shown on the diagram on the right.

Step 3.

Connect the system load from V_{out} . Please note that output voltage V_{out} from DRR module will be = V_O (output voltage of power supply) - V_{drop}^* (in DRR module).

* V_{drop} will vary from 0.60 V to 0.90 V (Typical 0.65 V) depending on the load current and surrounding air temperature.

■ Parallel Operation

The power supply units (PSUs) can also be used for parallel operation in order to increase the output power. The difference in output voltage between the two units must be kept to within 25 mV of each other. This difference must be verified with the same output load connected independently to each unit.

Parameters such as EMI, inrush current, leakage current, PARD, start up time will be different from those on the datasheet, when two units are connected in parallel. The user will need to verify that any differences will still allow the two power supplies connected in parallel will work properly in their product/application.

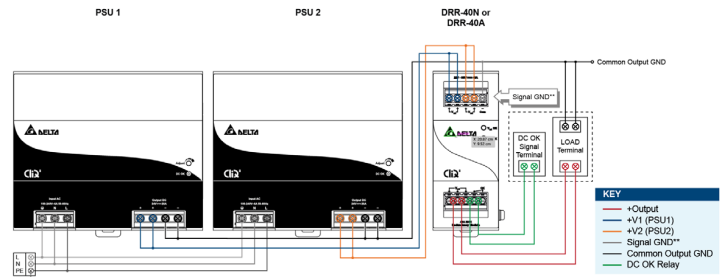

**The Signal GND in the DRR module is for the built-in LED and DC OK signals. The Output GND terminals from the two PSU's do not need to be connected to the Signal GND terminal.

Fig. 4 Redundant Operation Connection Diagram

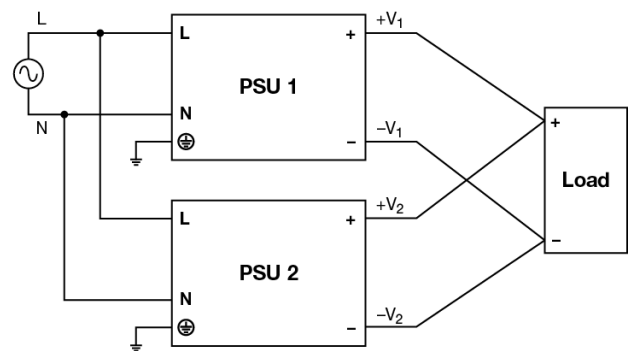

Fig. 5 Parallel Operation Connection Diagram

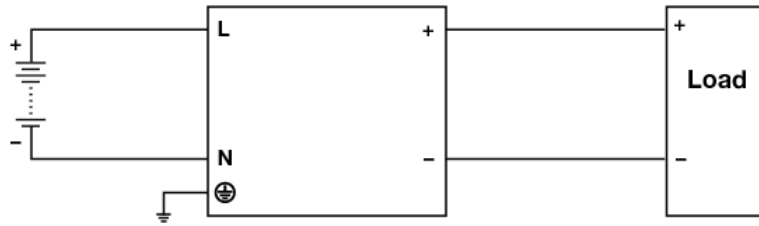

Fig. 6 DC Input Operation Connection Diagram

■ DC Input Operation

Step 1.

Use a battery or similar DC source.

Step 2.

Connect +pole to L and -pole to N.

Step 3.

Connect the PE terminal to an earth wire or to the machine ground.

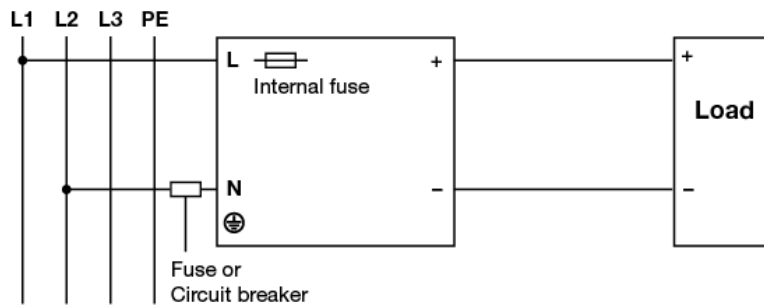

Fig. 7 2 of 3 Phase System Input Operation Connection Diagram

■ 2 of 3 Phase System Input Operation

Delta's CliQ II can use on 2 of 3 phase system. Please refer to the following step.

Step 1.

The input voltage applied from Line to Neutral is below the maximum rated input. The input voltage shall be below 240 Vac +10%.

Step 2.

The external protector is needed on N (Neutral) input line to secure a safety. N line does not have internal fuse protection. An appropriate fuse or circuit breaker should be connected in series with N input line connection like the following.

Others

Conformal Coating

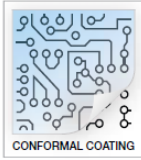

The Protective Coating Technology

Delta Electronics Group has designed the perfect dipping technique which penetrates everywhere including under device, and prevents leakage. The conformal coating dipping can be applied to PCBAs or circuit board. The coating preserves the performance of precision electronic primarily by preventing ionizable contaminants such as salt from reaching circuit nodes, where the material slumps around sharp edges. This can be a problem especially in highly conversing atmosphere.

PFC – Norm EN 61000-3-2



Line Current Harmonic content

Typically, the input current waveform is not sinusoidal due to the periodical peak charging of the input capacitor. In industrial environment, complying with EN 61000-3-2 is only necessary under special conditions. Complying to this standard can have some technical drawbacks, such as lower efficiency as well as some commercial aspects such as higher purchasing costs. Frequently, the user does not profit from fulfilling this standard, therefore, it is important to know whether it is mandatory to meet this standard for a specific application.

(October 2021, Rev. 09)