



Highlights & Features

- Universal AC input voltage range
- Built-in constant current circuit for charging application
- High efficiency of up to 94% at 230 Vac
- Power Boost of 150% for 5 seconds
- Advanced Power Boost (APB) of 200% for 50 ms
- SEMI F47 compliance at 120Vac
- Extreme low temperature cold start at -40°C
- Built-in DC OK Contact and LED indicator for DC OK
- Conformal coating on PCBAs to protect against common dust and chemical pollutants
- Certified according to IEC/EN/UL 62368-1

Safety Standards



CB Certified for worldwide use

Model Number: DRP-24V240W1C□N
Unit Weight: 0.84 kg (1.85 lb)
Dimensions (L x W x D): 124 x 60 x 117 mm
 (4.88 x 2.36 x 4.61 inch)

General Description

The CliQ III series of DIN rail power supply series is designed with high power density and intelligent overload protection features. All the models in the series are encased in rugged yet lightweight and full corrosion resistant aluminium casing. The single output with universal input design offers overcurrent protection in constant current mode which makes the series suitable for charging application. Like the rest of the CliQ family of products, conformal coating is applied on the PCBAs to protect against common dust and chemical pollutant often found in harsh industrial environment. Delta CliQ III DIN rail power supply series features built-in Power Boost of 150% for 5 seconds. Such feature enables reserve power to be always available for reliable startup of loads with high inrush current without the need of a more expensive power supply at higher power rating.

Model Information

CliQ III DIN Rail Power Supply

Model Number	Input Voltage Range	Rated Output Voltage	Rated Output Current
DRP-24V240W1C□N	88-264 Vac	24 Vdc	10.0 A

Model Numbering

DR	P –	24V	240W	1	C	□	N
DIN Rail	Power Supply	Output Voltage	Output Power	Single Phase	CliQ III	Input Voltage A – AC Input B – AC & DC Input	N – Metal Case, without Class I, Div 2 and ATEX approvals

(November 2021, Rev. 04)

Specifications

Input Ratings / Characteristics

Nominal Input Voltage	100-240 Vac	Applicable for TN-, TT and IT mains networks
Input Voltage Range	100-264 Vac	Continuously operating
	88-100 Vac	With power de-rating. Refer to Fig. 6 on page 11.
Input Frequency	Nom. 50-60 Hz	Range: 47-63 Hz
DC Input Voltage Range	100-375 Vdc	Continuously operating
	88-100 Vdc	With power de-rating. Refer to Fig. 7 on page 11.

		115 Vac	230 Vac	
Input Current	Typ.	2.27 A	1.19 A	At 24 V, 10 A. Refer to Fig. 1 on page 3.
	Max.	2.60 A	1.30 A	At 24 V, 10 A.
Efficiency	Typ.	92.70%	94.48%	At 24 V, 10 A. Refer to Fig. 2 on page 3.
	Min.	91.00%	93.00%	At 24 V, 10 A.
Average Efficiency	Typ.	91.52%	92.56%	At 24 V, 2.5 A (25%), 5.0 A (50%),
	Min.	91.00%	92.00%	7.5 A (75%), 10.0 A (100%)
Max Power Dissipation	Typ.	3.54 W	2.90 W	At 24 V, 0 A. Refer to Fig. 3 on page 3.
	Max.	6.0 W	6.0 W	At 24 V, 0 A.
	Typ.	18.97 W	14.05 W	At 24 V, 10 A. Refer to Fig. 3 on page 3.
	Max.	21.0 W	16.0 W	At 24 V, 10 A.
Max Inrush Current (Cold Start)	Typ.	11.0 A	24.4 A	At 24 V, 10 A.
	Max.	33 A	65 A	
Max Inrush Energy (Cold Start)	Max.	1 A ² s		
Power Factor	Typ.	0.99	0.93	At 24 V, 10 A. Refer to Fig. 4 on page 3.
	Min.	0.99	0.93	At 24 V, 10 A.
Leakage Current (Enclosure to Neutral)		< 0.25 mA / 0.80 mA < 0.38 mA / 1.00 mA < 0.74 mA / 2.00 mA		110 Vac, 50 Hz, TN/TT system / IT system 132 Vac, 50 Hz, TN/TT system / IT system 264 Vac, 50 Hz, TN/TT system / IT system

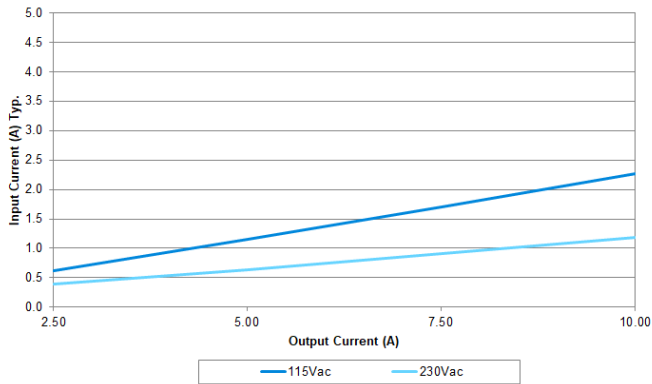

Fig. 1 Input Current VS Output Load at 24 V

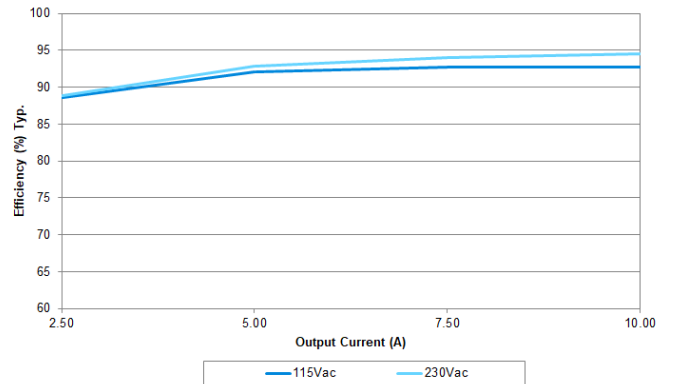

Fig. 2 Efficiency VS Output Load at 24 V

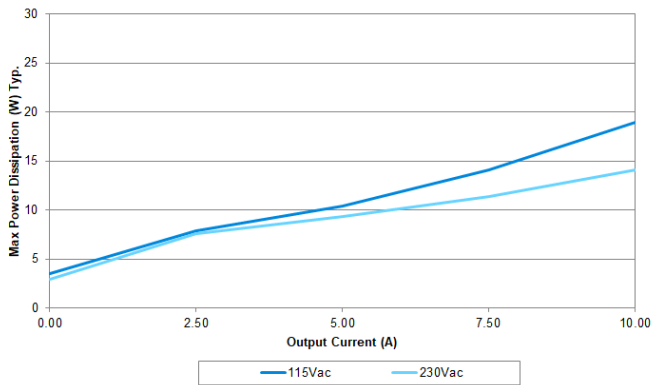

Fig. 3 Max Power Dissipation VS Output Load at 24 V

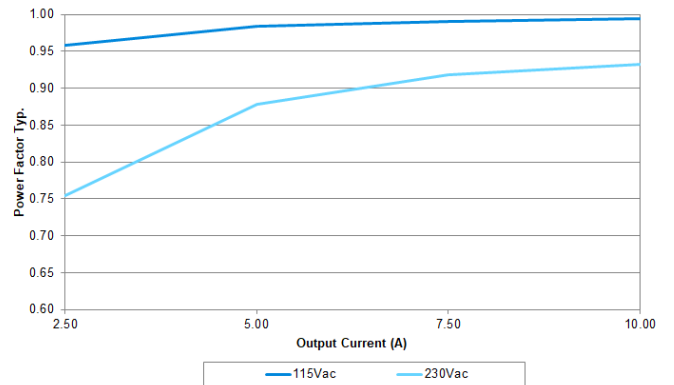

Fig. 4 Power Factor VS Output Load at 24 V

Output Ratings / Characteristics*

Nominal Output Voltage		24 Vdc	
Factory Set Point Tolerance		24 Vdc ± 1.0%	
Output Voltage Adjustment Range		24-28 Vdc	
Output Current	Nom. Nom.	0-10.0 A / 0-8.57 A 15.0 A / 12.86 A (Slew rate 0.1 A/μs)	Continuously operating at 24 V / 28 V Power Boost for 5 seconds at 24 V / 28V , refer to the details in the Function section
Output Power	Nom. Nom.	240 W / 240 W 360 W / 360 W	Continuously operating at 24 V / 28 V Power Boost for 5 seconds at 24 V / 28 V , refer to the details in the Functions section
Power Boost Duration	Min.	5 seconds	Duration after which output voltage start to droop. Refer to the details in the Function section at Overload & Overcurrent Protections
Power Boost Recovery Time	Typ.	18 seconds	Required wait duration before next Power Boost can be delivered by the power supply. Refer to the details in the Function section
Advanced Power Boost (Slew rate 0.1 A/μs)	Typ.	20 A @ 50 ms, resistive load	Output voltage will drop (Refer to the details in the Function section)
Line Regulation	Max.	0.5% (@ 88-264 Vac input, 100% load)	
Load Regulation	Max.	1.0% (@ 88-264 Vac input, 0-100% load)	
PARD**	Max.	100 mVpp	20 Hz to 20 MHz, 50 Ohm, warm up for 5 mins

*For power de-rating, see power de-rating on page 5.

**PARD is measured with an AC coupling mode, 5 cm wires, and in parallel with 0.1 μF ceramic capacitor & 47 μF electrolytic capacitor.

		115 Vac	230 Vac	
Rise Time	Max.	60 ms		At 24 V, 10 A.
Start-up Time	Max.	1,000 ms		At 24 V, 10 A.
Hold-up Time	Typ.	24 ms		At 24 V, 10 A.
	Min.	20 ms		At 24 V, 10 A.
Dynamic Response (Overshoot & Undershoot O/P Voltage)	Max.	± 5% @ 0-100% load		Slew rate 0.1 A/μs (@ 5 Hz, 50 Hz & 1 kHz, 50% Duty Cycle)
Start-up with Capacitive Loads	Max.	10,000 μF		
Functional	DC OK Relay Contact	Rated: 30 V at 1 A, resistive load. Refer to the details in the Function section at DC OK Relay Contacts and LED Indicator Characteristics on page 14.		

Mechanical

Case Cover / Chassis		Aluminium
Dimensions (L x W x D)		124 x 60 x 117 mm (4.88 x 2.36 x 4.61 inch)
Unit Weight		0.84 kg (1.85 lb)
Indicator	Green LED	DC OK
Cooling System		Convection
Terminal	Input	3 Pins (Rated 600 V / 35 A)
	Output	4 Pins (Rated 300 V / 28 A)
	Signal	2 Pins (Rated 300 V / 28 A)
Wire	Input	AWG 18-8
	Output	AWG 16-12
	Signal	AWG 16-12
Mounting Rail		Standard TS35 DIN Rail in accordance with EN 60715
Noise (1 Meter from power supply)		Sound Pressure Level (SPL) < 25 dBA

Environment

Surrounding Air Temperature	Operating	-25°C to +70°C (Cold start -40°C)
	Storage	-40°C to +85°C
Power De-rating	Vertical Mounting	> 60°C de-rate power by 2.5% / °C
	Horizontal Mounting	> 40°C de-rate power by 2.5% / °C
	Input Voltage	AC input < 100Vac de-rate power by 0.83% / V DC input < 100Vdc de-rate power by 1.67% / V
Operating Humidity		5 to 95% RH (Non-Condensing)
Operating Altitude		0 to 5,000 Meters (16,400 ft.)
Shock Test	Non-Operating	IEC 60068-2-27, Half Sine Wave: 30 G for a duration of 18 ms; 3 times per direction, 9 times in total
Vibration	Non-Operating	IEC 60068-2-6, Sine Wave: 10-500 Hz; 3 G peak; displacement of 0.35 mm; 60 min per axis for all X, Y, Z directions
Bump Test	Operating	IEC 60068-2-29, Half Sine Wave: 10 G for a duration of 11 ms, 1,000 times per direction, 6,000 times in total
Over Voltage Category		III (operating altitude 2,500 Meters) II (operating altitude 5,000 Meters) According to IEC/EN 62477-1 / EN 60204-1 (clearance and creepage distances) and IEC 62103 (safety part)
Pollution Degree		2

Protections

Overvoltage	28.8 - 35.2 V, SELV Output, Hiccup Mode, Non-Latching (Auto-Recovery)	Refer to the details in the Function section
Overload / Overcurrent	125 – 170% of rated load current, Constant current, Hiccup Mode (Auto-Recovery)	Refer to the details in the Function section
Over Temperature	< 80°C Surrounding Air Temperature @ 100% load, Non-Latching (Auto-Recovery)	Refer to the details in the Function section
Short Circuit	Hiccup Mode, Non-Latching (Auto-Recovery when the fault is removed)	Load impedance ≤ 100mOhm, refer to the details in the Function section
Transient Surge Voltage Protection	MOV (Metal Oxide Varistor)	
Internal Fuse at L pin	T 6.3 A	
Degree of Protection	IP20	
Protection Against Shock	Class I with PE* connection	

*PE: Primary Earth

Reliability Data

MTBF (as per Telcordia SR-332)	1,366,200 hrs.	I/P: 115 Vac, O/P: 24 V, 10 A, Ta: 25°C											
	767,400 hrs.	I/P: 115 Vac, O/P: 24 V, 10 A, Ta: 40°C											
Expected Cap Life Time**	<table border="1"> <thead> <tr> <th>115 Vac</th> <th>230 Vac</th> </tr> </thead> <tbody> <tr> <td colspan="2">87,600 hrs.</td> </tr> <tr> <td colspan="2">87,600 hrs.</td> </tr> <tr> <td>29,000 hrs.</td> <td>40,000 hrs.</td> </tr> <tr> <td>45,900 hrs.</td> <td>62,300 hrs.</td> </tr> </tbody> </table>		115 Vac	230 Vac	87,600 hrs.		87,600 hrs.		29,000 hrs.	40,000 hrs.	45,900 hrs.	62,300 hrs.	O/P: 24 V, 10 A, Ta: 25°C
	115 Vac	230 Vac											
	87,600 hrs.												
	87,600 hrs.												
	29,000 hrs.	40,000 hrs.											
45,900 hrs.	62,300 hrs.												
		O/P: 24 V, 5 A, Ta: 40°C											
		O/P: 24 V, 10 A, Ta: 60°C											
		O/P: 24 V, 7.5 A, Ta: 60°C											

**Estimated lifetime when 24 hours operating a day and E-cap's manufacturer guarantee at 87,600 hrs. (10 years) as maximum limit of lifetime.

Safety Standards / Directives

Electrical Equipment of Machines		EN/BS EN 60204-1 (over voltage category III)
Electrical Equipment for Use in Electrical Power Installations		IEC/EN/BS EN 62477-1 / IEC 62103
Safety Entry Low Voltage		SELV (IEC 60950-1)
Electrical Safety	SIQ Bauart	EN 62368-1
	UL/cUL recognized	UL 60950-1 and CSA C22.2 No. 60950-1 (File No. E191395) UL 62368-1 and CSA C22.2 No. 62368-1 (File No. E191395)
	CB scheme	IEC 60950-1, IEC 62368-1
	UKCA	BS EN 62368-1
Industrial Control Equipment	UL/cUL listed	UL 508 and CSA C22.2 No. 107.1-16 (File No. E315355)
CE		In conformance with EMC Directive 2014/30/EU and Low Voltage Directive 2014/35/EU
UKCA		In conformance with Electrical Equipment (Safety) Regulations 2016 No. 1011 and The Electromagnetic Compatibility Regulations 2016 No. 1091
Galvanic Isolation	4.0 kVac	Input / Output
	2.0 kVac	Input / PE
	4.0 kVac	Input / DC OK relay contact*
	1.5 kVac	Output / PE
	0.5 kVac	Output / DC OK relay contact
	1.5 kVac	DC OK relay contact / PE
PE Resistance		< 0.1 Ohm

*Recommend to connect DC OK pins together with output pins.

EMC

Emissions (CE & RE)	Generic Standards: EN/BS EN 61000-6-3 CISPR 32, EN/BS EN 55032, CISPR 11, EN/BS EN 55011, FCC Title 47: Class B		
Component Power Supply for General Use	EN/BS EN 61204-3		
Immunity	Generic Standards: EN/BS EN 55024, EN/BS EN 61000-6-2		
Electrostatic Discharge	IEC 61000-4-2	Level 4 Criteria A ¹⁾ Air Discharge: 15 kV Contact Discharge: 8 kV	
Radiated Field	IEC 61000-4-3	Level 3 Criteria A ¹⁾ 80 MHz – 1 GHz, 10 V/M, 80% modulation (1 kHz) 1.4 GHz – 2 GHz, 10 V/M, 80% modulation (1 kHz) 2 GHz – 2.7 GHz, 10 V/M, 80% modulation (1 kHz)	
Electrical Fast Transient / Burst	IEC 61000-4-4	Level 4 Criteria A ¹⁾ 4 kV	
Surge	IEC 61000-4-5	Level 4 Criteria A ¹⁾ Common Mode ³⁾ : 4 kV Differential Mode ⁴⁾ : 2 kV	
Conducted	IEC 61000-4-6	Level 3 Criteria A ¹⁾ 150 kHz – 80 MHz, 10 Vrms	
Power Frequency Magnetic Fields	IEC 61000-4-8	Criteria A ¹⁾ 30 A/Meter	
Voltage Dips and Interruptions	IEC 61000-4-11	0% of 100 Vac 40% of 100 Vac 70% of 100 Vac 0% of 100 Vac 0% of 240 Vac 40% of 240 Vac 70% of 240 Vac 0% of 240 Vac	0 Vac, 20 ms 40 Vac, 200 ms 70 Vac, 500 ms 0 Vac, 5000 ms 0 Vac, 20 ms 40V ac, 200 ms 70 Vac, 500 ms 0 Vac, 5000 ms
Low Energy Pulse Test (Ring Wave)	IEC 61000-4-12	Level 3 Criteria A ¹⁾ Common Mode ³⁾ : 2 kV Differential Mode ⁴⁾ : 1 kV	
Harmonic Current Emission	IEC/EN/BS EN 61000-3-2, Class A		
Voltage Fluctuation and Flicker	IEC/EN/BS EN 61000-3-3		
Voltage Sag Immunity SEMI F47 – 0706	80% of 120 Vac 70% of 120 Vac 50% of 120 Vac 80% of 200 Vac 70% of 200 Vac 50% of 200 Vac	96 Vac, 1000 ms 84 Vac, 500 ms 60 Vac, 200 ms 160 Vac, 1000 ms 140 Vac, 500 ms 100V ac, 200 ms	Criteria A ¹⁾ Criteria A ¹⁾ Criteria A ¹⁾ Criteria A ¹⁾ Criteria A ¹⁾ Criteria A ¹⁾
VDE 0160	Over entire load range	750 V, 1.3 ms	Criteria A ¹⁾

1) Criteria A: Normal performance within the specification limits
2) Criteria B: Temporary degradation or loss of function which is self-recoverable
3) Asymmetrical: Common mode (Line to earth)
4) Symmetrical: Differential mode (Line to line)

Block Diagram

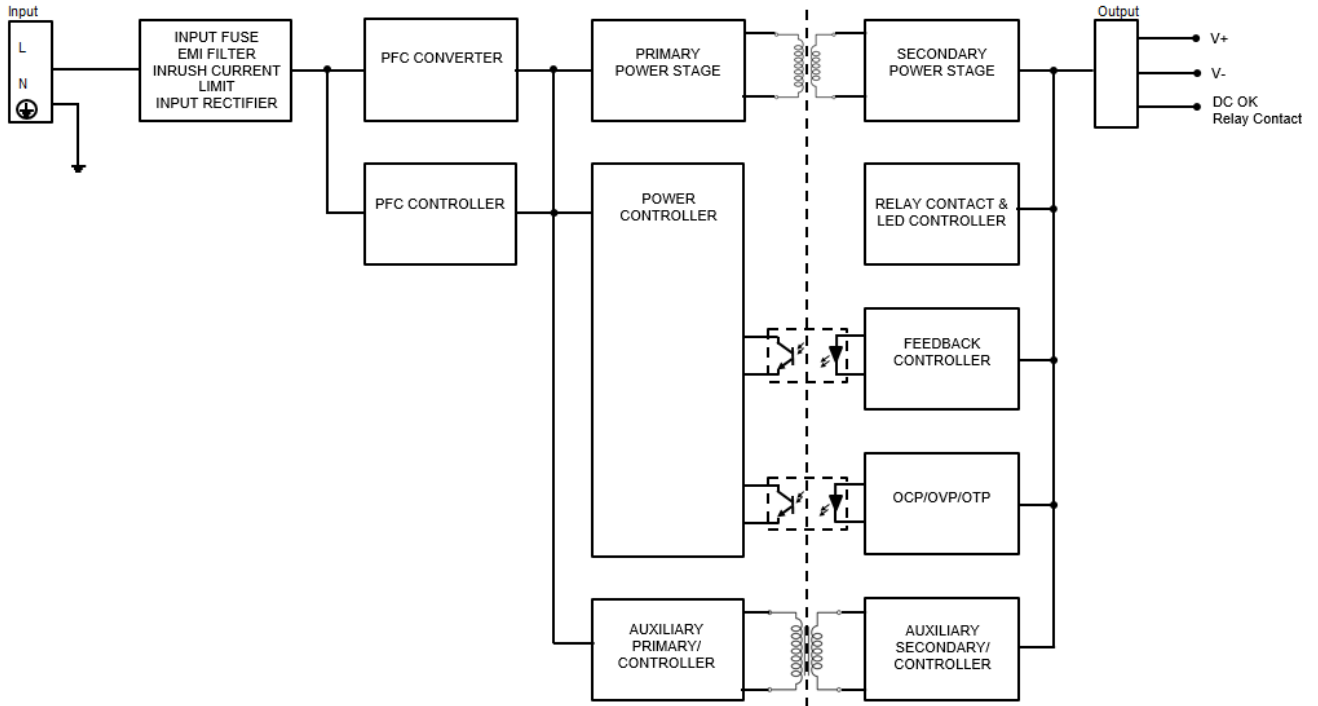

Device Description

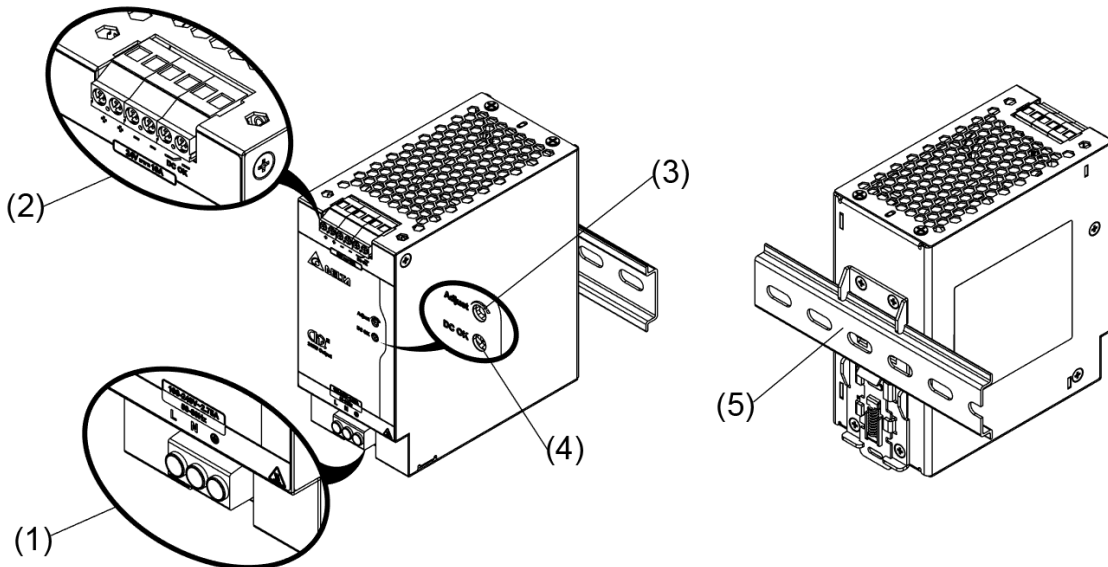

- 1) Input terminal block connector
- 2) Output / Signal terminal block connector
- 3) DC voltage adjustment potentiometer
- 4) DC OK LED (Green)
- 5) Universal mounting rail system

Dimensions

L x W x D: 124 x 60 x 117 mm (4.88 x 2.36 x 4.61 inch)

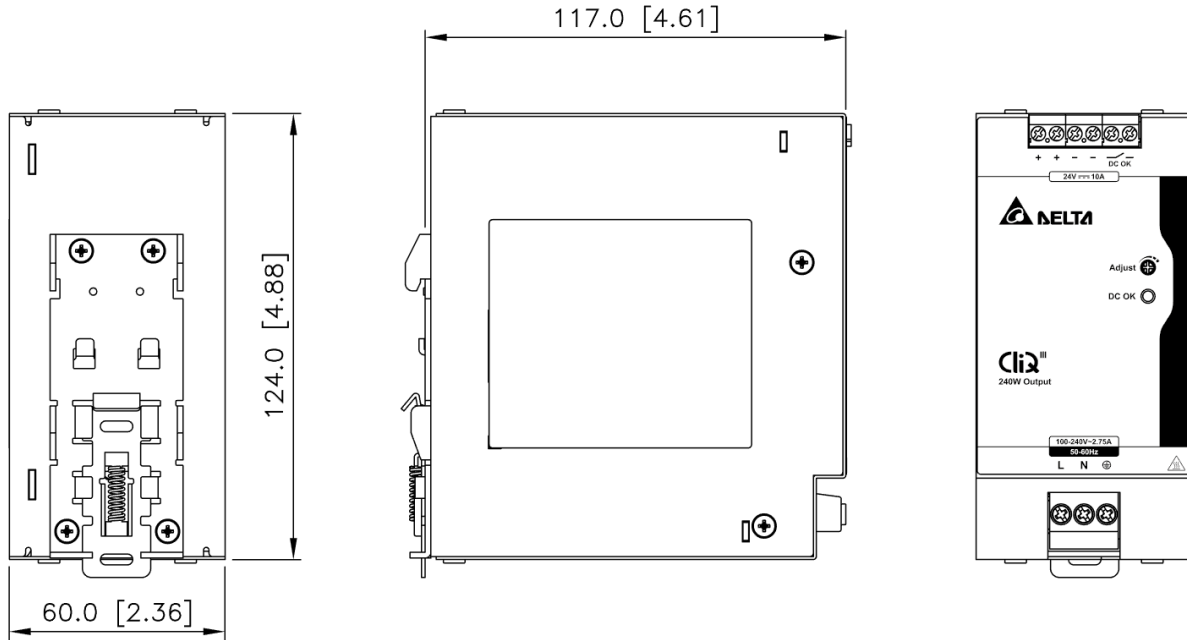

Engineering Data

Output Load De-rating VS Surrounding Air Temperature

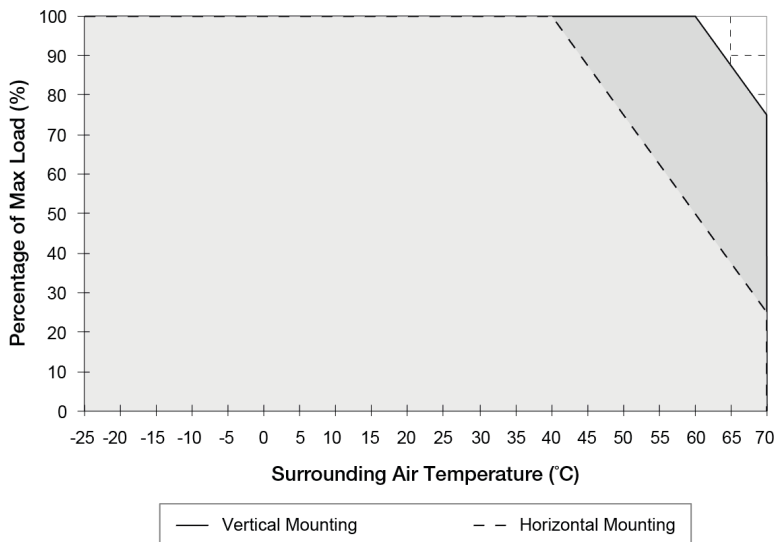

Fig. 5 De-rating for Vertical Mounting Orientation
 > 60°C de-rate power by 2.5% / °C

De-rating for Horizontal Mounting Orientation
 > 40°C de-rate power by 2.5% / °C

Note

1. Power supply components may degrade, or be damaged, when the power supply is continuously used outside the shaded region, refer to the graph shown in Fig. 5.
2. If the output capacity is not reduced when the surrounding air temperature exceeds its specification as defined on Page 5 under "Environment", the device will run into Over Temperature Protection. When activated, the output voltage will go into bouncing mode and will recover when the surrounding air temperature is lowered or the load is reduced as far as necessary to keep the device in working condition.
3. In order for the device to function in the manner intended, it is also necessary to keep a safety distance as recommended in the safety instructions while the device is in operation.
4. Depending on the surrounding air temperature and output load delivered by the power supply, the device can be very hot!
5. If the device has to be mounted in any other orientation, please contact info@deltapsu.com for more details.

Output Load De-rating VS Input Voltage

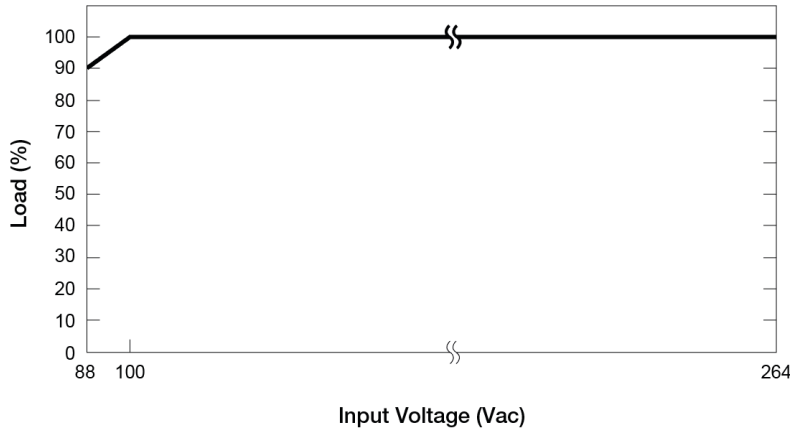

- Output power de-rating for the AC input voltage range, refer to Fig. 6.

Fig. 6 De-rating for AC input voltage
 < 100 Vac de-rate power by 0.83% / V

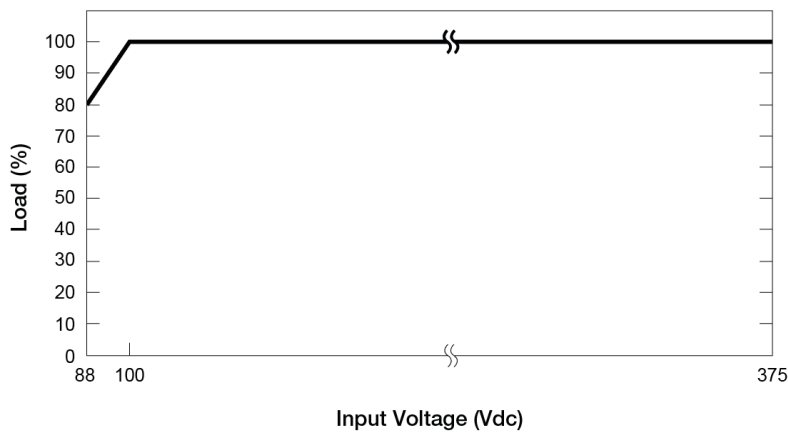

- Output power de-rating for the DC input voltage range, refer to Fig. 7.

Fig. 7 De-rating for DC input voltage
 < 100 Vdc de-rate power by 1.67% / V

Assembly & Installation

The power supply unit (PSU) can be mounted on 35 mm DIN rails in accordance with EN 60715. For Vertical Mounting, the device should be installed with input terminal block at the bottom. For Horizontal Mounting, the device should be installed with input terminal block on the left side.

Each device is delivered ready to install.

1. Tilt the unit upwards and insert it onto the DIN rail. Snap on the DIN rail as shown in Fig. 8.1.
2. Push downwards until stopped.
3. Press against the bottom front side for locking.
4. Shake the unit slightly to ensure that it is secured.
5. To uninstall, pull or slide down the latch with screw driver as shown in Fig. 8.2. Then slide the power supply unit (PSU) in the opposite direction, release the latch and pull out the power supply unit (PSU) from the rail.

Mounting

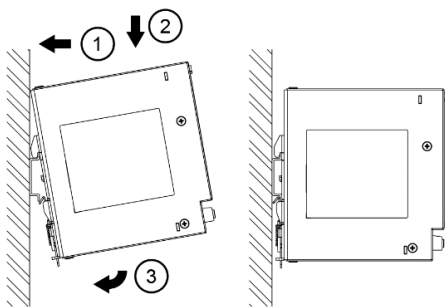

Fig. 8.1 Mounting

Dismounting

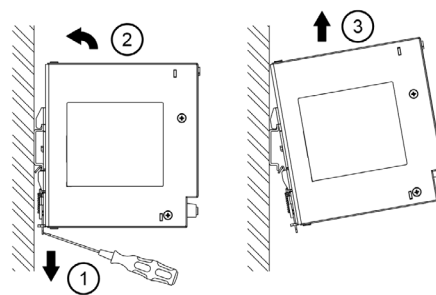

Fig. 8.2 Dismounting

In accordance to EN 60950 / UL 60950 and EN 62368 / UL 62368, flexible cables require ferrules. Use appropriate copper cables designed to sustain operating temperature of:

1. 60°C / 75°C for USA
2. At least 75°C for ambient up to 40°C (Canada)
3. At least 90°C for ambient > 40°C (Canada)

Safety Instructions

■ Vertical Mounting

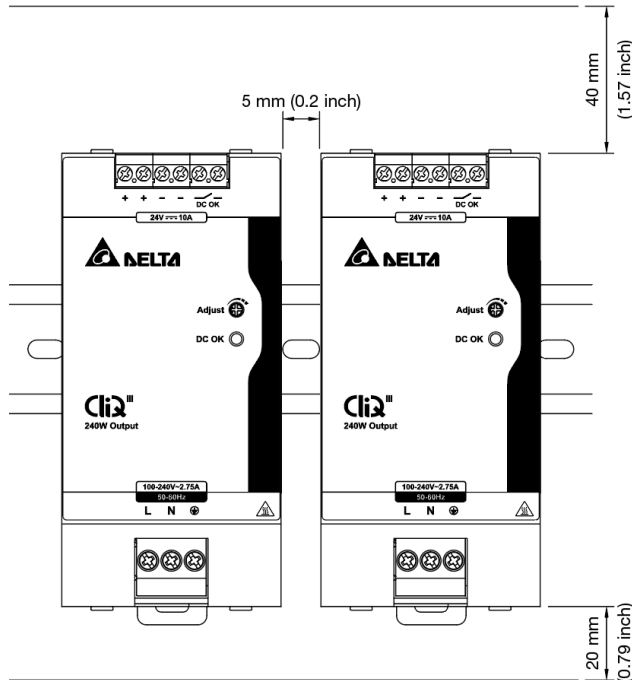

■ Horizontal Mounting

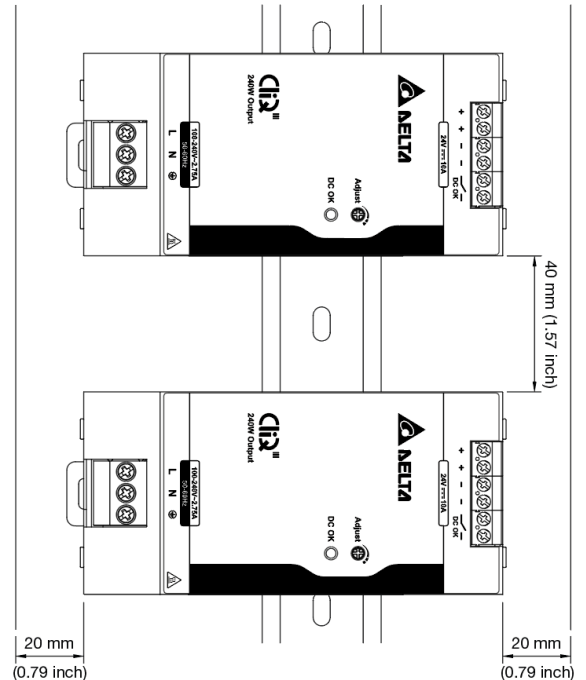

- ALWAYS switch mains of input power OFF before connecting and disconnecting the input voltage to the device. If mains are not turned OFF, there is risk of explosion / severe damage.
- If the unit is used in a manner not specified by the manufacturer, the protection provided by the equipment may be impaired.
- **To guarantee sufficient convection cooling, please refer to the following instructions to ensure sufficient clearance around the device.**
Vertical Mounting: 40 mm (1.57 inch) above and 20 mm (0.79 inch) below the device as well as a lateral distance of 5 mm (0.2 inch) to other units. In case the adjacent device is a heat source, the lateral distance will be 15 mm (0.6 inch).
Horizontal Mounting: 40 mm (1.57 inch) above and below the device as well as a lateral distance of 20 mm (0.79 inch) to other units.
- The external enclosure where the unit will be installed shall meet the requirements for mechanical, electrical and fire enclosure.
- Note that the enclosure of the device can become very hot depending on the surrounding air temperature and output load connected to the device. Risk of burns!
- The main power must be turned off before connecting or disconnecting wires to the terminals.
- DO NOT insert any objects into the unit.
- Dangerous voltages present for at least 5 minutes after disconnected all sources of power.
- The power supplies are built in units and must be installed in a cabinet or room (condensation free environment and indoor location) that is relatively free of conductive contaminants.

Functions

DC OK Relay Contacts and LED Indicator Characteristics

DC OK Relay Contacts Status	Characteristics
Contact closes	The output voltage reaches 90% of its steady state set value.
Contact opens	The output voltage dip lower than 90% of its steady state set value.

Operating Status	DC OK (Green LED)	DC OK Relay Contact
Normal Operation	ON	Closed
During Power Boost	ON	Closed
Overload ($V_{out} \leq 90\%$ of adjusted voltage)	OFF	Open
Output Short Circuit	OFF	Open
Over Temperature	OFF	Open
No Input Power	OFF	Open

■ Graph illustrating the Start-up Time, Rise Time, and Hold-up Time

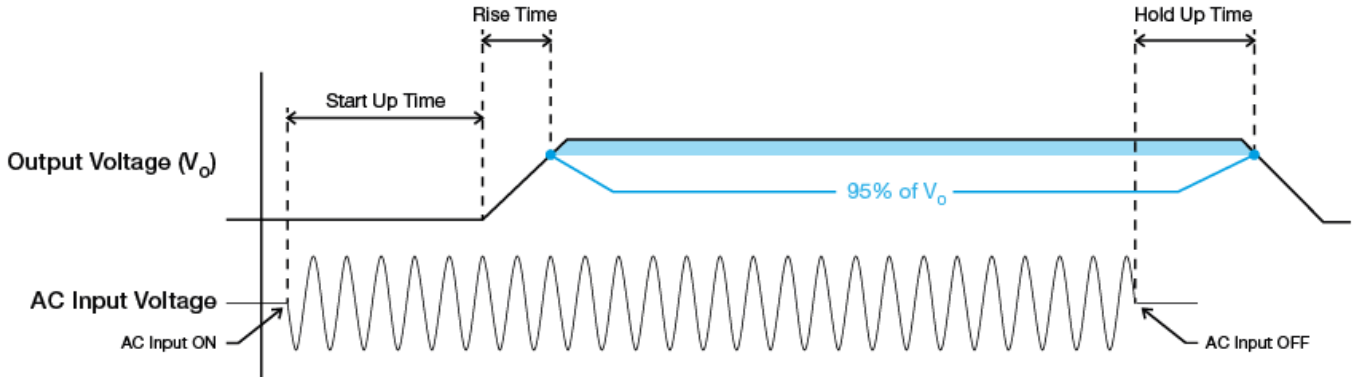

Start-up Time

The time required for the output voltage before output voltage rise up, after the input voltage is applied.

Rise Time

The time required for the output voltage to change from 0% to 95% of its final steady state set value.

Hold-up Time

Time between the collapse of the AC input voltage, and the output falling to 95% of its steady state set value.

Inrush Current

Inrush current is the peak, instantaneous, input current measured and, occurs when the input voltage is first applied. For AC input voltages, the maximum peak value of inrush current will occur during the first half cycle of the applied AC voltage. This peak value decreases exponentially during subsequent cycles of AC voltage.

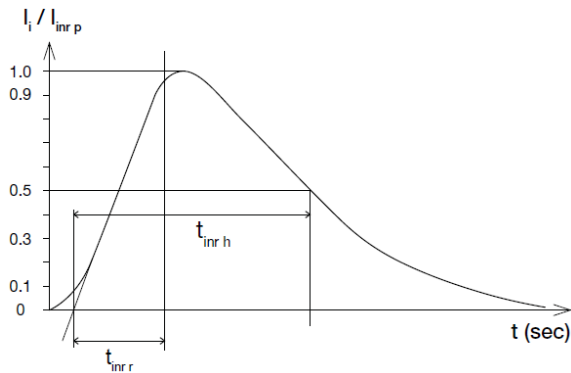

Dynamic Response

The power supply output voltage will remain within $\pm 5\%$ of its steady state value, when subjected to a dynamic load from 0% to 100% of its rated current.

- 50% duty cycle / 5 Hz to 1 kHz

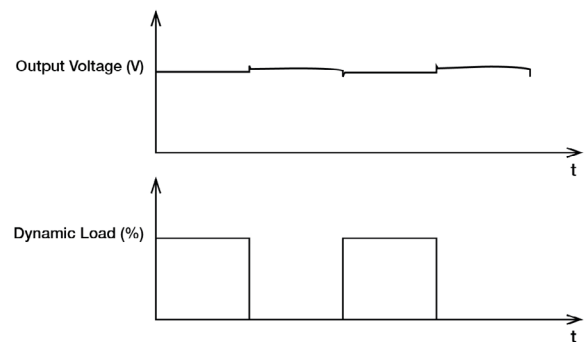

Overload & Overcurrent Protections (Auto-Recovery)

The power supply's Overload (OLP) and Overcurrent (OCP) Protections will be activated when output current (I_O) is about 125 - 170%. In such occurrence, output voltage (V_O) will start to droop and the I_O will limit to 18 A typ. (refer to ③). After 5 sec typ., the I_O will limit to 11 A typ. (refer to ①). Once V_O is below approximately 10 Vdc typ., the power supply will start to operate in "Hiccup mode" (refer to ②). The power supply will recover once the fault condition due to OLP or OCP is removed, then I_O is back within its specified limits.

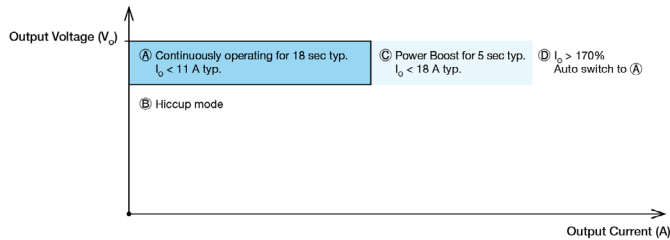

It is not recommended to prolong the duration of output current when it is <125% but >100%, since it may cause damage to the PSU.

Short Circuit Protection (Auto-Recovery)

The power supply's output Short Circuit Protection function also provides protection against short circuits. When a short circuit is applied, the output current will start to operate in "Hiccup mode". The power supply will return to normal operation after the short circuit is removed.

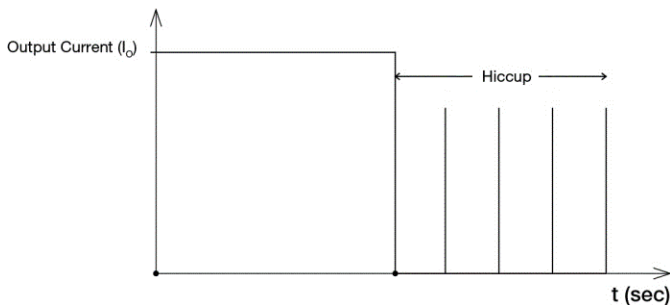

Overvoltage Protection (Auto-Recovery)

The power supply's overvoltage circuit will be activated when its internal feedback circuit fails. The output voltage shall not exceed its specifications defined on Page 6 under "Protections".

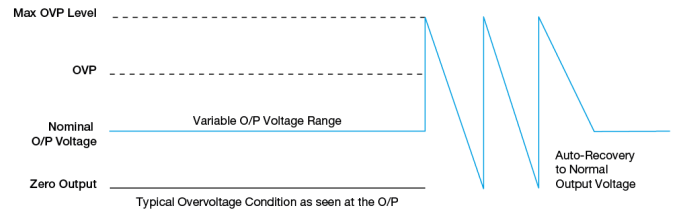

Over Temperature Protection (Auto-Recovery)

As described in load de-rating section, the power supply also has Over Temperature Protection (OTP). In the event of a higher operating temperature at 100% load, the power supply will run into OTP when the operating temperature is beyond what is recommended in the de-rating graph. When activated, the output voltage will go into bouncing mode until the temperature drops to its normal operating temperature as recommended in the de-rating graph.

Power Boost

Power Boost is the reserve power available constantly that allows reliable startup to support sudden and short spike of loads with high inrush current typically during turn on to remove the need of more expensive higher rated power supply unit. After the output has reached its steady state set value, the power supply can support surge loads with a higher short-term power demand up to 150% of maximum rated load (I_O Max), for a typical duration of 5 seconds. If the power boost lasts longer than typical duration, the output current will limit to 11 A typ. and output voltage will start to droop, refer to the details in overload & overcurrent protections and the next Power Boost will be available after power boost recovery time defined on Page 4. In order to avoid this, need to maintain the duty cycle & recovery time to ensure that average (R.M.S) output power shall not exceed the continuous maximum, see duty cycle calculation below.

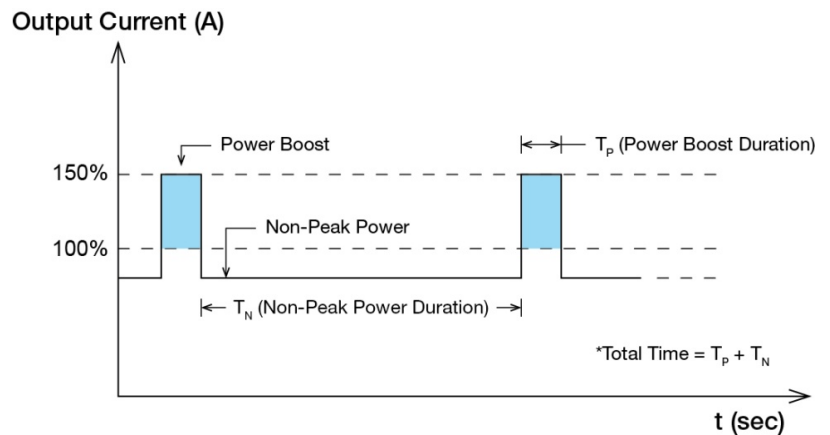

Fig. 9 Duty Cycle Calculation

$$\text{Duty cycle (\%)} = \frac{T_P}{\text{Total Time}}$$

$$\text{Average Output Power (} P_{Avg} \text{)} = \frac{(\text{Power Boost} \times T_P) + (\text{Non-Peak Power} \times T_N)}{\text{Total Time}}$$

OR

$$\text{Non-Peak Power} = \frac{(P_{Avg} \times \text{Total Time}) - (\text{Power Boost} \times T_P)}{T_N}$$

■ An example of Power Boost and Average Output Power

Power Boost	Peak Power (W_P)	Power Boost Duration (T_P)	Duty Cycle	Non-Peak Power (W_N)	Non-Peak Power Duration (T_N)	Total Time (T)
150%	180	1 sec	10%	227 W	9 sec	10 sec
150%	180	5 sec	30%	188 W	11.5 sec	16.5 sec
125%	150	1 sec	10%	233 W	9 sec	10 sec
125%	150	5 sec	30%	214 W	11.5 sec	16.5 sec

Advanced Power Boost (APB)

With multiple loads connected in a system and due to one of fault load a large inrush current is drawn (demanded), this will be detected by APB. This product has a feature of APB up to 200% load for 50 ms.

The following waveforms demonstrate the typical output voltage and output current when APB is activated.

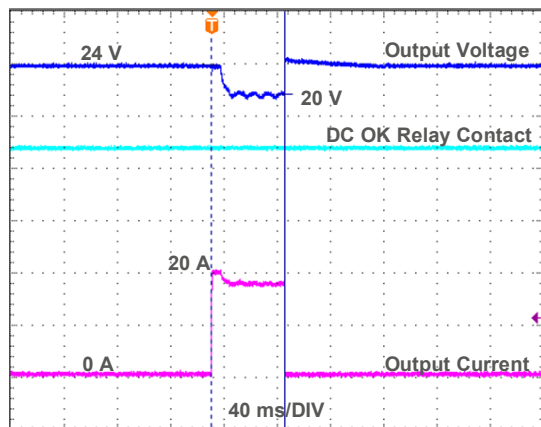

Fig. 10 APB 200% of nominal output current for 50 ms

External Input Protection Device

The unit is protected at the L pin, with an internal fuse that cannot be replaced. The power supply has been tested and approved on 20 A (UL) and 16 A (IEC) branch circuits without additional protection device. An external protection device is only required if the supplying branch has an ampacity greater than above. Thus, if an external protective device is necessary, or, utilized, please refer a minimum value in instruction sheet with 6 A B- or 4 A C- characteristic breaker.

Operating Mode

■ Redundant Operation

In order to ensure proper redundant operation for the power supply units (PSUs), the output voltage difference between the two units must be kept at 0.45~0.50 V for these 24 V supplies. Follow simple steps given below to set them up for the redundant operation:

Step 1.

Measure output voltage of PSU 1 and PSU 2. If PSU 1 is the master unit, then V_O of PSU 1 must be higher than PSU 2. In order to set the output voltage, individually connect each power supply to 50% of rated load at any line voltage, and set the PSU 1 and PSU 2 output voltage.

Step 2.

Connect the power supply units PSU 1 and PSU 2 to Vin 1 & Vin 2, respectively, of the DRR-20N (or 20A) module shown on the right of above diagram.

Step 3.

Connect the system load to V_{out} . Please note that output voltage V_{out} from DRR module will be $= V_O$ (output voltage of power supply) $- V_{drop}^*$ (in DRR module).

* V_{drop} will vary from 0.60 V to 0.90 V (Typical 0.65 V) depending on the load current and surrounding air temperature.

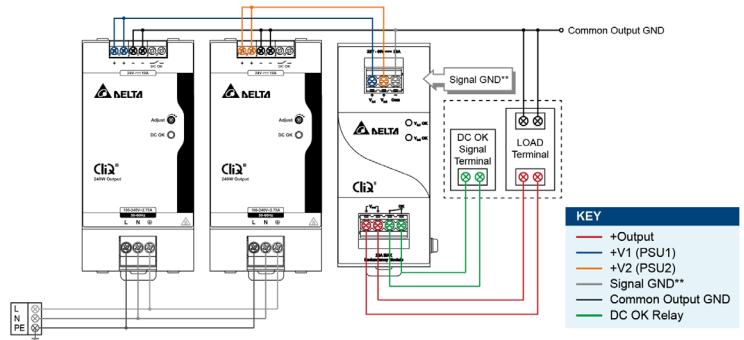

**The Signal GND in the DRR module is for the built-in LED and DC OK signals. The Output GND terminals from the two PSU's do not need to be connected to the Signal GND terminal.

Fig. 11 Redundant Operation Connection Diagram

■ Parallel Operation

The power supply units (PSUs) can also be used for parallel operation in order to increase the output power. The difference in output voltage between the two units must be kept to within 25 mV of each other. This difference must be verified with the same output load connected independently to each unit.

Parameters such as EMI, inrush current, leakage current, PARD, start up time will be different from those on the datasheet, when two units are connected in parallel. The user will need to verify that any differences will still allow the two power supplies connected in parallel will work properly in their product/application.

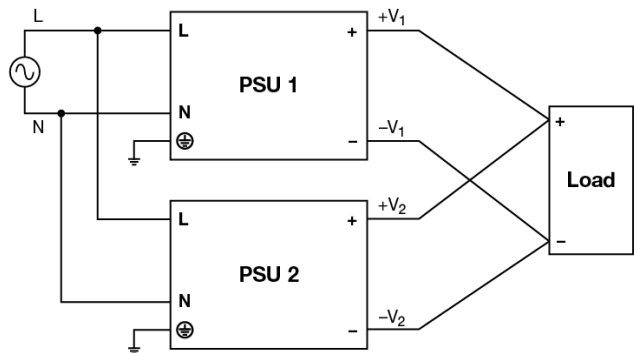

Fig. 12 Parallel Operation Connection Diagram

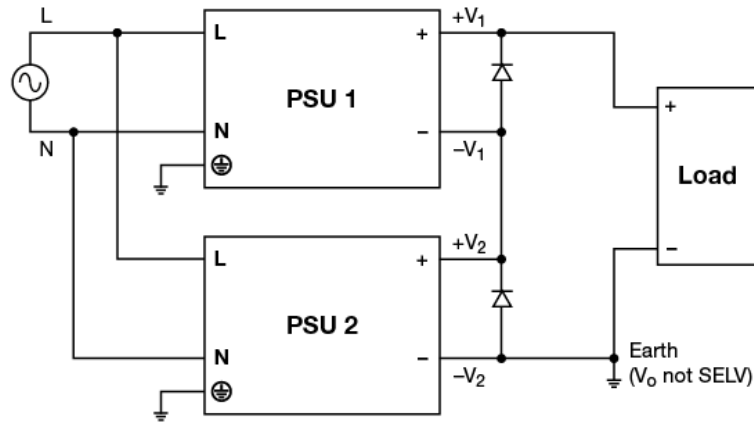
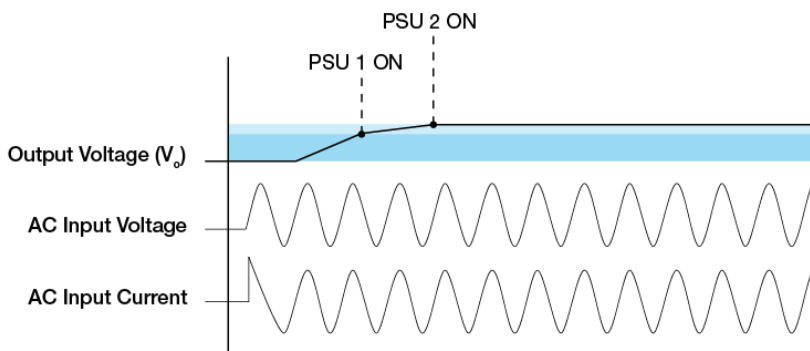

Fig. 13 Series Operation Connection Diagram

■ Series Operation

Delta's CliQ III can be connected in series to increase the output voltage as shown in figure above. Only power supply from the same product series, and with the same rated output current, can be used. The maximum load current should not exceed the smallest rated output current. Any number of power supplies can be connected in series. User must note that an output voltage > 60 Vdc will not meet SELV requirements and could be dangerous to user, the total voltage shall not exceed 150 Vdc. Installation a protection against the touching is a must and connect the output ground to earth when output voltage is not SELV. A diode in reverse bias must be added across output terminals of each power supply, this is to prevent -V voltage being applied to other power supply in fault conditions such as short circuit across load. During the short circuit -V₁ & +V₁ will come across +V₂ & -V₂ which means connecting 2 power supplies in opposite polarity and may cause damage to power supply. With reverse bias diodes in place the voltage across each power supply will be restricted to one diode drop – approximately 0.7 V to 1.0 V. It is recommended to provide sufficient voltage de-rating for diodes with 2 times the voltage rating of series output voltage. E.g. the two 24 V power supplies are connected in series, the total voltage is 48 volts. Hence, recommended to use diodes with reverse voltage rating of 2x48=96 volts. Therefore, diodes with reverse voltage rating of 100 volts can be used.

During the short circuit condition, the current through diodes will be large, hence it is recommended that diodes to be least twice the current rating of the power supply.



The turn ON would be non-monotonic as the power supply with the fastest startup time and rise time will turn on first. As a result, the combined output voltage waveform of the 2 power supplies connected in series will include a step.

User must consider to verify parameters such as EMI, inrush current, leakage current, PARD, start up time would differ from datasheet numbers as multiple power supplies in series.

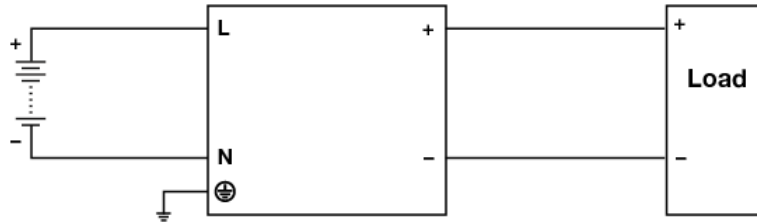

Fig. 14 DC Input Operation Connection Diagram

■ DC Input Operation

Step 1.

Use a battery or similar DC source.

Step 2.

Connect +pole to L and -pole to N.

Step 3.

Connect the PE terminal to an earth wire or to the machine ground.

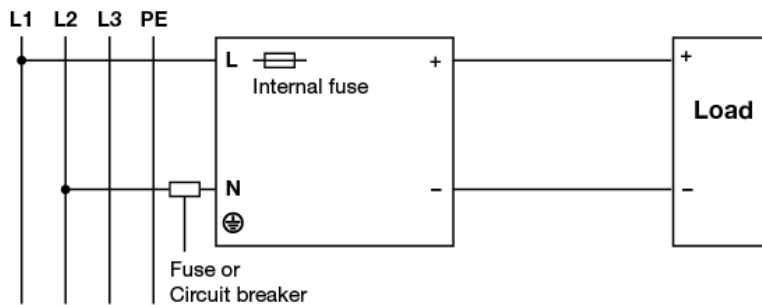

Fig. 15 2 of 3 Phase System Input Operation Connection Diagram

■ 2 of 3 Phase System Input Operation

Delta's CliQ III can use on 2 of 3 phase system. Please refer to the following step.

Step 1.

The input voltage applied from Line to Neutral is below the maximum rated input. The input voltage shall be below 240 Vac +10%.

Step 2.

The external protector is needed on N (Neutral) input line to secure a safety. N line does not have internal fuse protection. An appropriate fuse or circuit breaker should be connected in series with N input line connection like the following.

Others

Conformal Coating

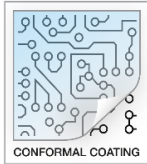

The Protective Coating Technology

Delta Electronics Group has designed the perfect dipping technique which penetrates everywhere including under device, and prevents leakage. The conformal coating dipping can be applied to PCBAs or circuit board. The coating preserves the performance of precision electronic primarily by preventing ionizable contaminants such as salt from reaching circuit nodes, where the material slumps around sharp edges. This can be a problem especially in highly conversing atmosphere.

PFC – Norm EN 61000-3-2

Line Current Harmonic content

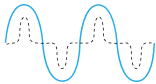

Typically, the input current waveform is not sinusoidal due to the periodic peak charging of the input capacitor. In industrial environments, compliance with EN 61000-3-2 is only necessary under special conditions. Complying to this standard can have some technical drawbacks, such as lower efficiency; and, can also result in higher product cost. Frequently, the user does not profit from compliance to this standard; therefore, it is important to know whether it is mandatory to meet this standard for a specific application.

(November 2021, Rev. 04)