



Highlights & Features

- Built-in constant current circuit for charging application
- Full power from -25°C to +60°C @ 5,000 m (16,400 ft.)
- Power Boost of 150% up to 7 seconds
- Advanced Power Boost (APB) – protect system and ensure continuing operation when large inrush current detected due to faulty load on a multiple load connection
- DNV GL and ABS approvals for maritime applications
- Built-in DC OK Contact and LED indicator for DC OK/ Overload
- Conformal coating on PCBAs to protect against common dust and chemical pollutants

Safety Standards



CB Certified for worldwide use

Model Number: DRM-24V480W3PN
Unit Weight: 1.18 kg (2.60 lb)
Dimensions (L x W x D): 124.0 x 65.0 x 127.1 mm
 (4.88 x 2.56 x 5.00 inch)

General Description

Delta Electronics is introducing one of the slimmest DIN rail industrial power supplies in its class, the CliQ M DIN rail power supply series. To fulfill the demands in maritime applications, the product is designed according to major industrial and maritime (Lloyd's Register) safety standards. Other features include compliance with harmonic current IEC/EN 61000-3-2, class A, built-in DC OK contacts, and an LED for indicating DC OK and Overload conditions. In addition to having Power Boost of 150% up to 7 seconds, the CliQ M series is the first in the CliQ family to feature Advanced Power Boost (APB). With multiple loads connected in a system, a large inrush current could be drawn (demanded) due to one fault load. This will be detected by APB. The APB will trip the circuit breaker (circuit breaker with appropriate rating based on the system load) on the current path of the fault load due to high current. This thus prevents the system from shutting down while the other connected current paths continue to operate without interruption.

Model Information

CliQ M DIN Rail Power Supply

Model Number	Input Voltage Range	Rated Output Voltage	Rated Output Current
DRM-24V480W3PN	3 x 320-575 Vac (3-Phase) or 2 x 380-575 Vac (2-Phase)	24 Vdc	20.0 A

Model Numbering

DR	M –	24V	480W	3	P	N
DIN Rail	CliQ M Series	Output Voltage	Output Power	Three Phase	Advanced Power Boost (APB)	N - Metal Case, without Class I, Div 2 and ATEX approvals

(October 2021, Rev. 01)

Specifications

Input Ratings / Characteristics

Nominal Input Voltage	3 x 400-500 Vac	Applicable for TN-, TT and IT mains networks
Input Voltage Range	3 x 320-575 Vac (3-Phase) or 2 x 380-575 Vac (2-Phase)	Continuously operating
Input Frequency	Nom. 50-60 Hz	Range: 47-63 Hz
DC Input Voltage Range	450-800 Vdc	Fulfills the test conditions for DC input. DC input safety approval can be obtained upon request.

		400 Vac	480 Vac	500 Vac	
Input Current	Typ.	0.78 A	0.67 A	0.66 A	At 24 V, 20 A. Refer to Fig. 1 on page 3.
	Max.	0.79 A	0.68 A	0.68 A	At 24 V, 20 A.
Efficiency	Typ.	95.23%	95.24%	95.24%	At 24 V, 20 A. Refer to Fig. 2 on page 3.
	Min.	95.00%	94.80%	94.80%	At 24 V, 20 A.
Average Efficiency	Typ.	93.42%	93.21%	93.14%	At 24 V, 5.0 A (25%), 10.0 A (50%), 15.0 A (75%), 20.0 A (100%)
Max Power Dissipation	Typ.	4.60 W	5.00 W	5.10 W	At 24 V, 0 A. Refer to Fig. 3 on page 3.
	Max.	8.20 W	10.00 W	10.00 W	At 24 V, 0 A.
	Typ.	16.19 W	16.67 W	16.80 W	At 24 V, 10 A. Refer to Fig. 3 on page 3.
	Max.	17.50 W	18.00 W	18.00 W	At 24 V, 10 A.
	Typ.	24.08 W	24.03 W	24.01 W	At 24 V, 20 A. Refer to Fig. 3 on page 3.
	Max.	25.30 W	26.40 W	26.40 W	At 24 V, 20 A.
Max Inrush Current (Cold Start)	Typ.	7.4 A	8.3 A	8.6 A	Entire operating temperature range
	Max.	10.0 A	10.0 A	10.0 A	
Max Inrush Energy (Cold Start)	Max.	1.0 A ² s			
Power Factor	Typ.	0.93	0.90	0.89	At 24 V, 20 A. Refer to Fig. 4 on page 3.
	Min.	0.93	0.90	0.88	At 24 V, 20 A.
Leakage Current (Enclosure to Neutral)		< 0.80 mA / 0.80 mA < 1.00 mA / 1.00 mA < 1.20 mA / 1.20 mA < 1.30 mA / 1.30 mA			3x400 Vac, 50 Hz, TN/TT / IT system 3x440 Vac, 50 Hz, TN/TT / IT system 3x480 Vac, 60 Hz, TN/TT / IT system 3x528 Vac, 60 Hz, TN/TT / IT system

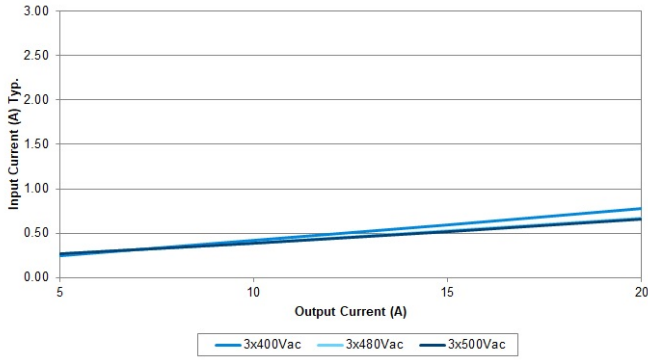

Fig. 1 Input Current VS Output Load at 24 V

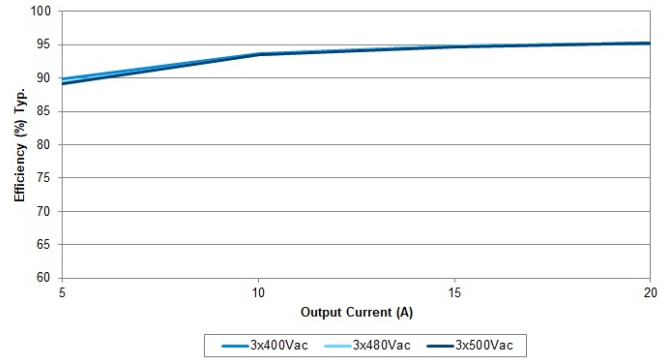

Fig. 2 Efficiency VS Output Load at 24 V

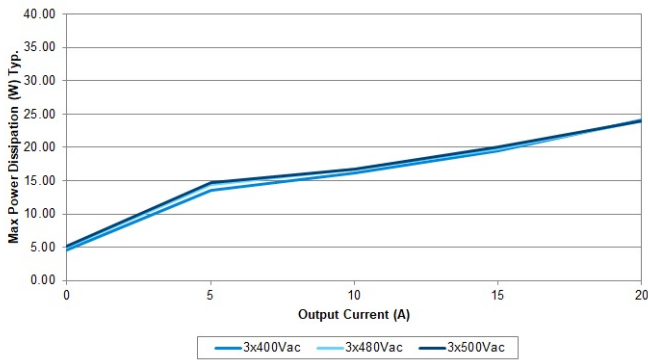

Fig. 3 Max Power Dissipation VS Output Load at 24 V

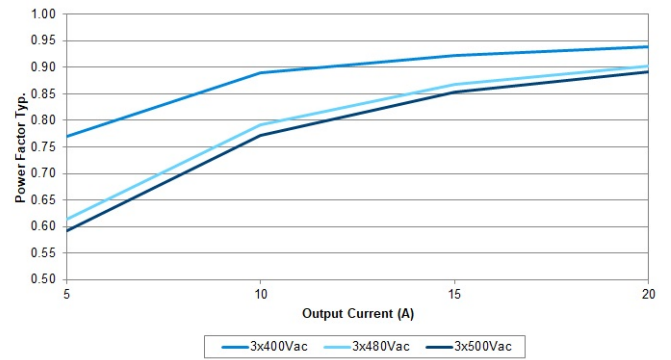

Fig. 4 Power Factor VS Output Load at 24 V

Output Ratings / Characteristics*

Nominal Output Voltage		24 Vdc	
Factory Set Point Tolerance		24 Vdc ± 1.0%	
Output Voltage Adjustment Range		24-28 Vdc	
Output Current	Nom. Nom.	20.0 A / 17.1 A 30.0 A / 25.65 A (Slew rate 0.1 A/μs)	Continuously operating at 24 V / 28 V Power Boost for 5 seconds at 24 V / 28 V, refer to the details in the Function section
Output Power	Nom. Nom.	480 W / 478.8 W 720 W / 718.2 W	Continuously operating at 24 V / 28 V Power Boost for 5 seconds at 24 V / 28 V, refer to the details in the Functions section
Power Boost Duration	Typ. Max.	4 seconds 7 seconds	Duration after which output voltage start to droop. Refer to the details in the Function section at Overload & Overcurrent Protections
Power Boost Recovery Time	Typ.	17 seconds	Required wait duration before next Power Boost can be delivered by the power supply. Refer to the details in the Function section
Advanced Power Boost (Slew rate 0.1 A/μs)	Typ. Typ. Typ.	40 A @ 50 ms, resistive load 80 A @ 2 ms, resistive load 80 A @ 5 ms, resistive load	Output voltage will drop (Refer to the details in the Function section)
Line Regulation	Max.	10 mV (@ 3 x 320-575 Vac input, 100% load)	
Load Regulation	Max.	100 mV (@ 3 x 320-575 Vac input, 0-100% load)	
PARD**	Max.	100 mVpp	20 Hz to 20 MHz, 50 Ohm, warm up for 5 mins

*For power de-rating from 60°C to 70°C, see power de-rating on page 5.

**PARD is measured with an AC coupling mode, 5 cm wires, and in parallel with 0.1 μF ceramic capacitor & 10 μF electrolytic capacitor.

		400 Vac	480Vac	500Vac	
Rise Time	Max.		30 ms		0 μF, 24 V, 20 A.
	Max.		40 ms		20,000 μF, 24 V, 20 A.
Start-up Time	Max.		500 ms		At 24 V, 20 A.
Hold-up Time	Typ.		44 ms		At 24 V, 10 A.
	Min.		36 ms		At 24 V, 10 A.
	Typ.		22 ms		At 24 V, 20 A.
	Min.		18 ms		At 24 V, 20 A.
Dynamic Response (Overshoot & Undershoot O/P Voltage)	Max.		± 5% @ 1.5-100% load		Slew rate 0.1 A/μs (@ 5 Hz, 50 Hz, 100 Hz & 1 kHz, 50% Duty Cycle)
Start-up with Capacitive Loads	Max.		20,000 μF		
Output Capacitance	Typ.		6,600 μF		Built-in output capacitors
Functional	DC OK Relay Contact		Rated: 30 V at 1 A, resistive load. Refer to the details in the Function section at DC OK Relay Contacts and LED Indicator Characteristics on page 13.		
	Parallel operation		Yes, refer to Parallel Operation on page 18.		

Mechanical

Case Cover / Chassis		Aluminium
Dimensions (L x W x D)		124 x 65 x 127.1 mm (4.88 x 2.56 x 5.00 inch)
Unit Weight		1.18 kg (2.60 lb)
Indicator	Green LED	DC OK
	Red LED	Overload
Cooling System		Convection
Terminal	Input	4 Pins (Rated 600 V / 35 A)
	Output	4 Pins (Rated 300 V / 30 A)
	Signal	2 Pins (Rated 300 V / 28 A)
Wire	Input	AWG 18-8
	Output	AWG 14*-10
	Signal	AWG 20-12
Mounting Rail		Standard TS35 DIN Rail in accordance with EN 60715
Noise (1 Meter from power supply)		Sound Pressure Level (SPL) < 25 dBA

*For AWG 14, ensure that all output terminals are connected.

Environment

Surrounding Air Temperature	Operating	-25°C to +70°C (Cold start -40°C)	
	Storage	-40°C to +85°C	
Power De-rating	Vertical Mounting	3-Phase: > 60°C de-rate power by 2.5% / °C 2-Phase: > 60°C de-rate power by 2.5% / °C	
	Horizontal Mounting	3-Phase: > 40°C de-rate power by 1.67% / °C 2-Phase: > 40°C de-rate power by 2% / °C	
Operating Humidity		5 to 95% RH (Non-Condensing)	
Operating Altitude and Over Voltage Category	OVC III	0 to 2,500 Meters (8,200 ft.)	According to IEC/EN 62477-1 / EN 60204-1 (clearance and creepage distances) and IEC 62103 (safety part)
	OVC II	2,500 to 6,000 Meters (19,680 ft.)	
		0 to 5,000 Meters (16,400 ft.)	According to ITE, IEC/EN 61010
		0 to 3,000 Meters (9,840 ft.)	According to IEC/EN 61558
Shock Test	Non-Operating	IEC 60068-2-27, Half Sine Wave: 30 G for a duration of 18 ms; 3 times per direction, 6 times in total	
Vibration	Non-Operating	IEC 60068-2-6, Sine Wave: 10-500 Hz; 3 G peak; displacement of 0.35 mm; 60 min per axis for all X, Y, Z directions	
Bump Test	Operating	IEC 60068-2-29, Half Sine Wave: 10 G for a duration of 11 ms, 1,000 times per direction, 6,000 times in total	
Pollution Degree		2	

Protections

Overvoltage	< 32 V, SELV Output, Hiccup Mode, Non-Latching (Auto-Recovery)	Refer to the details in the Function section
Overload / Overcurrent	160-195% of rated load current, Constant current, Hiccup Mode (Auto-Recovery)	Refer to the details in the Function section
Over Temperature	< 80°C Surrounding Air Temperature @ 100% load, Non-Latching (Auto-Recovery)	Refer to the details in the Function section
Short Circuit	Hiccup Mode, Non-Latching (Auto-Recovery when the fault is removed)	Load impedance ≤ 100 mOhm, refer to the details in the Function section
Transient Surge Voltage Protection	MOV (Metal Oxide Varistor)	
Internal Fuse	3 x T 3.15 A	
Degree of Protection	IP20	
Protection Against Shock	Class I with PE* connection	

*PE: Primary Earth

Reliability Data

MTBF (as per Telcordia SR-332)	750,000 hrs.	I/P: 3 x 400 Vac, O/P: 24 V, 20 A, Ta: 25°C
	500,000 hrs.	I/P: 3 x 400 Vac, O/P: 24 V, 20 A, Ta: 40°C
Expected Cap Life Time**	374,000 hrs.	I/P: 3 x 400 Vac, O/P: 24 V, 10 A, Ta: 25°C
	129,800 hrs.	I/P: 3 x 400 Vac, O/P: 24 V, 10 A, Ta: 40°C
	263,100 hrs.	I/P: 3 x 400 Vac, O/P: 24 V, 20 A, Ta: 25°C
	92,900 hrs.	I/P: 3 x 400 Vac, O/P: 24 V, 20 A, Ta: 40°C

**Earth Estimated lifetime when 24 hours operating a day and E-cap's manufacturer guarantee at 131,400 hrs. (15 years) as maximum limit of lifetime.

Safety Standards / Directives

Electrical Equipment of Machines	EN/BS EN 60204-1 (over voltage category III)	
Electrical Equipment for Use in Electrical Power Installations	IEC/EN/BS EN 62477-1 / IEC 62103	
Safety Entry Low Voltage	SELV (IEC 60950-1)	
Electrical Safety	SIQ Bauart	EN 62368-1, EN 61558-1, EN 61558-2-16, EN 61010-1, EN 61010-2-201
	UL/cUL recognized	UL 60950-1 and CSA C22.2 No. 60950-1 (File No. E191395) UL 62368-1 and CSA C22.2 No. 62368-1 (File No. E191395)
	CB scheme	IEC 60950-1, IEC 62368-1, IEC 61558-1, IEC 61558-2-16, IEC 61010-1, IEC 61010-2-201
	UKCA	BS EN 62368-1, BS EN 61558-1, BS EN 61558-2-16, BS EN 61010-1, BS EN 61010-2-201
Industrial Control Equipment	UL/cUL listed	UL 508 and CSA C22.2 No. 107.1-01 (File No. E315355)
Maritime	DNV GL	Germanischer Lloyd classified
	ABS	American Bureau for Shipping PDA Environmental category: C, EMC2
CE	In conformance with EMC Directive 2014/30/EU and Low Voltage Directive 2014/35/EU	
UKCA	In conformance with Electrical Equipment (Safety) Regulations 2016 No. 1011 and The Electromagnetic Compatibility Regulations 2016 No. 1091	
Galvanic Isolation	4.90 KVac	Input / Output
	2.88 KVac	Input / PE
	4.90 KVac	Input / DC OK relay contact*
	1.50 KVac	Output / PE
	0.50 KVac	Output / DC OK relay contact
	1.50 KVac	DC OK relay contact / PE
Isolation Resistance	> 5 MOhm	Input to Output, 500 Vdc
PE Resistance	< 0.1 Ohm	

*Recommend to connect DC OK pins together with output pins.

EMC

Emissions (CE & RE)		Generic Standards: EN/BS EN 61000-6-3 CISPR 32, EN/BS EN 55032, CISPR 11, EN/BS EN 55011, FCC Title 47: Class B		
Component Power Supply for General Use		EN/BS EN 61204-3		
Immunity		Generic Standards: EN/BS EN 55024, EN/BS EN 55035, EN 61000-6-2		
Electrostatic Discharge	IEC 61000-4-2	Level 4 Criteria A ¹⁾ Air Discharge: 15 kV Contact Discharge: 8 kV		
Radiated Field	IEC 61000-4-3	Level 3 Criteria A ¹⁾ 80 MHz – 1 GHz, 20 V/M, 80% modulation (1 kHz) 1.4 GHz – 2 GHz, 20 V/M, 80% modulation (1 kHz) 2 GHz – 2.7 GHz, 20 V/M, 80% modulation (1 kHz)		
Electrical Fast Transient / Burst	IEC 61000-4-4	Level 4 Criteria A ¹⁾ 4 kV		
Surge	IEC 61000-4-5	Level 4 Criteria A ¹⁾ Common Mode ³⁾ : 4 kV Differential Mode ⁴⁾ : 2 kV		
Conducted	IEC 61000-4-6	Level 3 Criteria A ¹⁾ 150 kHz – 80 MHz, 20 Vrms		
Power Frequency Magnetic Fields	IEC 61000-4-8	Criteria A ¹⁾ 30 A/Meter		
Voltage Dips and Interruptions	IEC 61000-4-11	0% of 3 x 380 Vac	0 Vac, 20 ms	Criteria A ¹⁾
		0% of 3 x 480 Vac	0 Vac, 20 ms	Criteria A ¹⁾
		40% of 2 x 380 Vac	152 Vac, 200 ms	Criteria B ²⁾
		40% of 2 x 480 Vac	192 Vac, 200 ms	Criteria A ¹⁾
		70% of 2 x 380 Vac	266 Vac, 500 ms	Criteria A ¹⁾
70% of 2 x 480 Vac	336 Vac, 500 ms	Criteria A ¹⁾		
0%	0 Vac, 5,000 ms	Criteria B ²⁾		
Low Energy Pulse Test (Ring Wave)	IEC 61000-4-12	Level 3 Criteria A ¹⁾ Common Mode ³⁾ : 2 kV Differential Mode ⁴⁾ : 1 kV		
Harmonic Current Emission		IEC/EN/BS EN 61000-3-2, Class A		
Voltage Fluctuation and Flicker		IEC/EN/BS EN 61000-3-3		
Voltage Sag Immunity SEMI F47 – 0706		80% of 380 Vac	304 Vac, 1,000 ms	Criteria A ¹⁾
		70% of 380 Vac	266 Vac, 500 ms	Criteria A ¹⁾
		50% of 380 Vac	190 Vac, 200 ms	Criteria A ¹⁾

1) Criteria A: Normal performance within the specification limits
2) Criteria B: Temporary degradation or loss of function which is self-recoverable
3) Asymmetrical: Common mode (Line to earth)
4) Symmetrical: Differential mode (Line to line)

Block Diagram

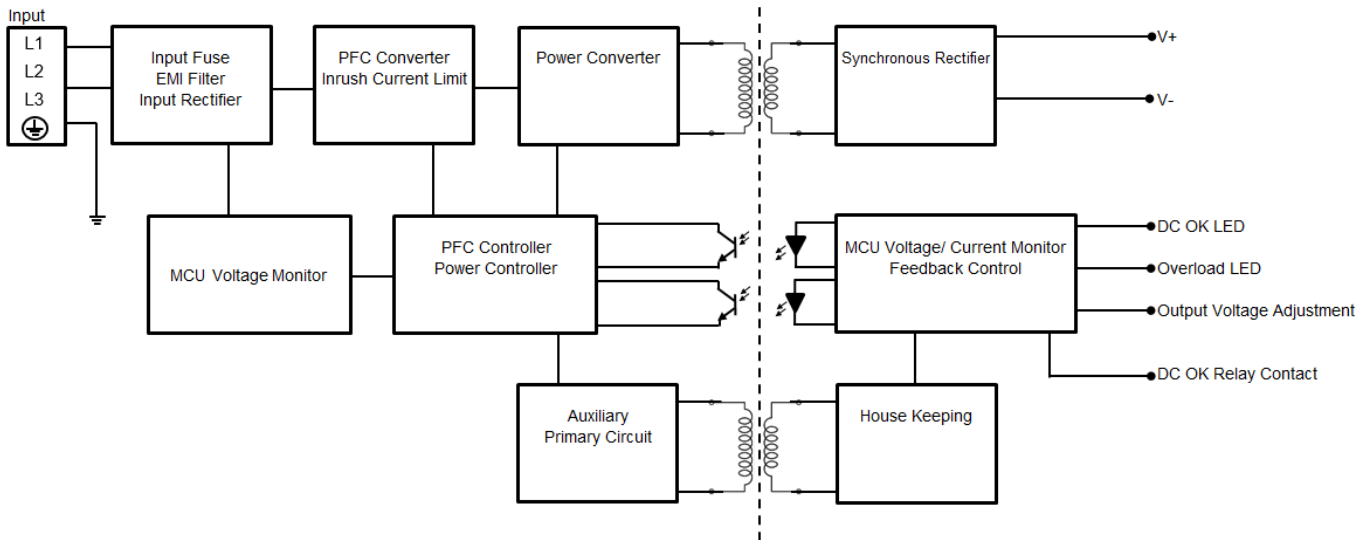

Device Description

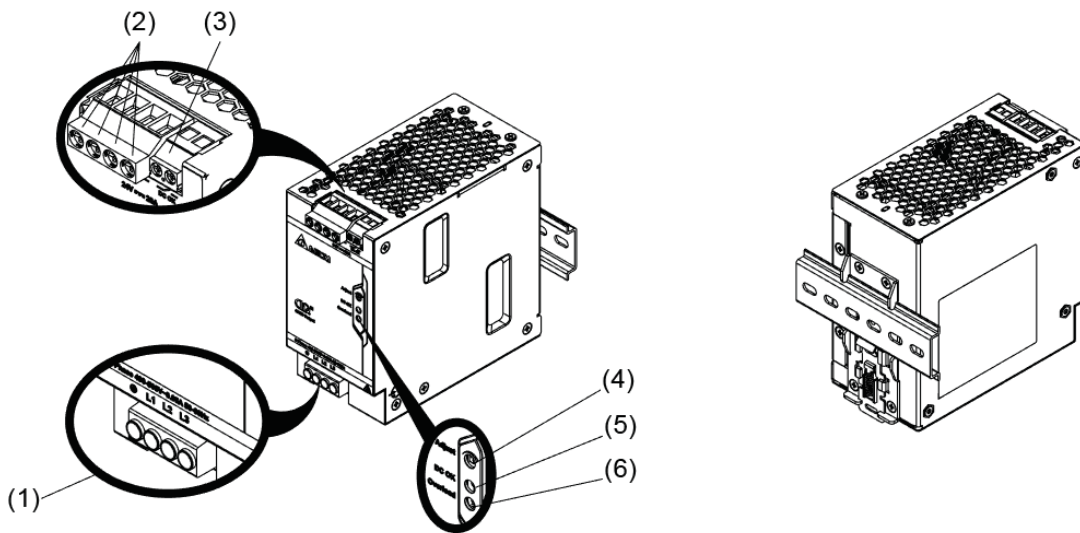

- 1) Input terminal block connector
- 2) Output terminal block connector
- 3) DC OK relay contact
- 4) DC voltage adjustment potentiometer
- 5) DC OK LED (Green)
- 6) Overload LED (Red)
- 7) Universal mounting rail system

Dimensions

L x W x D: 124.0 x 65.0 x 127.1 mm (4.88 x 2.56 x 5.00 inch)

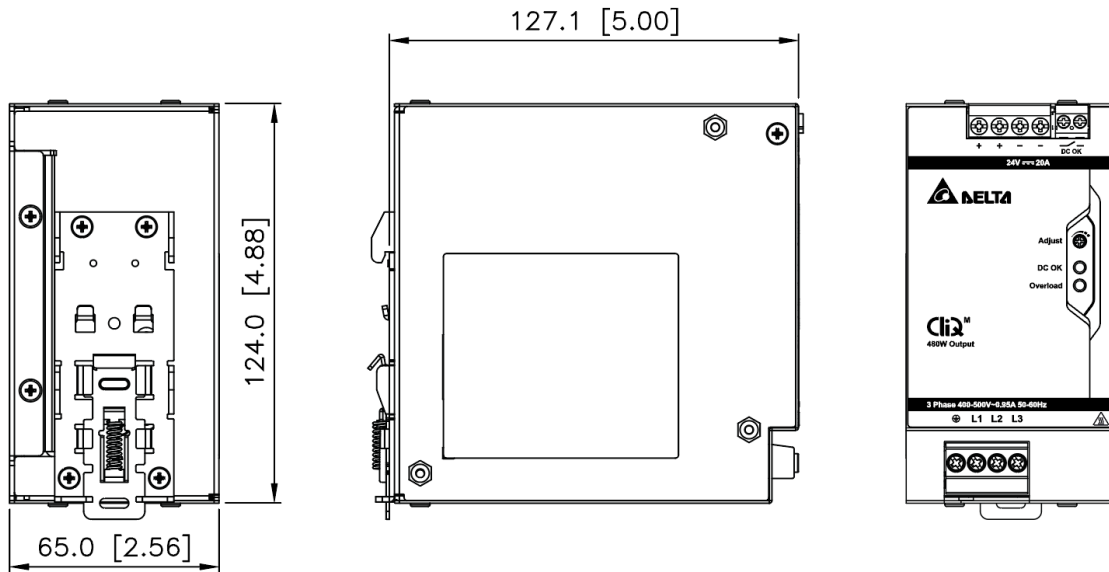

Engineering Data

Output Load De-rating VS Surrounding Air Temperature

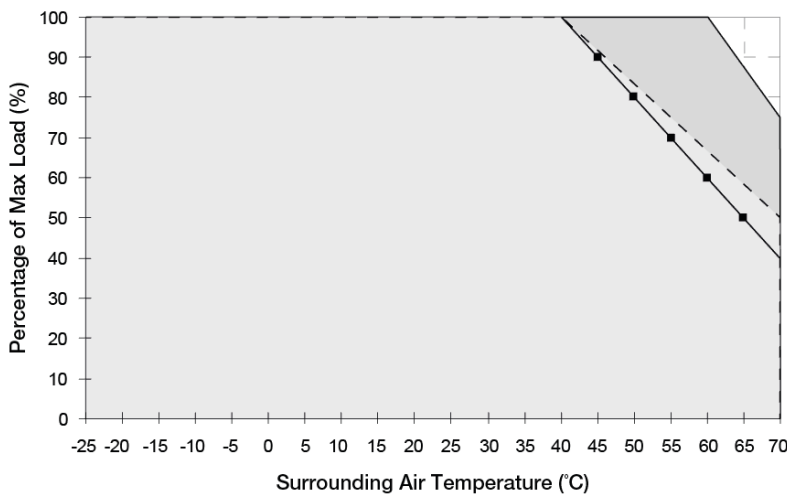

V _{in}	Vertical Mounting	Horizontal Mounting
3-Phase	—	— — —
2-Phase	—	— ◆ —

Note

1. Power supply components may degrade, or be damaged, when the power supply is continuously used outside the shaded region, refer to the graph shown in Fig. 5.
2. If the output capacity is not reduced when the surrounding air temperature exceeds its specification as defined on Page 5 under "Environment", the device will run into Over Temperature Protection. When activated, the output voltage will go into bouncing mode and will recover when the surrounding air temperature is lowered or the load is reduced as far as necessary to keep the device in working condition.
3. In order for the device to function in the manner intended, it is also necessary to keep a safety distance as recommended in the safety instructions while the device is in operation.
4. Depending on the surrounding air temperature and output load delivered by the power supply, the device can be very hot!
5. If the device has to be mounted in any other orientation, please contact info@deltapsu.com for more details.

Fig. 5 De-rating for Vertical Mounting Orientation
3-Phase > 60°C de-rate power by 2.5% / °C
2-Phase > 60°C de-rate power by 2.5% / °C

De-rating for Horizontal Mounting Orientation
3-Phase > 40°C de-rate power by 1.67% / °C
2-Phase > 40°C de-rate power by 2% / °C

Output Load De-rating VS Input Voltage

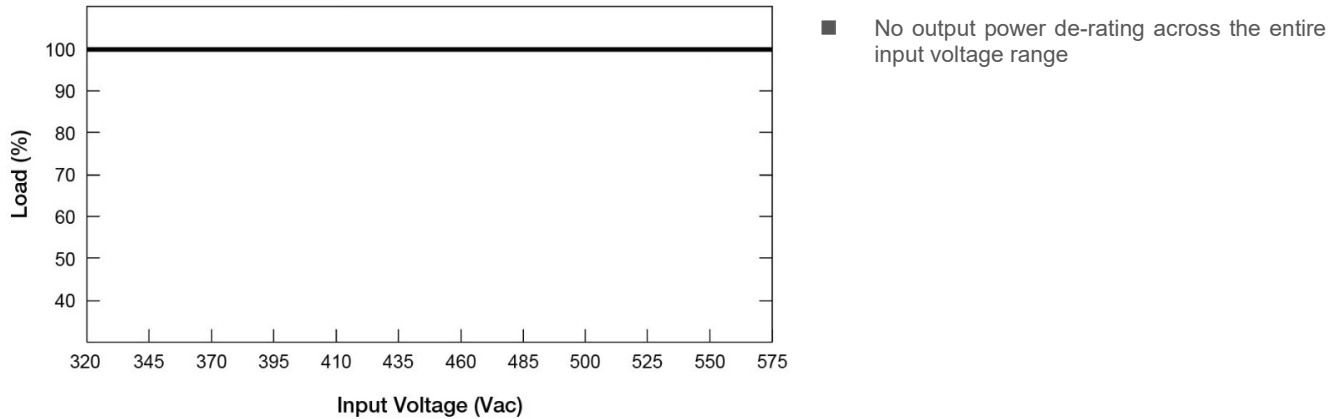

Assembly & Installation

The power supply unit (PSU) can be mounted on 35 mm DIN rails in accordance with EN 60715. For Vertical Mounting, the device should be installed with input terminal block at the bottom. For Horizontal Mounting, the device should be installed with input terminal block on the left side.

Each device is delivered ready to install.

1. Tilt the unit upwards and insert it onto the DIN rail. Snap on the DIN rail as shown in Fig. 6.1.
2. Push downwards until stopped.
3. Press against the bottom front side for locking.
4. Shake the unit slightly to ensure that it is secured.
5. To uninstall, pull or slide down the latch with screw driver as shown in Fig. 6.2. Then slide the power supply unit (PSU) in the opposite direction, release the latch and pull out the power supply unit (PSU) from the rail.

Mounting

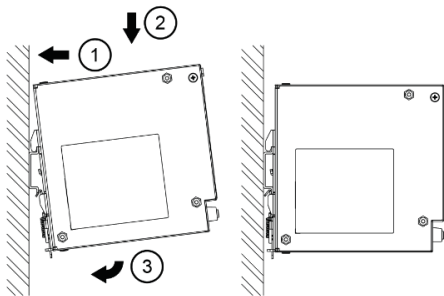

Fig. 6.1 Mounting

Dismounting

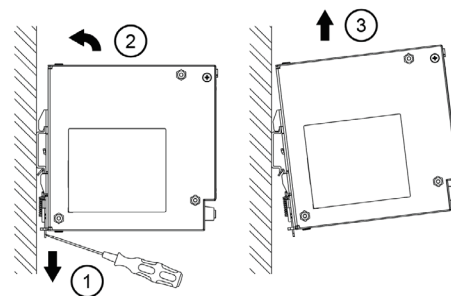

Fig. 6.2 Dismounting

In accordance to EN 60950 / UL 60950 and EN 62368 / UL 62368, flexible cables require ferrules.

Use appropriate copper cables designed to sustain operating temperature of:

1. USA: 60°C, 60°C / 75°C.
2. Canada: At least 60°C for ambient not exceeding 40°C, and 75°C for ambient exceeding 40°C.
3. IEC/EN 61010-1, IEC/EN 61010-2-201: At least 75°C for ambient not exceeding 40°C, and 90°C for ambient exceeding 40°C.

Safety Instructions

■ Vertical Mounting

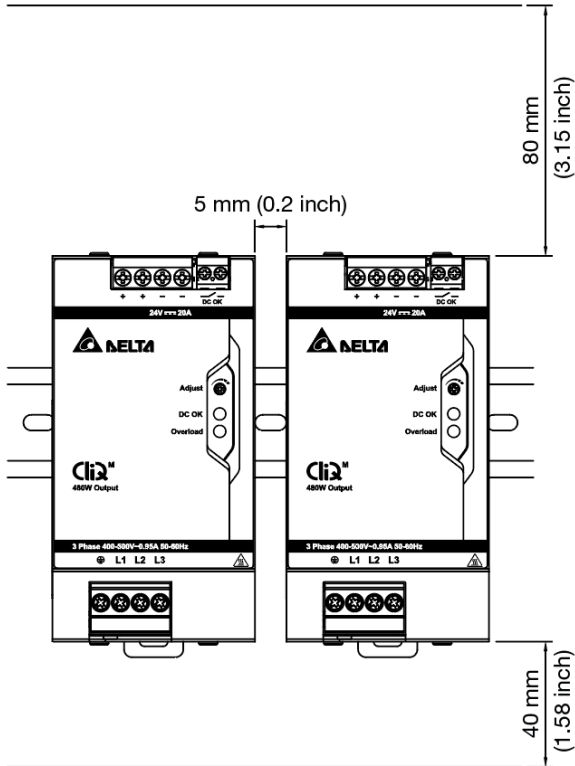

■ Horizontal Mounting

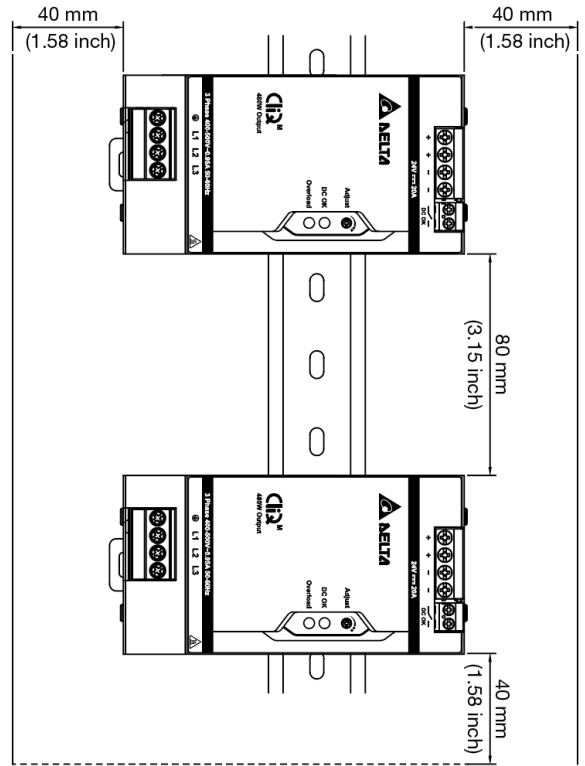

- ALWAYS switch mains of input power OFF before connecting and disconnecting the input voltage to the device. If mains are not turned OFF, there is risk of explosion / severe damage.
- If the unit is used in a manner not specified by the manufacturer, the protection provided by the equipment may be impaired.
- To guarantee sufficient convection cooling, please refer to the following instructions to ensure sufficient clearance around the device.

Vertical Mounting: 80 mm (3.15 inch) above and 40 mm (1.58 inch) below the device as well as a lateral distance of 5 mm (0.2 inch) to other units. In case the adjacent device is a heat source, the lateral distance will be 50 mm (1.97 inch).

Horizontal Mounting: 80 mm (3.15 inch) above and 40 mm (1.58 inch) below the device as well as a lateral distance of 40 mm (1.58 inch) to other units.

- The external enclosure where the unit will be installed shall meet the requirements for mechanical, electrical and fire enclosure.
- Note that the enclosure of the device can become very hot depending on the surrounding air temperature and output load connected to the device. Risk of burns!
- The main power must be turned off before connecting or disconnecting wires to the terminals.
- DO NOT insert any objects into the unit.
- Dangerous voltages present for at least 5 minutes after disconnected all sources of power.
- The power supplies are built in units and must be installed in a cabinet or room (condensation free environment and indoor location) that is relatively free of conductive contaminants.
- The power supply shall be installed within service maintenance area only; and the cord connector or attachment plug shall not be disconnected while the power supply and system are still running.

Functions

DC OK Relay Contacts and LED Indicator Characteristics

DC OK Relay Contacts Status	Characteristics
Contact closes	The output voltage reaches 95% of its steady state set value. The contact will close within 1,000 ms.
Contact opens	The output voltage dip lower than 90% of its steady state set value: <ul style="list-style-type: none"> Output voltage dip duration less than 2 ms will be ignored. Output voltage dip duration more than 2 ms. The contact will open within 15 ms and remain open for an extended duration up to 350 ms max.
Contact re-closes	The output voltage reaches 90% of its steady state set value. The contact will close in 350 ms max.

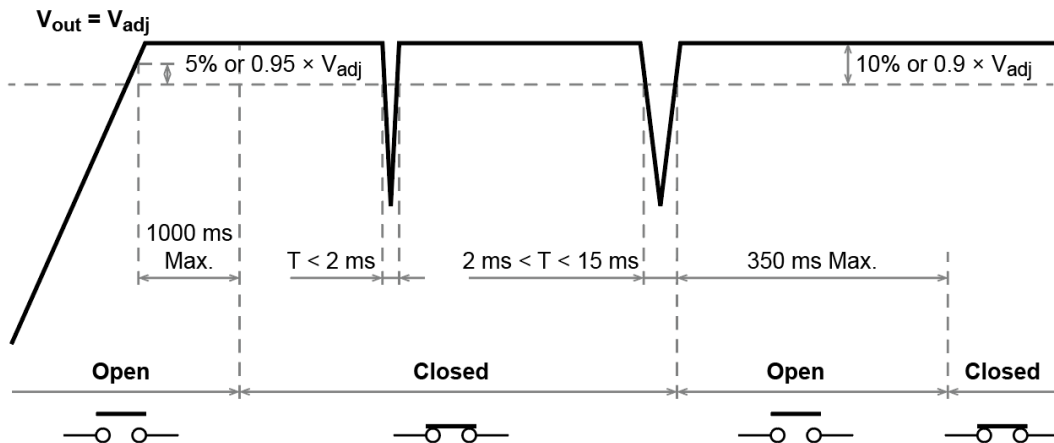

Operating Status	DC OK (Green LED)	Overload (Red LED)	DC OK Relay Contact
Normal Operation	ON	OFF	Closed
During Power Boost	ON	OFF	Closed
Overload ($V_{out} \leq 90\%$ of adjusted voltage)	OFF	Flashing	Open
Output Short Circuit	OFF	Flashing	Open
Over Temperature	OFF	Flashing	Open
No Input Power	OFF	OFF	Open

■ Graph illustrating the Start-up Time, Rise Time, and Hold-up Time

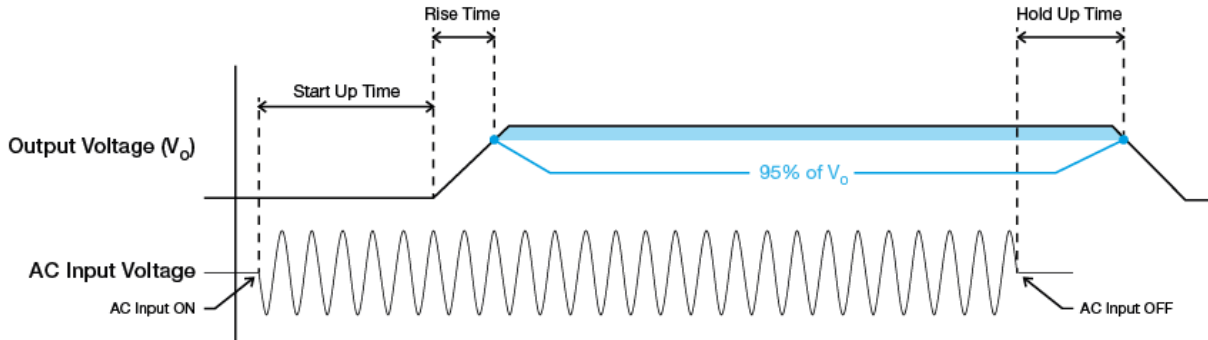

Start-up Time

The time required for the output voltage before output voltage rise up, after the input voltage is applied.

Rise Time

The time required for the output voltage to change from 0% to 95% of its final steady state set value.

Hold-up Time

Time between the collapse of the AC input voltage, and the output falling to 95% of its steady state set value.

Inrush Current

Inrush current is the peak, instantaneous, input current measured and, occurs when the input voltage is first applied. For AC input voltages, the maximum peak value of inrush current will occur during the first half cycle of the applied AC voltage. This peak value decreases exponentially during subsequent cycles of AC voltage.

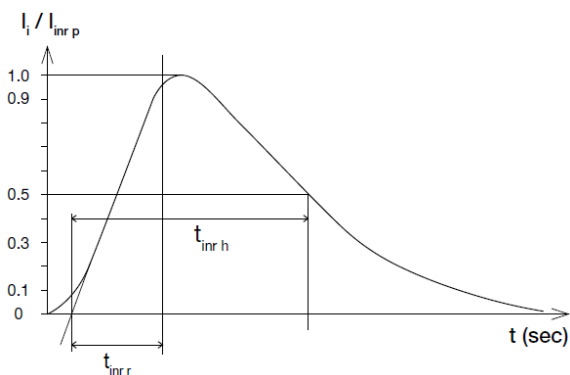

Dynamic Response

The power supply output voltage will remain within $\pm 5\%$ of its steady state value, when subjected to a dynamic load from 1.5% to 100% of its rated current.

■ 50% duty cycle / 5 Hz to 1 kHz

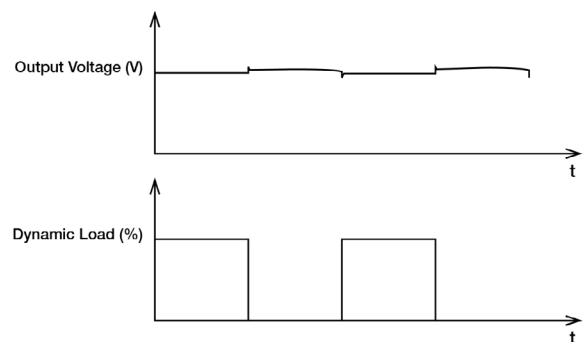

Overvoltage Protection (Auto-Recovery)

The power supply's overvoltage circuit will be activated when its internal feedback circuit fails. The output voltage shall not exceed its specifications defined on Page 6 under "Protections".

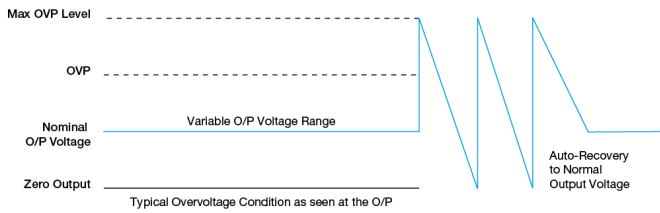

Overload & Overcurrent Protections (Auto-Recovery)

The power supply's Overload (OLP) and Overcurrent (OCP) Protections will be activated when output current (I_o) is $> 150\%$ of maximum rated load (I_o Max). When this occurs, the output current will limit to 22 A typ. (refer to A below) and output voltage (V_o) will start to droop. Once V_o is below approximately 18 Vdc typ., the power supply will start to operate in "Hiccup mode" as described in short circuit protection. The power supply will recover once the fault condition due to OLP or OCP is removed, then I_o is back within its specified limits.

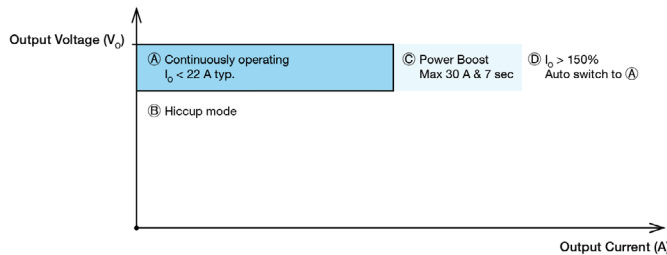

Over Temperature Protection (Auto-Recovery)

As described in load de-rating section, the power supply also has Over Temperature Protection (OTP). In the event of a higher operating temperature at 100% load, the power supply will run into OTP when the operating temperature is beyond what is recommended in the de-rating graph. When activated, the output voltage will go into bouncing mode until the temperature drops to its normal operating temperature as recommended in the de-rating graph.

Short Circuit Protection (Auto-Recovery)

The power supply's output Short Circuit Protection function also provides protection against short circuits. When a short circuit is applied, the output current will start to operate in "Hiccup mode". The power supply will return to normal operation after the short circuit is removed.

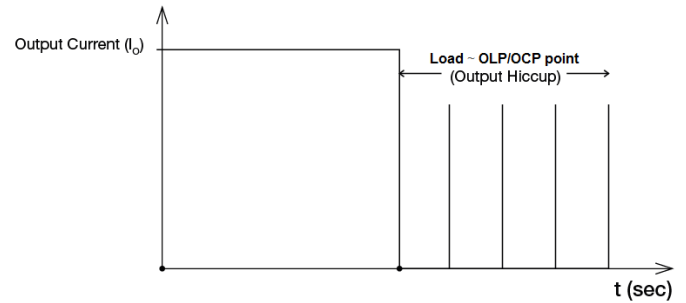

Line Input Over Voltage Surge (Auto-Recovery)

The power supply's input over voltage protection will be activated when input voltage exceeds 3×635 Vac. In such occurrence, the power supply will shut down output voltage (V_o). The power supply will recover once the input voltage is decreased to lower than 3×600 Vac and V_o shall be back within the specifications.

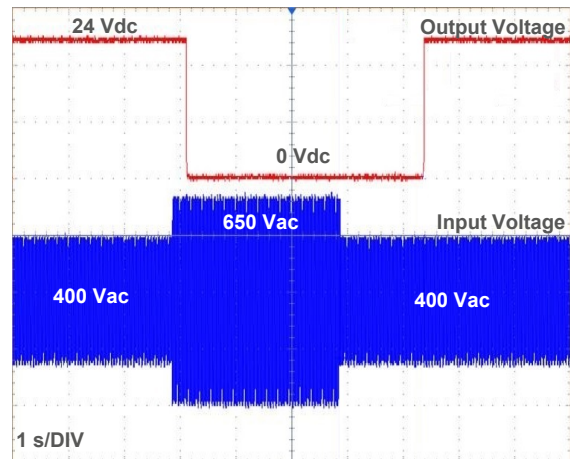

Power Boost

Power Boost is the reserve power available constantly that allows reliable startup to support sudden and short spike of loads with high inrush current typically during turn on to remove the need of more expensive higher rated power supply unit. After the output has reached its steady state set value, the power supply can support surge loads with a higher short-term power demand up to 150% of maximum rated load ($I_{O Max}$), for a maximum duration of 7 seconds. If the power boost lasts longer than maximum duration, the output current will limit to 22 A typ. and V_O (output voltage) will start to droop, refer to the details in overload & overcurrent protections and the next Power Boost will be available after power boost recovery time defined on Page 4. In order to avoid this, need to maintain the duty cycle & recovery time to ensure that average (R.M.S) output power shall not exceed the continuous maximum, see duty cycle calculation below.

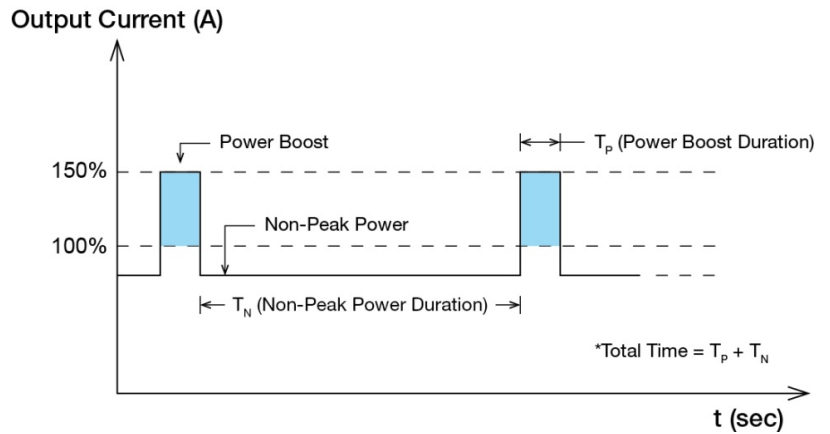

Fig. 7 Duty Cycle Calculation

$$\text{Duty cycle (\%)} = \frac{T_P}{\text{Total Time}}$$

$$\text{Average Output Power (P}_{Avg}\text{)} = \frac{(\text{Power Boost} \times T_P) + (\text{Non-Peak Power} \times T_N)}{\text{Total Time}}$$

OR

$$\text{Non-Peak Power} = \frac{(\text{P}_{Avg} \times \text{Total Time}) - (\text{Power Boost} \times T_P)}{T_N}$$

■ An example of Power Boost and Average Output Power

Power Boost	Peak Power (W _P)	Power Boost Duration (T _P)	Duty Cycle	Non-Peak Power (W _N)	Non-Peak Power Duration (T _N)	Total Time (T)
150%	720	1 sec	10%	187 W	9 sec	10 sec
150%	720	5 sec	30%	31 W	11.5 sec	16.5 sec
125%	600	1 sec	10%	200 W	9 sec	10 sec
125%	600	5 sec	30%	83 W	11.5 sec	16.5 sec

Advanced Power Boost (APB)

With multiple loads connected in a system and due to one of fault load a large inrush current is drawn (demanded), this will be detected by APB. This APB can trip the external output protection device with appropriate rating based on system load. Thus preventing the system from shutting down while other connected current paths continue to operate without interruption.

The following waveforms demonstrate the behavior.

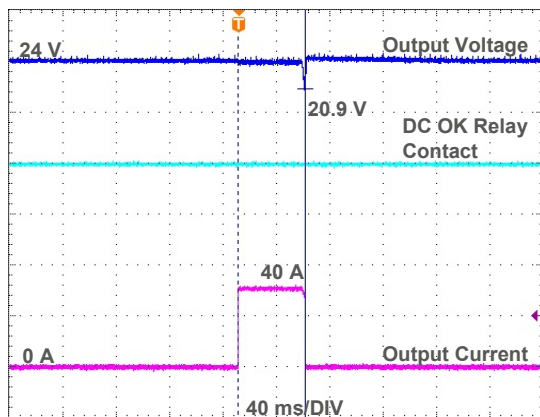

Fig. 8.1 APB 200% of nominal output current for 50 ms

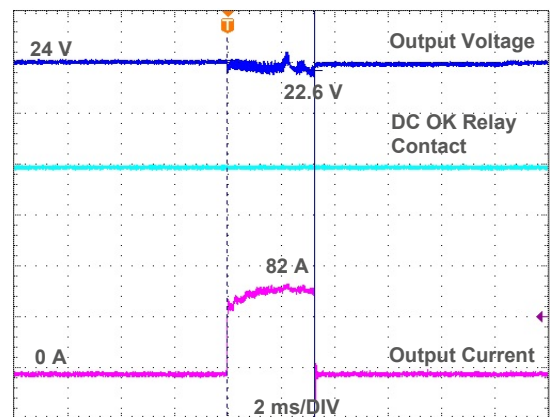

Fig. 8.2 APB 400% of nominal output current for 2 ms

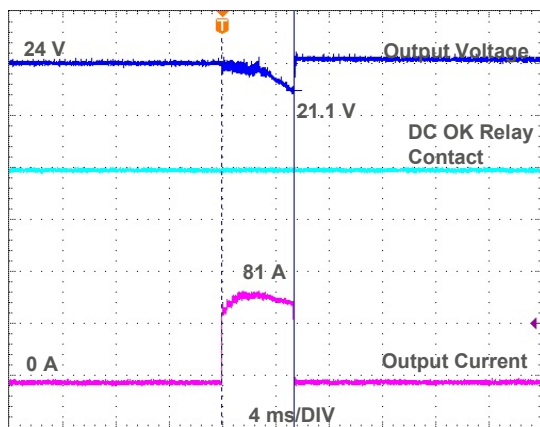

Fig. 8.3 APB 400% of nominal output current for 5 ms

External Input Protection Device

The unit is protected at the L pin, with an internal fuse that cannot be replaced. The power supply has been tested and approved on 20 A (UL) and 16 A (IEC) branch circuits without additional protection device. An external protection device is only required if the supplying branch has an ampacity greater than above. Thus, if an external protective device is necessary, or, utilized, please refer a minimum value in instruction sheet with 6 A B- or 3 A C- characteristic breaker.

Operating Mode

■ Redundant Operation

In order to ensure proper redundant operation for the power supply units (PSUs), the output voltage difference between the two units must be kept at 0.45~0.50 V for these 24 V supplies. Follow simple steps given below to set them up for the redundant operation:

Step 1.

Measure output voltage of PSU 1 and PSU 2. If PSU 1 is the master unit, then V_O of PSU 1 must be higher than PSU 2. In order to set the output voltage, individually connect each power supply to 50% of rated load at any line voltage, and set the PSU 1 and PSU 2 output voltage.

Step 2.

Connect the power supply units PSU 1 and PSU 2 to V_{in1} & V_{in2} , respectively, of the DRR-20N (or 20A) module shown on the Fig 9.

Step 3.

Connect the system load from V_{out} . Please note that output voltage V_{out} from DRR module will be = V_O (output voltage of power supply) – V_{drop}^* (in DRR module).

* V_{drop} will vary from 0.60 V to 0.90 V (Typical 0.65 V) depending on the load current and surrounding air temperature.

■ Parallel Operation

The power supply units (PSUs) can also be used for parallel operation in order to increase the output power. The difference in output voltage between the two units must be kept to within 25 mV of each other. This difference must be verified with the same output load connected independently to each unit.

Parameters such as EMI, inrush current, leakage current, PARD, start up time will be different from those on the datasheet, when two units are connected in parallel. The user will need to verify that any differences will still allow the two power supplies connected in parallel will work properly in their product/application.

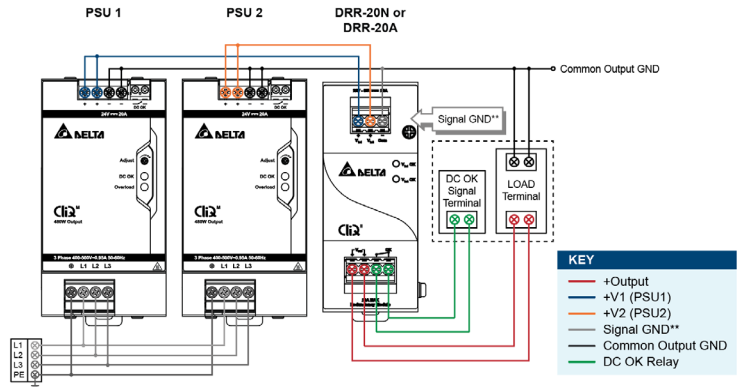

***The Signal GND in the DRR module is for the built-in LED and DC OK signals. The Output GND terminals from the two PSU's do not need to be connected to the Signal GND terminal.

Fig. 9 Redundant Operation Connection Diagram

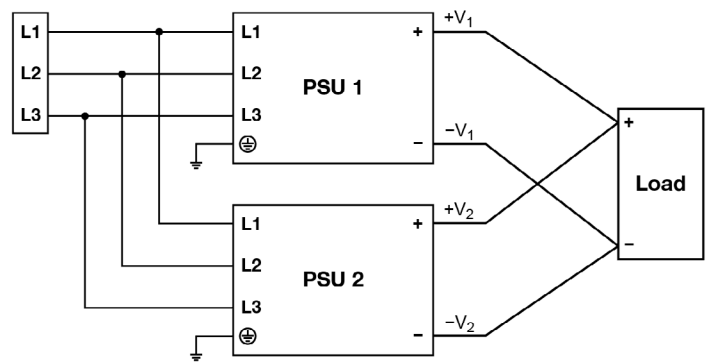

Fig. 10 Parallel Operation Connection Diagram

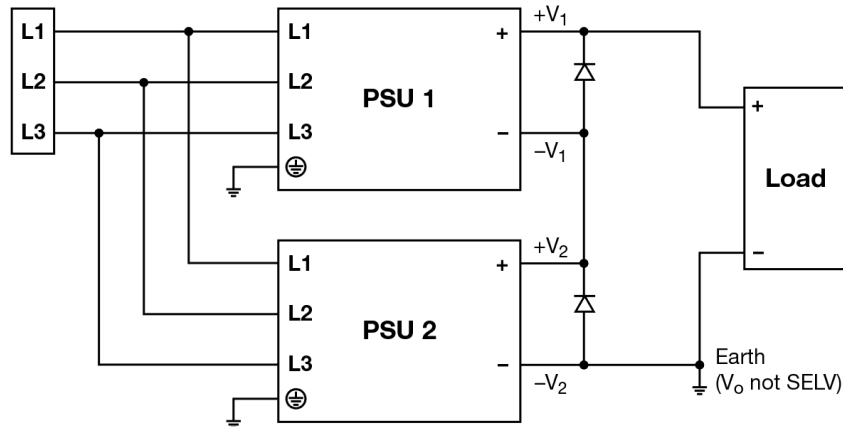
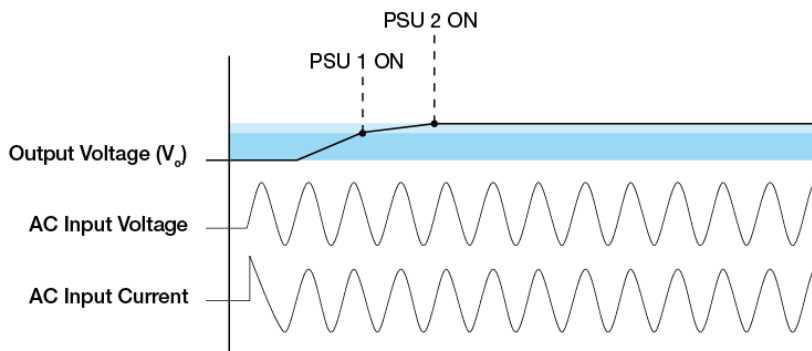

Fig. 11 Series Operation Connection Diagram

■ Series Operation

Delta's CliQ M can be connected in series to increase the output voltage as shown in figure above. Only power supply from the same product series, and with the same rated output current, can be used. The maximum load current should not exceed the smallest rated output current. Any number of power supplies can be connected in series. User must note that an output voltage > 60 Vdc will not meet SELV requirements and could be dangerous to user, the total voltage shall not exceed 150 Vdc. Installation a protection against the touching is a must and connect the output ground to earth when output voltage is not SELV. A diode in reverse bias must be added across output terminals of each power supply, this is to prevent -V voltage being applied to other power supply in fault conditions such as short circuit across load. During the short circuit -V₁ & +V₁ will come across +V₂ & -V₂ which means connecting 2 power supplies in opposite polarity and may cause damage to power supply. With reverse bias diodes in place the voltage across each power supply will be restricted to one diode drop – approximately 0.7 V to 1.0 V. It is recommended to provide sufficient voltage de-rating for diodes with 2 times the voltage rating of series output voltage. E.g. the two 24 V power supplies are connected in series, the total voltage is 48 volts. Hence, recommended to use diodes with reverse voltage rating of 2x48=96 volts. Therefore diodes with reverse voltage rating of 100 volts can be used.

During the short circuit condition, the current through diodes will be large, hence it is recommended that diodes to be least twice the current rating of the power supply.



The turn ON would be non-monotonic as the power supply with the fastest startup time and rise time will turn on first. As a result, the combined output voltage waveform of the 2 power supplies connected in series will include a step.

User must consider to verify parameters such as EMI, inrush current, leakage current, PARD, start up time would differ from datasheet numbers as multiple power supplies in series.

Others

Conformal Coating

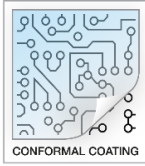

The Protective Coating Technology

Delta Electronics Group has designed the perfect dipping technique which penetrates everywhere including under device, and prevents leakage. The conformal coating dipping can be applied to PCBAs or circuit board. The coating preserves the performance of precision electronic primarily by preventing ionizable contaminants such as salt from reaching circuit nodes, where the material slumps around sharp edges. This can be a problem especially in highly conversing atmosphere.

PFC – Norm EN 61000-3-2

Line Current Harmonic content

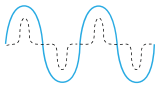

Typically, the input current waveform is not sinusoidal due to the periodic peak charging of the input capacitor. In industrial environments, compliance with EN 61000-3-2 is only necessary under special conditions. Complying to this standard can have some technical drawbacks, such as lower efficiency; and, can also result in higher product cost. Frequently, the user does not profit from compliance to this standard; therefore, it is important to know whether it is mandatory to meet this standard for a specific application.