

150AAS19 F/B



Highlights & Features

- Meet Efficiency Level VI
- Safety Approvals to IEC 60601-1 & IEC 62368-1
- Compliant with IEC 60601-1-2 4th Ed. Requirements
- Low touch current (<0.1 mA Normal & <0.3 mA single fault)
- Over-Voltage/Load/Temperature & Short Circuit protections
- 1 Million Hours MTBF
- 2 × MOPP isolation
- 3 years warranty

Safety Standards



CB Certified for worldwide use

Model Number: MDS-150AAS19 F/B
Unit Weight: 1.1 kg (39.6 ounces)
Dimensions (L x W x H): 170.0 x 85.0 x 40.0 mm
 (6.7 x 3.3 x 1.6 in)

General Description

The MDS series of external power supply come with universal AC input at 90 Vac to 264 Vac. Other features include low touch current, risk management report available and the electric shock protection comply with 2 x MOPP. The MDS series is certified for EMC standards according to EN/BS EN 55011 for industrial, scientific and medical (ISM) radio-frequency equipment and EN/BS EN 55032 for Industrial Technology Equipment (ITE) radio-frequency equipment.

The MDS series come with both medical and ITE safety approvals including UL/cUL/CCC/CE and CB certification and are fully compliant with RoHS Directive for environmental protection.

Model Information

Medical AC-DC Adapter

| Model Number | Input Voltage Range | Output Voltage | Output Current |
|-----------------|---------------------|----------------|----------------|
| MDS-150AAS19 BA | 90-264 Vac | 19 Vdc | 7.89 A |
| MDS-150AAS19 FA | | | |

Model Numbering

| | | | | | CC Code | |
|-------------------------------|-----------------------------------|-------------|--------------------------|--------------------------|---|---|
| MDS – | 150 | AAS | 19 | <input type="checkbox"/> | <input type="checkbox"/> | |
| Delta Medical Desktop Adapter | Max wattage in the product series | Family Code | Output Voltage 19 – 19 V | Blank | Protection Against Shock F: Class I B: Class II with functional Earth | Plug, Molding type and others A: 4 Pin Din |
| Refer to Page 7. | | | | | | |

Specifications

Input Ratings / Characteristics

| | |
|--------------------------|--|
| Nominal Input Voltage | 100-240 Vac |
| Input Voltage Range | 90-264 Vac |
| Nominal Input Frequency | 50-60 Hz |
| Input Frequency Range | 47-63 Hz |
| Input Current (max.) | 4 A @ 115 Vac, 2 A @ 230 Vac |
| Efficiency (typ.) | 90.5%, Reference Fig. 1 |
| Average Efficiency (min) | 88% @ 115 Vac and 230 Vac |
| Standby Power (max.) | 0.21 W @ 115 Vac and 230 Vac |
| Inrush Current (typ.) | 50 A @ 115 Vac, 100 A @ 230 Vac |
| Touch Current (max.) | 0.1 mA @ 264 Vac NC ¹⁾ , 0.3 mA @ 264 Vac SFC ²⁾ |

1) NC: normal condition

2) SFC: single fault condition

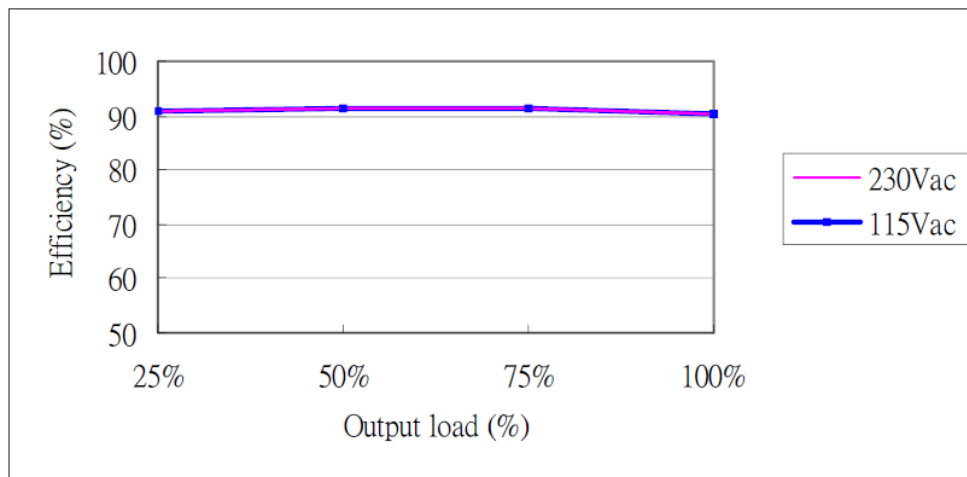

Fig. 1 Efficiency versus output load

Output Ratings / Characteristics

| | |
|---|--|
| Nominal Output Voltage | 19 Vdc |
| Total Regulation | ± 5% |
| Output Current | 7.89 A |
| Output Power | 150 W |
| Line Regulation (max) | ± 0.5% |
| Load Regulation (max) | ± 4.5% |
| Ripple & Noise (max) | 190 mV pk-pk @ Full load, Reference Fig. 2 |
| Start-up Time (max) | 3000 ms |
| Hold-up Time (min) | 20 ms @ 115 Vac & 230 Vac |
| Dynamic Response (Overshoot & Undershoot O/P Voltage) | ± 5% @ 50-100% load |

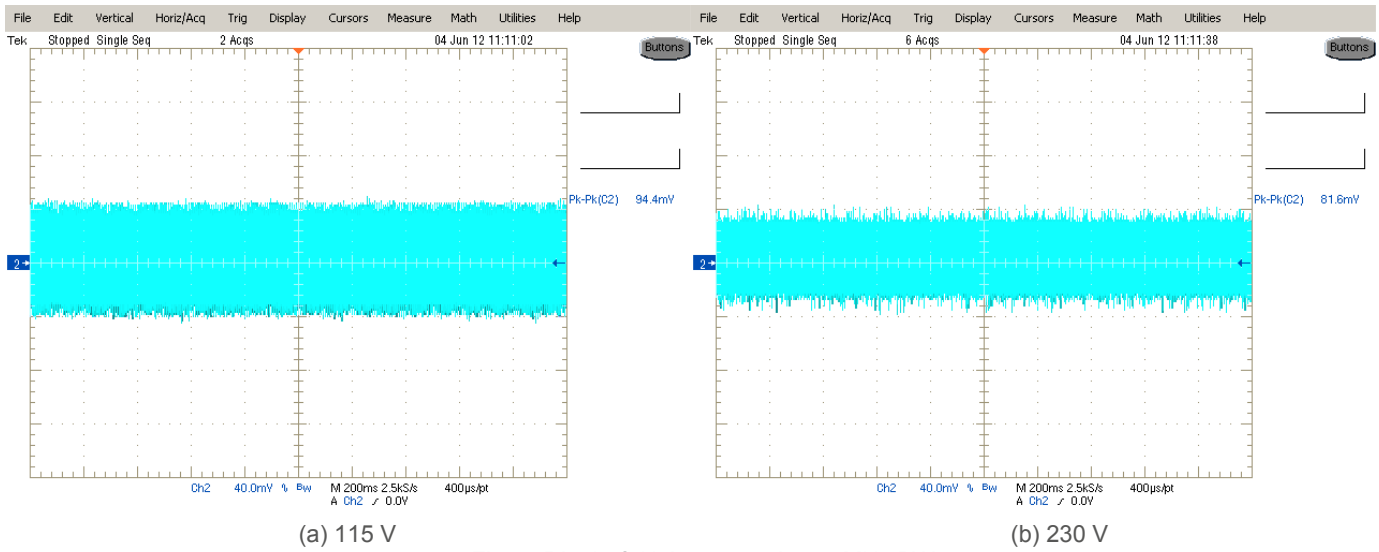
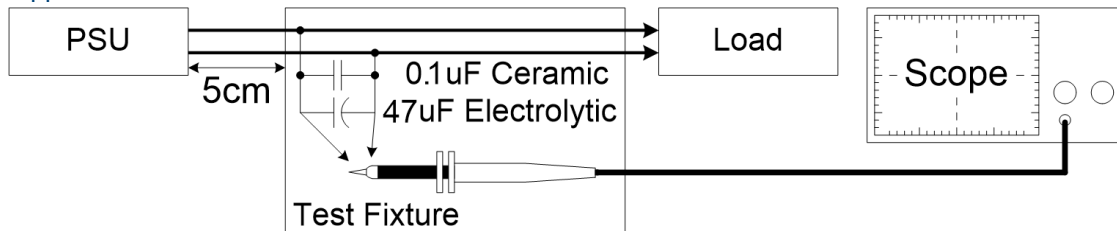

Fig. 2 Ripple & Noise example, 20 MHz BW

Ripple & Noise measurement circuit



Mechanical

| | | |
|------------------------|---|------------|
| Case Chassis | PC | |
| Case Cover | PC | |
| Dimensions (L x W x H) | 170.0 x 85.0 x 40.0 mm (6.7 x 3.3 x 1.6 in) | |
| Unit Weight | 1.1 kg (39.6 ounces) | |
| Indicator | NA | |
| Cooling System | NA | |
| Terminal | Input | C14 socket |
| | Output | 4 Pin Din |

Environment

| | | |
|-----------------------------|-----------|--|
| Surrounding Air Temperature | Operating | 0°C to +40°C |
| | Storage | -40°C to +85°C |
| Operating Humidity | | 10-90% RH (Non-Condensing) |
| Operating Altitude | | 3,000 meters (9842.52 feet) |
| Shock Test (Non-Operating) | | 50 G, 11 ms, 3 shocks for each direction |
| Vibration (Non-Operating) | | 5-500 Hz, 2.09 Grms, 20 minute for each three axis |

Protections

| | |
|--------------------------------|--|
| Overvoltage (max) | 150%, Latch Mode |
| Over load / Over current (max) | 130% of rated load current, Hiccup Mode, (Non-Latching, Auto-Recovery) |
| Over Temperature | Hiccup Mode, (Non-Latching, Auto-Recovery) |
| Short Circuit | Hiccup Mode, (Non-Latching, Auto-Recovery) |
| Protection Against Shock | Class I for F series |
| | Class II with functional earth for B series |

Reliability Data

| | |
|-------------|--|
| MTBF (typ.) | 1 Million Hours based on Telecordia SR-332 |
|-------------|--|

Safety Standards / Directives

| | | |
|--------------------|--|----------|
| Medical Safety | IEC 60601-1 CB report, EN 60601-1 CAN/CSA-C22.2 No. 60601-1, ANSI/AAMI ES 60601-1 | |
| ITE Safety | IEC 60950-1, IEC 62368-1, GB 4943.1, GB/T 9254.1, GB 17625.1 | |
| CE | In conformance with EMC Directive 2014/30/EU and Low Voltage Directive 2014/35/EU EN 60601-1 & EN 60601-1-2 | |
| UKCA | In conformance with Electrical Equipment (Safety) Regulations 2016, and Electromagnetic Compatibility Regulations 2016, Medical Devices Regulations 2002(UK MDR 2002) | |
| Galvanic Isolation | Input to Output | 4000 Vac |
| | Input to Ground | 1500 Vac |
| | Output to Ground | 500 Vac |

EMC (Compliant with IEC 60601-1-2 4th Ed. Requirements)

| | | |
|-----------------------------------|----------------|--|
| EMC / Emissions | | EN/BS EN 55011, EN/BS EN 55032, FCC Title 47:Class B |
| Harmonic Current Emissions | IEC 61000-3-2 | Meet Class A & D limit |
| Voltage Flicker | IEC 61000-3-3 | |
| Immunity to | | |
| Electrostatic Discharge | IEC 61000-4-2 | Level 4 Criteria A ¹⁾ Air Discharge: 15 kV Contact Discharge: 8 kV |
| Radiated Field | IEC 61000-4-3 | Criteria B ²⁾ 80 MHz-2700 MHz, 10 V/m AM modulation 385 MHz-5785 MHz, 28 V/m Pulse mode and other modulation |
| Electrical Fast Transient / Burst | IEC 61000-4-4 | Level 3 Criteria A ¹⁾ : 2 kV |
| Surge | IEC 61000-4-5 | Level 3 Criteria A ¹⁾ Common Mode ³⁾ : 2 kV Differential Mode ⁴⁾ : 1 kV |
| Conducted | IEC 61000-4-6 | Level 2 Criteria A ¹⁾ 150 kHz-80 MHz, 3 Vrms, 6 Vrms at ISM bands and Amateur radio bands |
| Power Frequency Magnetic Fields | IEC 61000-4-8 | Criteria A ¹⁾ Magnetic field strength 30 A/m |
| Voltage Dips | IEC 61000-4-11 | Criteria A ¹⁾ 0% U _T , 0.5 cycle (10 ms), 0°/45°/90°/135°/180°/225°/270°/315°/360° Criteria A ¹⁾ 0% U _T , 1 cycle (20 ms), 0° Criteria A ¹⁾ 70% U _T , 25 cycle (500 ms), 0° Criteria B ²⁾ 0% U _T , 250 cycle (5000 ms), 0° |

1) Criteria A: Normal performance within the specification limits

2) Criteria B: Output out of regulation, or shuts down during test. Automatically restore to normal operation after test.

3) Asymmetrical: Common mode (Line to earth)

4) Symmetrical: Differential mode (Line to line)

Block Diagram

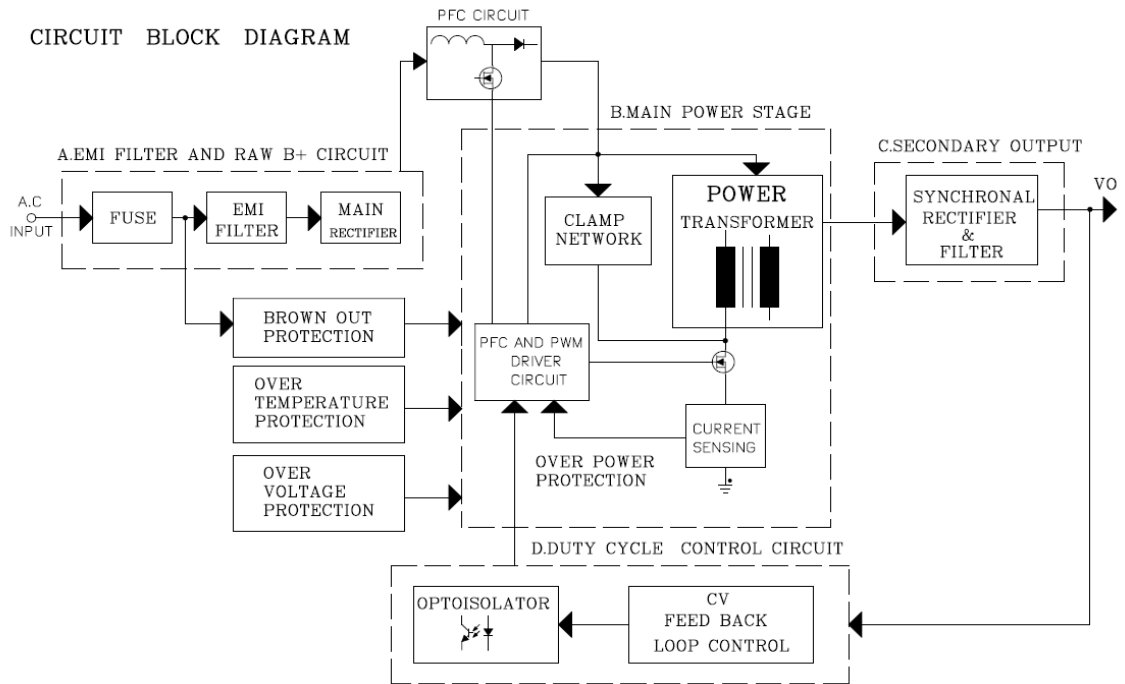

Dimensions

L x W x H: 170.0 x 85.0 x 40.0 mm (6.7 x 3.3 x 1.6 in)

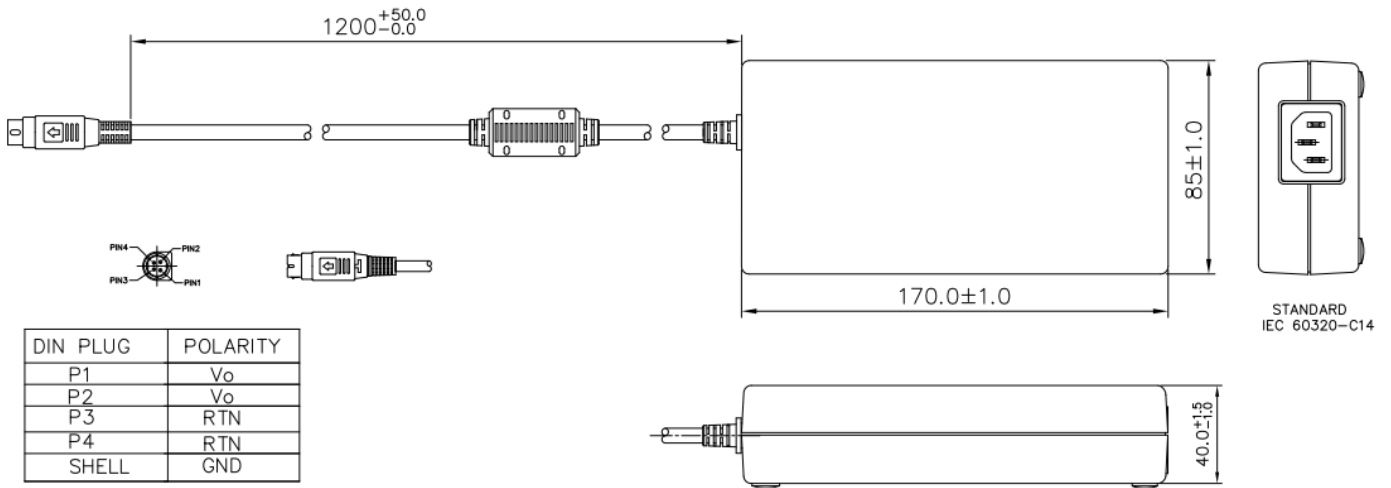

| DIN PLUG | POLARITY |
|----------|----------|
| P1 | Vo |
| P2 | Vo |
| P3 | RTN |
| P4 | RTN |
| SHELL | GND |

Notes:
 Dimension are in mm

| Item | Device Description |
|------|--------------------|
| 1 | Cover |
| 2 | Chassis |
| 3 | Power Cord |
| 4 | Socket |

DC Output Plug:

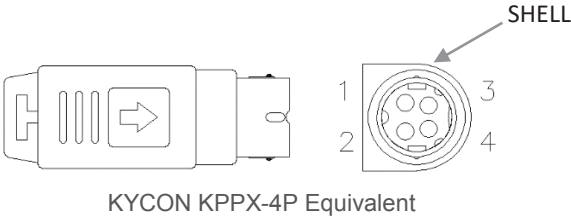
| Mini DIN 4 Pins with Lock (Male) | CC Code | Cable Length | Pin Assignment | |
|---|---------|--------------|----------------|-----|
|  <p>KYCON KPPX-4P Equivalent</p> | BA | 1.2 m | 1 | +Vo |
| | | | 2 | +Vo |
| | | | 3 | -Vo |
| | | | 4 | -Vo |
| | | | Shell | - |

Functions

Start-up Time

The time required for the output voltage (V_o) to reach 90% of its set value, after the input AC voltage is applied.

Rise Time

The time required for the output voltage (V_o) to change from 10% to 90% of its steady state value.

Hold-up Time

Hold up time is the time when the AC input collapses and output voltage retains regulation for a certain period of time. The time required for the output to reach 95% of its set value, after the input voltage is removed.

■ **Graph illustrating the Start-up Time, Rise Time, and Hold-up Time**

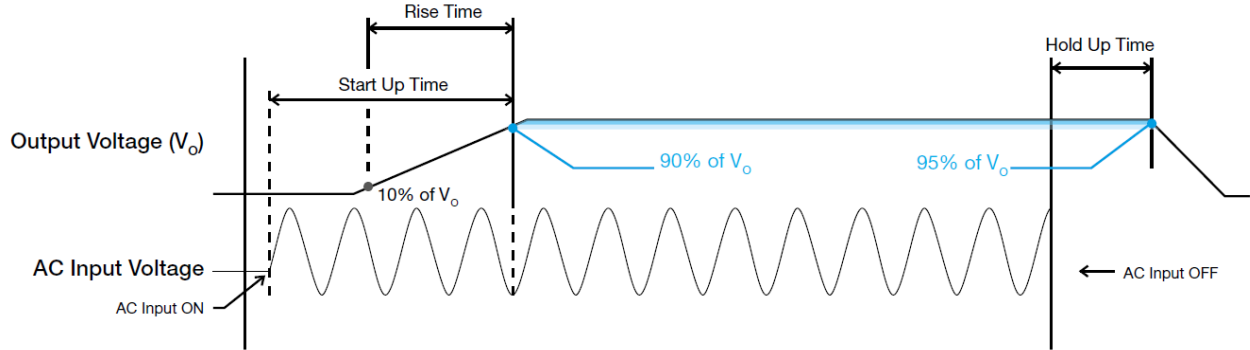

Dynamic Response

The power supply output voltage will remain within $\pm 5\%$ of its steady state value, when subjected to a dynamic load change from 50 to 100% of its rated current.

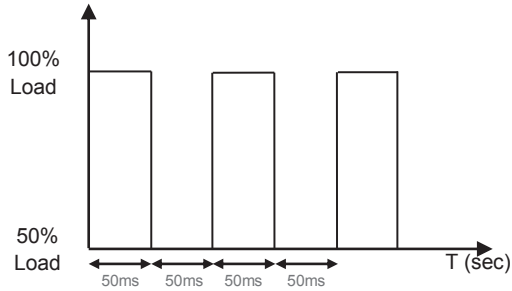

Inrush Current

Inrush current is the input current that occurs when the input voltage is first applied. For AC input voltages, the maximum peak value of inrush current will occur during the first half cycle of the applied AC voltage. This peak value decreases exponentially during subsequent cycles of AC voltage.

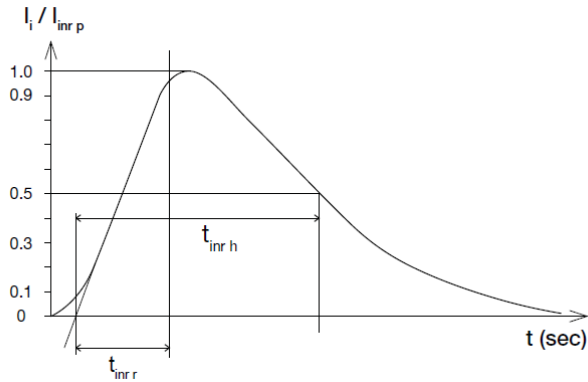

Overvoltage Protection

The power supply's overvoltage circuit will be activated when its internal feedback circuit fails. The output voltage shall not exceed its specifications defined on Page 4 under "Protections". Power supply will latch off, and require removal/re-application of input AC voltage in order to restart.

Short Circuit Protection

The power supply's output OLP/OCP function also provides protection against short circuits. When a short circuit is applied, the output current will operate in "Hiccup mode", as shown in the illustration in the OLP/OCP section on this page. The power supply will return to normal operation after the short circuit is removed.

Overload & Over current Protections

The power supply's Overload (OLP) and Over current (OCP) Protections will be activated when output current is between 110% and 130% of I_o (Max load). Upon such an occurrence, V_o will start to drop. Once the power supply has reached its maximum power limit, the protection will be activated, and the power supply will go into "Hiccup mode" (Auto-Recovery). The power supply will recover once the fault condition causing the OLP and OCP is removed and I_o is back within the specified limit.

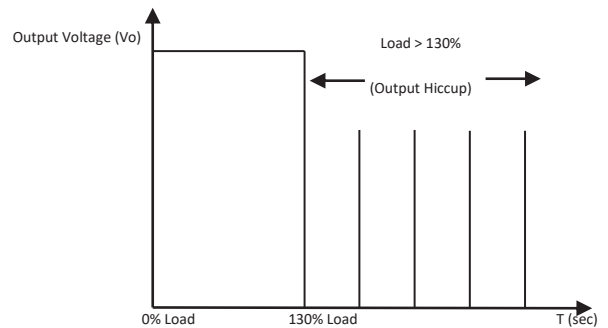

Additionally, if the I_o is $< 130\%$ but $> 110\%$ for a prolonged period of time (depending on the load), the Over Temperature Protection (OTP) will be activated due to high temperature on critical components. The power supply will then go into hiccup mode until the fault is removed; and, the input voltage is removed, then reapplied.

Over Temperature Protection

As mentioned above, the power supply also has Over Temperature Protection (OTP). This is activated when the overload condition persists for an extended duration and the output current is below the overload trigger point but $> 100\%$ load. In the event of a higher operating condition at 100% load, the power supply will run into OTP when the surrounding air temperature is higher than the operating temperature. When activated, the output voltage will go into hiccup mode until the input voltage is removed; then, reapplied, and the surrounding air temperature drops to its normal operating temperature.

Certificate



Delta has been certified as meeting the requirement of ISO 13485: 2003 and EN ISO 13485:2012 for the design and manufacture of switching power supply and adaptor for medical device.



Delta is approved for the UL Total Certification Program (TCP) approved client laboratory for IEC 62368-1. Delta also has participated UL Client Test Data Program (CTDP) for IEC 60601.



Meet Level VI Efficiency Requirement

(November 2023, Rev. 11)